



---

## Solstice AdminSuite 2.3 Administration Guide

---

Sun Microsystems, Inc.  
910 San Antonio Road  
Palo Alto, CA 94303-4900  
U.S.A.

Part No: 805-3026  
March 1998

Copyright 1998 Sun Microsystems, Inc. 901 San Antonio Road, Palo Alto, California 94303-4900 U.S.A. All rights reserved.

This product or document is protected by copyright and distributed under licenses restricting its use, copying, distribution, and decompilation. No part of this product or document may be reproduced in any form by any means without prior written authorization of Sun and its licensors, if any. Third-party software, including font technology, is copyrighted and licensed from Sun suppliers.

Parts of the product may be derived from Berkeley BSD systems, licensed from the University of California. UNIX is a registered trademark in the U.S. and other countries, exclusively licensed through X/Open Company, Ltd.

Sun, Sun Microsystems, the Sun logo, SunSoft, SunDocs, SunExpress, JavaStation, JumpStart, JavaOS, CacheFS, AdminSuite and AutoClient and Solaris are trademarks, registered trademarks, or service marks of Sun Microsystems, Inc. in the U.S. and other countries. All SPARC trademarks are used under license and are trademarks or registered trademarks of SPARC International, Inc. in the U.S. and other countries. Products bearing SPARC trademarks are based upon an architecture developed by Sun Microsystems, Inc.

The OPEN LOOK and Sun™ Graphical User Interface was developed by Sun Microsystems, Inc. for its users and licensees. Sun acknowledges the pioneering efforts of Xerox in researching and developing the concept of visual or graphical user interfaces for the computer industry. Sun holds a non-exclusive license from Xerox to the Xerox Graphical User Interface, which license also covers Sun's licensees who implement OPEN LOOK GUIs and otherwise comply with Sun's written license agreements.

**RESTRICTED RIGHTS:** Use, duplication, or disclosure by the U.S. Government is subject to restrictions of FAR 52.227-14(g)(2)(6/87) and FAR 52.227-19(6/87), or DFAR 252.227-7015(b)(6/95) and DFAR 227.7202-3(a).

DOCUMENTATION IS PROVIDED "AS IS" AND ALL EXPRESS OR IMPLIED CONDITIONS, REPRESENTATIONS AND WARRANTIES, INCLUDING ANY IMPLIED WARRANTY OF MERCHANTABILITY, FITNESS FOR A PARTICULAR PURPOSE OR NON-INFRINGEMENT, ARE DISCLAIMED, EXCEPT TO THE EXTENT THAT SUCH DISCLAIMERS ARE HELD TO BE LEGALLY INVALID.

Ce produit ou document est protégé par un copyright et distribué avec des licences qui en restreignent l'utilisation, la copie, la distribution, et la décompilation. Aucune partie de ce produit ou document ne peut être reproduite sous aucune forme, par quelque moyen que ce soit, sans l'autorisation préalable et écrite de Sun et de ses bailleurs de licence, s'il y en a. Le logiciel détenu par des tiers, et qui comprend la technologie relative aux polices de caractères, est protégé par un copyright et licencié par des fournisseurs de Sun.

Des parties de ce produit pourront être dérivées du système Berkeley BSD licenciés par l'Université de Californie. UNIX est une marque déposée aux Etats-Unis et dans d'autres pays et licenciée exclusivement par X/Open Company, Ltd.

Sun, Sun Microsystems, le logo Sun, SunSoft, SunDocs, SunExpress, , JavaStation, JumpStart, JavaOS, CacheFS, AdminSuite et AutoClient et Solaris sont des marques de fabrique ou des marques déposées, ou marques de service, de Sun Microsystems, Inc. aux Etats-Unis et dans d'autres pays. Toutes les marques SPARC sont utilisées sous licence et sont des marques de fabrique ou des marques déposées de SPARC International, Inc. aux Etats-Unis et dans d'autres pays. Les produits portant les marques SPARC sont basés sur une architecture développée par Sun Microsystems, Inc.

L'interface d'utilisation graphique OPEN LOOK et Sun™ a été développée par Sun Microsystems, Inc. pour ses utilisateurs et licenciés. Sun reconnaît les efforts de pionniers de Xerox pour la recherche et le développement du concept des interfaces d'utilisation visuelle ou graphique pour l'industrie de l'informatique. Sun détient une licence non exclusive de Xerox sur l'interface d'utilisation graphique Xerox, cette licence couvrant également les licenciés de Sun qui mettent en place l'interface d'utilisation graphique OPEN LOOK et qui en outre se conforment aux licences écrites de Sun.

CETTE PUBLICATION EST FOURNIE "EN L'ETAT" ET AUCUNE GARANTIE, EXPRESSE OU IMPLICITE, N'EST ACCORDEE, Y COMPRIS DES GARANTIES CONCERNANT LA VALEUR MARCHANDE, L'APTITUDE DE LA PUBLICATION A REPENDRE A UNE UTILISATION PARTICULIERE, OU LE FAIT QU'ELLE NE SOIT PAS CONTREFAISANTE DE PRODUIT DE TIERS. CE DENI DE GARANTIE NE S'APPLIQUERAIT PAS, DANS LA MESURE OU IL SERAIT TENU JURIDIQUEMENT NUL ET NON AVENU.



# Contents

---

## **About This Book**   xiii

## **Part I Solstice AdminSuite Overview**

### **1. Introduction**   3

What's New in the Solstice AdminSuite 2.3 Product   3

When to Use Solstice AdminSuite   4

Benefits of Solstice AdminSuite   5

Solstice AdminSuite Tools and Their Command-Line Equivalents   5

Starting the Solstice AdminSuite Tools   7

Requirements for Using Solstice AdminSuite Tools   8

Other Solstice AdminSuite Commands   9

### **2. Using Solstice AdminSuite in a Name Service Environment**   11

Available Name Service Environments   11

The `/etc/nsswitch.conf` File and the Solstice AdminSuite Product   12

Selecting a Name Service Environment   13

Working with the Name Services Transition Kit 1.2   14

Setting Up User Permissions to Use Solstice AdminSuite   14

    User Permissions in the NIS+ Environment   14

    User Permissions in the NIS Environment   15

Adding Users to the `sysadmin` Group   15

▼	How to Add a User to the sysadmin Group	15
<b>3.</b>	<b>Security</b>	<b>17</b>
	Security Information	17
	Security Levels	18
	Changing the Security Level	19
	Name Service Information	19
	Things to Consider When Creating a Security Policy	20
	Creating a Level 2 DES Security System	21
▼	How to Create Level 2 DES Security for Systems Using /etc Name Service	21
▼	How to Create Level 2 DES Security for Systems Using NIS Name Service	23
▼	How to Create Level 2 DES Security for Systems Using NIS+ Name Service	25
<b>4.</b>	<b>Using the Solstice Launcher</b>	<b>29</b>
	Starting the Solstice Launcher	29
	Registering Applications in the Solstice Launcher	31
▼	How to Privately Register an Application in the Solstice Launcher	31
▼	How to Remove a Privately Registered Application	32
▼	How to Locally Register an Application in the Solstice Launcher	33
▼	How to Remove a Locally Registered Application	34
▼	How to Globally Register an Application in the Solstice Launcher	35
▼	How to Remove a Globally Registered Application	36
	Customizing the Solstice Launcher	37
▼	How to Customize Application Properties in the Solstice Launcher	37
	Customizing Locally Registered Applications in the Solstice Launcher	39
▼	How to Modify Properties of a Locally Registered Application	39
▼	How to Use the File Selection Window	40
	<b>Part II Using Solstice AdminSuite Tools</b>	
<b>5.</b>	<b>Solstice AdminSuite Tools Reference Information</b>	<b>45</b>
	Main Window Areas	45

Using Admin Help	46
Filtering System Entries With User Manager and Group Manager	48
Filtering System Entries With Host Manager	49
Buttons	50
Global Browsing Capabilities With Host Manager	51
Batching Operations With Host Manager	52
Status Area Within Host Manager	53
Logging Solstice AdminSuite Operations	54
▼ How to Enable Logging of Solstice AdminSuite Operations	54
Using the Policy_Defaults File	55
Example of a Policy_Defaults File	57
Using Scripts With User Manager or Host Manager	58
Script Directory	58
Script Environment Variables	59
Default Scripts	59
<b>6. Managing Server and Client Support With Host Manager</b>	<b>61</b>
What Are Servers and Clients	62
What Does Support Mean	62
Overview of System Types	62
Servers	64
Standalone Systems	64
Diskless Clients	65
JavaStation Client	65
Dataless Clients	65
AutoClient Systems	65
What You Can Do With Host Manager	66
Add and Modify System Support	66
Update System Types	67

Convert System Types	68
Add OS Services	68
Remove OS Services	69
Set Up Remote Installation Services	70
Queue Tasks	70
Set Root Passwords	70
Enable Scripts	70
Add a Multihomed Host	71
What You Can't Do With Host Manager	71
Running Host Manager as Root	72
Command-Line Equivalents of Host Manager	72
Files Modified by Host Manager	73
Setting Up a Name Service Policy	74
The <code>admtb1loc</code> Command	75
Adding Server and Client Support	79
▼ How to Start Host Manager	81
▼ How to Update System Types	83
▼ How to Set Defaults for Adding Support	83
▼ How to Add Support for a Standalone System or OS Server	83
▼ How to Convert a System to an OS Server	88
▼ How to Add SunOS 4.x OS Services to an OS Server	90
▼ How to Add Solaris 2.x OS Services to an OS Server	95
▼ How to Add JavaOS Services to an OS Server	97
▼ How to Remove OS Services from an OS Server	98
▼ How to Add Support for a Diskless Client	100
▼ How to Add Support for a JavaStation Client	103
▼ How to Add Support for a Dataless Client	105
▼ How to Add a Multihomed Host	109

	Maintaining Server and Client Support	110
	▼ How to Modify Support for a System	111
	▼ How to Delete Support for a System	111
	Using the Command-Line Equivalents to Automate Setup Tasks	112
	Command-Line Equivalent Automation Example	112
<b>7.</b>	<b>Managing Users With User Manager and Group Manager</b>	<b>115</b>
	Command-Line Equivalents of Group Manager	116
	Files Modified by Group Manager	116
	Command-Line Equivalents of User Manager	117
	Files Modified by User Manager	117
	Setting Up User Accounts	118
	▼ How to Start Group Manager	119
	▼ How to Add a Group	120
	▼ How to Start User Manager	122
	▼ How to Set Up User Account Defaults	123
	▼ How to Add a New User Account	124
	▼ How to Copy an Existing User Account	127
	Maintaining User Accounts	128
	▼ How to Modify a Group	129
	▼ How to Delete a Group	131
	▼ How to Modify a User Account	131
	▼ How to Delete a User Account	133
<b>8.</b>	<b>Managing Terminals and Modems With Serial Port Manager</b>	<b>137</b>
	Serial Port Manager Features	138
	Command-Line Equivalents of Serial Port Manager	141
	Files Modified by Serial Port Manager	142
	Using Serial Port Manager	142
	▼ How to Start Serial Port Manager	142

- ▼ How to Configure Multiple Ports Using Serial Port Manager 143
- ▼ How to Add a Terminal 143
- ▼ How to Add a Modem 144
- ▼ How to Configure a Modem for Use With UUCP 146
- ▼ How to Initialize a Port Without Configuring 147
- ▼ How to Disable a Port 148
- ▼ How to Delete a Port Service 148
- 9. Setting Up SunSoft Print Client Software With Printer Manager 151**
  - Files Modified by Printer Manager 152
  - Setting Up and Managing SunSoft Print Client Software 153
  - Starting Printer Manager 154
    - ▼ How to Start Printer Manager 154
  - Installing a Printer 156
    - ▼ How to Install a Printer 156
  - Installing Network Printers 158
    - ▼ How to Install a Network Printer 158
  - Adding Access to a Printer 160
    - ▼ How to Add Access to a Printer 161
  - Modifying Printer Information 163
    - ▼ How to Modify Printer Information 163
  - Deleting Access to a Printer 165
    - ▼ How to Delete Access to a Printer 165
    - ▼ How to Delete a Printer From a Print Server (If No Name Service) 166
  - Where to Go From Here 167
- 10. Managing Network Service Files With Database Manager 169**
  - Overview of Database Manager 169
  - Files Modified by Database Manager 170
  - Managing Network Services Files 171



- ▼ How to Start Database Manager 171
- ▼ How to Add a System File Entry 172
- ▼ How to Modify a System File Entry 173
- ▼ How to Delete a System File Entry 174
- 11. Managing Disks and File Systems With Storage Manager 177**
  - Storage Manager's Load Context Property Book 178
    - ▼ How to Load an Initial Context 180
    - ▼ How to Load a Different Context 180
  - File System Manager Overview 182
  - File System Manager's Main Window 182
  - File System Manager Property Book 184
  - Managing File Systems, Mount Points, and Directories With File System Manager 186
    - ▼ How to Create a UFS File System 187
    - ▼ How to Create a Mount Point 188
    - ▼ How to Modify the Properties of a Mount Point or Directory 190
    - ▼ How to Mount or Unmount a File System 191
    - ▼ How to Share or Unshare a Directory 193
    - ▼ How to View Static Client File Systems 194
    - ▼ How to View Active Server File Systems 196
    - ▼ How to View Static Server File Systems 197
    - ▼ How to Remove a Mount Point From the `/etc/vfstab` File 198
  - Disk Manager Overview 200
  - Disk Manager's Main Window 200
    - Selecting Multiple Disks 202
  - Disk Manager Property Book 202
  - Managing Disks With Disk Manager 204
    - ▼ How to Specify a Viewing Filter 205

- ▼ How to Specify a Volume Label 206
- ▼ How to Modify `fdisk` Partitions 207
- ▼ How to Modify Slice Geometry 208
- ▼ How to Clone a Disk 209

### **Part III Additional Solstice AdminSuite Administration**

## **12. Booting a System From the Network 213**

SPARC: Booting From the Network 213

- ▼ SPARC: How to Manually Boot a System From the Network 215
- ▼ SPARC: How to Manually Boot a Sun-4 System From the Network 216
- ▼ SPARC: How to Set Up a System to Automatically Boot From the Network 217
- ▼ SPARC: How to Display Existing Boot Device Values on Sun-4 Systems 218
- ▼ SPARC: How to Set Up a Sun-4/3nn System to Automatically Boot From the Network 219
- ▼ SPARC: How to Set Up a Sun-4/1nn, 2nn, or 4nn System to Automatically Boot From the Network 220

x86: Booting From the Network 221

- ▼ x86: How to Manually Boot a System 222
- ▼ x86: How to Set Up a System to Automatically Boot From the Network 223

## **13. Monitoring Software Usage 225**

What Is Software Usage Monitoring 226

What Can Software Usage Monitoring Do 226

How Can Software Usage Monitoring Be Used 227

How Software Usage Monitoring Works 228

    Software Usage Monitoring in a Client/Server Environment 228

    Software Usage Monitoring in a Shared File System Environment 230

Before Using Software Usage Monitoring 231

- ▼ How to Verify Software Usage Monitoring Has Been Installed on a Software Usage Monitoring Server 231

- ▼ How to Verify That Software Usage Monitoring Is Installed and Enabled on a Client 232
- ▼ How to Verify that Software Usage Monitoring is Enabled on a Host in a Shared File System Environment 233
- Starting and Stopping the `swu_svr` Daemon 233
  - ▼ How to Start the `swu_svr` Daemon 233
  - ▼ How to Stop the `swu_svr` Daemon 234
- Generating Software Usage Report Entries 234
  - Using a Command-Line Interface 234
  - ▼ How to Monitor Software Usage Using a Command-Line Interface 235
    - Using Shell Scripts 237
  - ▼ How to Monitor Software Usage Using a Shell Script Wrapper 238
  - ▼ How to Add Software Usage Monitoring to a Shell Script Program Executable Command Line 240
    - Using an Embedded Application 242
  - ▼ How to Embed Software Usage Monitoring into Applications 242
- Transferring Software Usage Entries on a Client to the Master Log File on the Software Usage Monitoring Server 245
  - ▼ How to Transfer Software Usage Entries on the Client to the Master Log File on the Software Usage Monitoring Server 247
- Printing Software Usage Data from the Master Log File 247
  - ▼ How to Print Software Usage Data from the Master Log File 250
- Removing the Master Log File 251
  - ▼ How to Remove the Master Log File 251
- Glossary 253**
- Index 263**



# About This Book

---

The *Solstice AdminSuite 2.3 Administration Guide* provides product overview, task, and reference information for Solstice™ AdminSuite™ 2.3, a suite of graphical user interface tools used to perform system administration tasks in the Solaris™ software environment.

---

## Who Should Use This Book

This book is intended for anyone responsible for using the Solstice AdminSuite software to perform administrative tasks such as setting up and modifying users, groups, servers, printers, clients, modems, or terminals.

This book assumes that you are familiar with the mouse-use terminology such as Select (click on an item once) and Choose (click on a menu button and slide the cursor to the item you would like to choose).

---

## Before You Use This Product

To use this product, you should be familiar with UNIX® system software concepts, the network configuration of your site, and your site policies for security.

---

# How This Book Is Organized

This book has three parts:

- Part 1 – Provides overview information on the Solstice AdminSuite software.
- Part 2 – Provides task-specific information needed to use the Solstice AdminSuite software.
- Part 3 – Provides information on additional administration that you may need to do after using the Solstice AdminSuite software, and additional administration that the Solstice AdminSuite software provides.

---

# What Typographic Changes Mean

The following table describes the typographic changes used in this book.

TABLE P-1 Typographic Conventions

Typeface or Symbol	Meaning	Example
AaBbCc123	The names of commands, files, and directories; on-screen computer output	Edit your <code>.login</code> file. Use <code>ls -a</code> to list all files. <code>machine_name% You have mail.</code>
<b>AaBbCc123</b>	What you type, contrasted with on-screen computer output	<code>machine_name%su</code> <code>Password:</code>
<i>AaBbCc123</i>	Command-line placeholder: replace with a real name or value	To delete a file, type <code>rm filename</code> .
<b><i>AaBbCc123</i></b>	Book titles, new words or terms, or words to be emphasized	Read Chapter 6 in <i>User's Guide</i> . These are called <i>class</i> options. You <i>must</i> be root to do this

---

# Shell Prompts in Command Examples

The following table shows the default system prompt and root prompt for the C shell, Bourne shell, and Korn shell.

TABLE P-2 Shell Prompts

Shell	Prompt
C shell prompt	machine_name%
C shell superuser prompt	machine_name#
Bourne shell and Korn shell prompt	\$
Bourne shell and Korn shell superuser prompt	#





This part provides an overview of the Solstice AdminSuite software and contains these chapters.

**Chapter 1**

*Introduction* provides brief descriptions of all the software included with the Solstice AdminSuite product.

**Chapter 2**

*Using solstice AdminSuite in a Name Service Environment* provides information on how to use the Solstice AdminSuite software in a name service environment.

**Chapter 3**

*Security* describes security issues and provides suggestions on how to use the Solstice AdminSuite software in a manner that conforms to your site security policies.

**Chapter 4**

*Using the Solstice Launcher* provides instructions on how to start the Solstice Launcher and add applications to the Solstice Launcher.



## Introduction

---

Solstice AdminSuite is a collection of graphical user interface tools and commands used to perform administrative tasks such as managing users, groups, hosts, system files, printers, disks, file systems, terminals, and modems.

This is a list of the overview information in this chapter.

- “What’s New in the Solstice AdminSuite 2.3 Product” on page 3
- “When to Use Solstice AdminSuite” on page 4
- “When to Use Solstice AdminSuite” on page 4
- “Benefits of Solstice AdminSuite” on page 5
- “Solstice AdminSuite Tools and Their Command-Line Equivalents” on page 5
- “Other Solstice AdminSuite Commands” on page 9

---

## What’s New in the Solstice AdminSuite 2.3 Product

The Solstice AdminSuite 2.3 product provides the following new features:

- Printer Manager network printer functionality  
Printer Manager now has the ability to add a printer to your network. For more information about Printer Manager, see its online help and Chapter 9.
- Password capability  
Using Group Manager, you can set group or database passwords. In addition, you can set the system’s root password using Host Manager.
- Multihomed host alias support

Host Manager now enables you to add additional IP addresses for hosts that have multiple network interfaces. Refer to Chapter 6 for more information about creating multihomed hosts.

- JavaStation™ support

To accommodate JavaStation clients, Host Manager now enables you to add JavaStations to your network. Refer to Chapter 6 for more information.

- OS services removal support

Host Manager now allows you to remove OS services from an OS server. Refer to Chapter 6 for more information.

- High Sierra File Systems support

Storage Manager supports the creation of a High Sierra file system mount point. Refer to Chapter 11 for more information.

- Script enabler support

The Host Manager and User Manager tools have been updated with the ability to run scripts that you have created to customize your operations. For example, you may have scripts that you run when you add a user to your system. Using the script feature, you can add a user from User Manager and also run the script at the same time by using the Scripts Enabled feature.

- CacheFS™ boot for Solaris 2.6-based AutoClients

A new booting process for Solaris 2.6-based AutoClients creates a cache during the initial boot. Refer to *Solstice AutoClient 2.1 Administration Guide* for more information about the CacheFS boot process.

---

**Note** - The Solstice AutoClient 2.1 product is part of the Solstice AdminSuite 2.3 product. Even though Host Manager has the ability to add AutoClient systems, you should first obtain an AutoClient license to add and run an AutoClient system.

---

- Updated root user handling

Previous versions of AdminSuite had limited root capabilities; that is, when running AdminSuite as root, very few functions could be performed. AdminSuite 2.3 has been updated to allow root more flexibility in running AdminSuite applications.

---

## When to Use Solstice AdminSuite

The Solstice AdminSuite software enables you to locally or remotely manage:

- Important system database files, such as `aliases` and `hosts`

- User accounts and groups
- File systems
- Disk slices and `fdisk` partitions
- Terminals and modems
- Diskless and dataless clients
- AutoClient systems
- Standalone systems
- JavaStations
- Servers
- Printers

See Chapter 2, for information on controlling access to the Solstice AdminSuite software.

---

## Benefits of Solstice AdminSuite

Using the Solstice AdminSuite software to perform system administration tasks has these benefits:

- The tools and commands are faster than using numerous Solaris commands to perform the same tasks.
- System files are updated automatically without the risk of making errors by editing important system files manually.
- You can manage systems remotely from one system.

---

## Solstice AdminSuite Tools and Their Command-Line Equivalents

Table 1-1 lists the Solstice AdminSuite tools that must be run under an X Window System™, such as the OpenWindows™ environment. Table 1-1 also lists the commands that provide the same functionality as the Solstice AdminSuite tools and can be used without running an X Window System. The chapters in Part 2 for each tool provide corresponding examples for the AdminSuite command-line equivalents in each procedure.

---

**Note** - The command-line equivalents are available only after AdminSuite has been installed.

---

**TABLE 1-1** Solstice AdminSuite Tools and Their Command-Line Equivalents

<b>AdminSuite Tool</b>	<b>AdminSuite Command-Line Equivalents</b>	<b>Helps You Manage ...</b>	<b>Described In ...</b>
Host Manager	admhostadd.1m	System information and server support for AutoClient and standalone systems, diskless and dataless clients, and JavaStations	Chapter 6
	admhostdel.1m		
	admhostmod.1m		
	admhostls.1m		
Group Manager	admgroupadd.1m	UNIX group information	Chapter 7
	admgroupdel.1m		
	admgroupmod.1m		
	admgrouppls.1m		
User Manager	admuseradd.1m	User account information	Chapter 7
	admuserdel.1m		
	admusermod.1m		
	admuserls.1m		
Serial Port Manager	admserialdel.1m	Serial port software for terminals and modems	Chapter 8
	admserialmod.1m		
	admserialls.1m		
Printer Manager	- none -	Printer software for print servers and clients	Chapter 9

TABLE 1-1 Solstice AdminSuite Tools and Their Command-Line Equivalents *(continued)*

AdminSuite Tool	AdminSuite Command-Line Equivalents	Helps You Manage ...	Described In ...
Database Manager	- none -	Network-related system files such as aliases and hosts	Chapter 10
Storage Manager (consists of Disk Manager and File System Manager)	- none -	Disk slices and fdisk partitions on a single disk or a group of equivalent disks (Disk Manager) and file systems for a server or for a group of clients on a server (File System Manager)	Chapter 11

## Starting the Solstice AdminSuite Tools

The Solstice Launcher must be used to start the Solstice AdminSuite tools. Enter the following command to start the Solstice Launcher, which must be run on an X Window System:

```
$ solstice &
```

The Solstice Launcher is displayed.

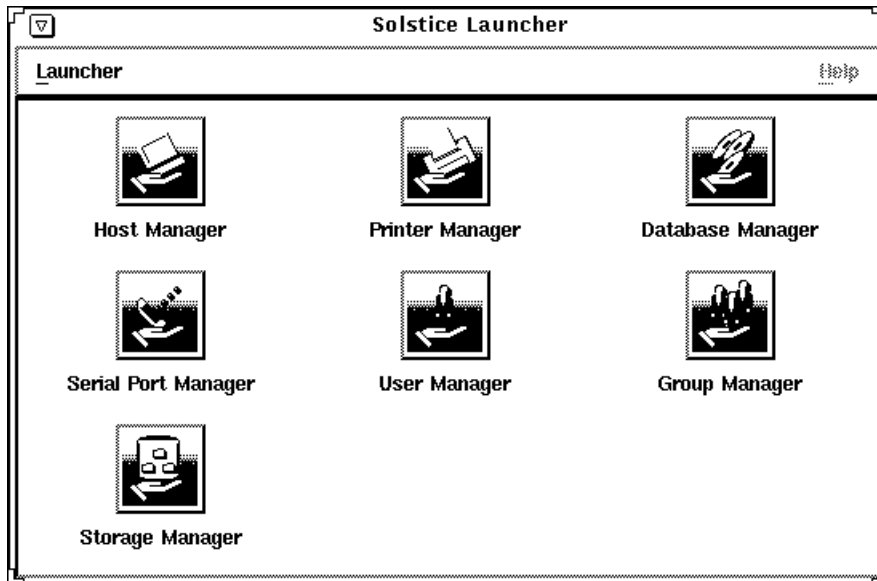

---

**Note** - You can also start the Solstice Launcher by using the `-display` option to display on a big-mapped remote host running the X Window system.

---

From the Solstice Launcher, you can:

- Click on an icon in the Launcher to start a tool.  
You can also use the Tab key to move from icon to icon, and press the Space bar to start a tool.
- Close the Launcher (and each tool) to an icon by clicking on the Window menu in the top left corner of each tool's main window.

See Chapter 4, for more information about using the Launcher.

---

## Requirements for Using Solstice AdminSuite Tools

To use the Solstice AdminSuite tools, you must have:

- A bit-mapped display monitor. The Solstice AdminSuite tools can be used only on a system where the console is a bit-mapped screen such as a standard display monitor that comes with a Sun<sup>®</sup> workstation.

If you want to perform administration tasks on a system with an ASCII terminal as the console, use the command-line equivalents of the Solstice AdminSuite tools.



- X Window System software, such as the OpenWindows environment.
- Root privilege or membership in the sysadmin group (group 14) and the required access privileges for managing the NIS or NIS+ database. See Chapter 2, for more information.

---

**Note** - AdminSuite has some limitations as to what you can or can not do as root; you should use the Solstice AdminSuite tools as a regular user who has membership in the sysadmin group (group 14) rather than as root.

---

## Other Solstice AdminSuite Commands

TABLE 1-2 Solstice AdminSuite Commands

Command	Enables You To ...	Described In ...
<code>admclientpatch(1m)</code>	Provide a centralized way to add patches to AutoClient systems and diskless clients. Host Manager then automatically adds the patches when you add an AutoClient system or a diskless client.	<i>Solstice AutoClient 2.1 Administration Guide</i>
<code>admtblloc(1m)</code>	Set a customized name service policy for Host Manager.	“Setting Up a Name Service Policy” on page 74
<code>admhalt(1m)</code>	Halt one or more remote systems.	<code>admhalt(1m)</code> man page
<code>admreboot(1m)</code>	Reboot one or more remote systems.	<code>admreboot(1m)</code> man page
<code>cachefspack</code>	Provides a way to set up and maintain files in your cache; with this command, you can pack the cache on an AutoClient system.	<code>cachefspack</code> man page
<code>filesync</code>	Record the names of all the files that are to be kept in sync with the <code>filesync</code> command.	<code>filesync</code> man page



## Using Solstice AdminSuite in a Name Service Environment

---

The Solstice AdminSuite software can be used in different name service environments. When you use each application or AdminSuite command-line equivalent, you must specify the name service environment data you wish to modify.

This is a list of the overview information in this chapter.

- “Available Name Service Environments” on page 11
- “The `/etc/nsswitch.conf` File and the Solstice AdminSuite Product” on page 12
- “Selecting a Name Service Environment” on page 13
- “Working with the Name Services Transition Kit 1.2” on page 14
- “Setting Up User Permissions to Use Solstice AdminSuite” on page 14
- “Adding Users to the `sysadmin` Group” on page 15

---

### Available Name Service Environments

Solstice AdminSuite can be used to manage information on the local system or across the network using a name service. The sources of information that can be managed by Solstice AdminSuite are described in Table 2-1.

---

**Note** - When using AdminSuite with a name service, you can only modify information found in the local domain. AdminSuite does not support NIS+ or NIS subdomain modifications. If you wish to change entries in NIS or NIS+ in a subdomain, you must log in and run AdminSuite on a system within the subdomain.

---

TABLE 2-1 Available Name Service Environments

Name Service	Select This Name Service to Manage ...
NIS+	NIS+ table information. This requires sysadmin group (group 14) membership and the appropriate ownership or permissions on the NIS+ tables to be modified.
NIS	NIS map information. You must be a member of the sysadmin group. If the NIS master server is running the Solaris 1.x OS Release, you must have explicit permissions on the NIS master server to update the maps. This means an entry for your host name and user name must reside in root's <code>.rhosts</code> file on the NIS master server. This entry is not required if the NIS master server is running the Solaris 2.x OS Release and the Name Services Transition Kit 1.2 software and Solstice AdminSuite is installed.
None	The <code>/etc</code> files on the local system. You must be a member of the sysadmin group on the local system.

See "Setting Up User Permissions to Use Solstice AdminSuite" on page 14 for information on using Solstice AdminSuite with or without a name service environment.

---

## The `/etc/nsswitch.conf` File and the Solstice AdminSuite Product

The Solstice AdminSuite software allows you to select which name service databases will be updated (written to) when you make modifications with one of the tools. However, the `/etc/nsswitch.conf` file on each system specifies the policy for name service lookups (where data will be read from) on that system.



---

**Caution** - It is up to the user to make sure that the name service they select from one of the tools is consistent with the specifications in the `/etc/nsswitch.conf` file. If the selections are not consistent, the tools may behave in unexpected ways, resulting in errors or warnings. See "Selecting a Name Service Environment" on page 13 for an example of the window from which you select a name service.

---

The `/etc/nsswitch.conf` file has no effect on how the system configuration files get updated. In the `/etc/nsswitch.conf` file, more than one source can be specified for the databases, and complex rules can be used to specify how a lookup

can be performed from multiple sources. There is no defined syntax for using the rules in the `/etc/nsswitch.conf` file to perform updates.

Because of this, updates are controlled by the name service selection that is made when the tools are started. The administrator must decide where the update is to take place.

When using the tools, administrative operations can take place on multiple systems with a single operation. It is possible that each of these systems could have a different `/etc/nsswitch.conf` configuration. This situation can make it very difficult to administer your network. It is recommended that all of the systems have a consistent set of `/etc/nsswitch.conf` files and that the Solstice AdminSuite software is used to administer the primary name service specified in the standard `/etc/nsswitch.conf` file.

With this release of the Solstice AdminSuite product, you can define a more complex update policy for the tools by using the `admtblloc` command. For more information on this command, refer to the `admtblloc(1M)` man page and see “The `admtblloc` Command” on page 75.

---

## Selecting a Name Service Environment

After you start the Solstice Launcher and click on a Solstice application icon, a window is displayed prompting you to select a name service. Select the name service that is appropriate for your environment.

This example is from Host Manager’s Load window.

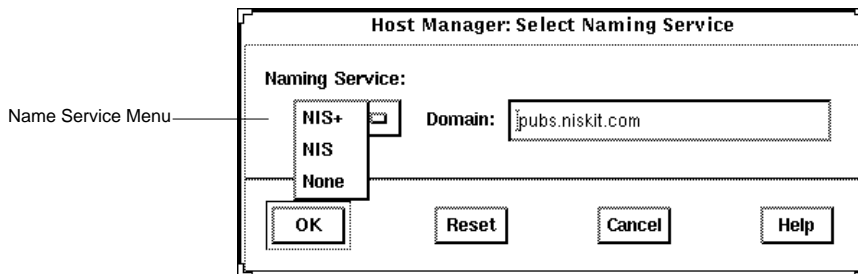

---

**Note** - The NIS and NIS+ environments are not available for Serial Port Manager.

---

---

## Working with the Name Services Transition Kit 1.2

The Name Services Transition Kit 1.2 is designed to allow you to support a NIS server running Solaris 2.x. Installing the software and setting up the Solaris 2.x NIS servers is described in the *Name Services Transition Kit 1.2 Administrator's Guide*. Solstice AdminSuite can manage information using the NIS name service supported by Solaris 2.x NIS servers installed with the Name Services Transition Kit 1.2 software.

On NIS servers installed with the Solaris 2.x OS Release, the Name Service Transition Kit 1.2, and Solstice AdminSuite, the configuration files stored in the `/etc` directory are modified by Solstice AdminSuite applications (these files are in turn automatically converted to NIS maps). If the NIS server is not installed with Solstice AdminSuite, then the directory location specified by the `$DIR` variable in the `/var/yp/Makefile` is used.

---

## Setting Up User Permissions to Use Solstice AdminSuite

To use Solstice AdminSuite, membership in the `sysadmin` group (group 14) is required. See "Adding Users to the `sysadmin` Group" on page 15 for more information.

Following are additional requirements to use Solstice AdminSuite for each name service.

### User Permissions in the NIS+ Environment

The requirements for using Solstice AdminSuite are:

- Membership in the NIS+ admin group.
- Modify permissions on the NIS+ tables to be managed. These permissions are usually given to the NIS+ admin group members.

See *Solaris Naming Administration Guide* for information on adding users to a NIS+ group and granting permissions on NIS+ tables.

# User Permissions in the NIS Environment

The requirements for using Solstice AdminSuite are:

- An entry for your host name and user name in root's `.rhosts` file on the NIS master server if the server is running the Solaris 1.x OS Release. If the NIS master server is running the Solaris 2.x OS Release and Name Services Transition Kit 1.2 software, this entry is not required as long as Solstice AdminSuite is also installed.
- Running `ybind` with the `-broadcast` option, which is the default form, if you want to manage NIS map information in domains other than your own.

---

**Note** - In order to manager NIS map information in domains other than your own, the other NIS domain masters need to be on directly attached networks.

---

---

## Adding Users to the sysadmin Group

The following procedure describes how to add users to the `sysadmin` group using Group Manager, a tool within the Solstice AdminSuite software. To use this tool, you must be already be a member of the `sysadmin` group and meet the requirements for each name service listed in “Setting Up User Permissions to Use Solstice AdminSuite” on page 14.

If you do not have access to a user account that is a member of the `sysadmin` group to run Group Manager, see the procedure to add users to the `sysadmin` group described in the *Solstice AdminSuite 2.3 Installation and Product Notes*.

### ▼ How to Add a User to the sysadmin Group

1. **Verify that the prerequisites described in “Requirements for Using Solstice AdminSuite Tools” on page 8 are met.**
2. **Type `solstice &` in a Shell or Command Tool window.**  
The Solstice Launcher is displayed.
3. **Click on the Group Manager icon.**  
The Group Manager Load window is displayed.
4. **Select the name service you wish to modify.**
5. **Click on OK.**  
The Group Manager main window is displayed.

- 6. Click on the sysadmin group in the Group Manager main window.**
- 7. Select Modify from the Edit Menu.**  
The Modify window is displayed.
- 8. Add a comma-separated list of members to the Members List text box.**  
The list must not contain spaces.
- 9. Click on OK.**



# Security

---

An important part of using the Solstice AdminSuite software is understanding its security features and setting up security policies to protect your administrative data.

This is a list of the step-by-step instructions in this chapter.

- “Security Information” on page 17
- “Things to Consider When Creating a Security Policy” on page 20
- “Creating a Level 2 DES Security System” on page 21

---

## Security Information

Solstice AdminSuite uses the distributed system administration daemon (`sadmind`) to carry out security tasks when you perform administrative tasks across the network. The `sadmind` daemon executes the request on the server on behalf of the client process and controls who can access Solstice AdminSuite.

Administering security involves *authentication* of the user and *authorization* of permissions.

- Authentication means that the `sadmind` daemon must verify the identity of the user making the request.
- Authorization means that `sadmind` verifies that the authenticated user has permission to execute Solstice AdminSuite on the server. After the user identity is verified, `sadmind` uses the user identity to perform authorization checks.

If you have permission to use Solstice AdminSuite, you also need to have create, delete, or modify permission before you can change an NIS+ map. See *NIS+ and DNS Setup and Configuration Guide* for a description of NIS+ security.

User and group identities are used for authorization checking as follows:

- Root identity – The root identity has privileges (to access and update data) only on the local system. If the server is the local system (in other words, if the user has logged in as root on the server), the user will be allowed to perform Solstice AdminSuite functions on the server under the root identity.
- User who is a member of sysadmin group (group 14) – Solstice AdminSuite permissions are granted to users who are members of the sysadmin group (group 14). This means that a user modifying administration data must be a member of the sysadmin group on the system where the task is being executed.

## Security Levels

Each request to change administration data contains a set of credentials with a UID and a set of GIDs to which the user belongs. The server uses these credentials to perform identity and permission checks. Three levels of authentication security are available.

The security levels are described in Table 3-1.

TABLE 3-1 Solstice AdminSuite Security Levels

Level	Level Name	Description
0	NONE	No identity checking is done by the server. All UIDs are set to the <code>nobody</code> identity. This level is used mostly for testing.
1	SYS	The server accepts the original user and group identities from the client system and uses them as the identities for the authorization checks. There is no checking to be sure that the UID of the user represents the same user on the server system. That is, it is assumed the administrator has made the UIDs and GIDs consistent on all systems in the network. Checks are made to see if the user has permission to execute the request.
2	DES	Credentials are validated using DES authentication, and checks are made to be sure that the user has permission to execute the request. The user and group identities are obtained from files on the server system by mapping the user's DES network identity to a local UID and set of GIDs. The file used depends on which name service is selected on the server system. This level provides the most secure environment for performing administrative tasks and requires that a <code>publickey</code> entry exists for all server systems where the <code>sadmind</code> daemon is running, and for all users accessing the tools.

---

**Note** - Level 1 is the default security used by `sadmind`.

---

## Changing the Security Level

You can change the security level from Level 1 to Level 2 by editing the `/etc/inetd.conf` file on each system, and adding the `--S 2` option to the `sadmind` entry. If you do this, make sure that the servers in the domain are set up to use DES security.

You do not need to maintain the same level of security on all systems in the network. You can run some systems, such as file servers requiring strict security, at security Level 2, while running other systems at the default Level 1 security.

See the description of how to set up security for NIS+ in *NIS+ and FNS Administration Guide*.

## Name Service Information

The `sadmind` daemon uses information held by the name service. The three sources of information are:

- Files in the `/etc` directory such as `passwd`, `group`, and `shadow`, referred to as the **keyword files**
- The NIS name service referred to as the keyword `nis`
- The NIS+ name service referred to as the keyword `nisplus`

On each system, the `/etc/nsswitch.conf` file lists several administrative files, followed by a list of one or more keywords that represent the name services to be searched for information. If more than one keyword is listed, they are searched in the order given. For example, the entry

```
group: files nisplus
```

indicates that the security mechanism looks first in the local `/etc/group` file for an entry. If the entry exists, the security mechanism uses the information in this entry. If the entry doesn't exist, the NIS+ `group` file is searched.

By default, systems running the Solaris 2.4 and higher OS release have an entry for `group 14` in the local `/etc/group` file. If you want to set up your system to use network-wide information, do not add members to the `sysadmin` group on the local system. Instead, update the `group14` entry found in the group table stored in the name service.

When running under Level 2 security, the security mechanisms use the `public/private` key information. Make sure that the entry for `publickey` is followed by either `nis` or `nisplus` (depending on which name service you are using), and remove the `files` designation. See *NIS+ and FNS Administration Guide* for more information about the `nsswitch.conf` file.

---

# Things to Consider When Creating a Security Policy

Consider the following when creating a security policy for using Solstice AdminSuite in a name service environment.

- Determine how much trust is needed.

If your network is secure and you do not need to use authentication security, you can use Solstice AdminSuite applications with the default Level 1 security.

If you need to enforce a higher level of security, you can set the security level of `sadmin` to Level 2.

- Determine which name service will be used.

The name service determines where the security methods get information about user and group identities. The name services are designated in the `/etc/nsswitch.conf` file (see “Name Service Information” on page 19).

- Decide which users have access to Solstice AdminSuite.

Decide which users will perform administrative functions over the network with Solstice AdminSuite. List these users as members of group 14 accessed by the server system. The group 14 must be accessible from each system where administration data will be updated by Solstice AdminSuite. The group 14 can be established locally on each system or can be used globally within a name service domain, depending upon the policy established by the administrator.

- Determine global and local policies.

The *global policy* affects all hosts in the network. For example, you can add members to group 14 in the NIS or NIS+ `group` file. Members of this group will have permission to perform administrative tasks on all server systems that list the network name service as the primary source of information. The name services are listed in the `/etc/nsswitch.conf` file. For more information about the `nsswitch.conf` file, see “Name Service Information” on page 19.

A user can establish a local policy that is different from the global policy by creating a group 14 in the local `/etc/group` file and listing the users who have access to the local system. The members of this group will have permission to manipulate or run Solstice AdminSuite methods on the user’s local system.

---

**Note** - Setting up a local policy does not disable a global policy. Name service access is determined by the `nsswitch.conf` file.

---

- Set up permissions for NIS+ management.

You need the proper permissions when using Solstice AdminSuite to modify or update the NIS+ files. In addition to the permissions required by Solstice

AdminSuite, the NIS+ security mechanisms impose their own set of access permissions. The NIS+ security mechanisms are described in *NIS+ and FNS Administration Guide*.

- Set up access for NIS management.

If the NIS master server is running the Solaris 1.x operating system, a user must have a `.rhosts` entry on the NIS master server to modify the NIS files. If the NIS master server is running the Solaris 2.x operating system and the Name Services Transition Kit 1.2, then no entry is required if AdminSuite is already installed. The NIS updates will be authorized using the standard group 14 mechanism.

---

## Creating a Level 2 DES Security System

Creating a Level 2 DES security system requires a number of steps that depend upon your system configuration. The following sections describe how to set up your system to have level 2 DES security for systems using `/etc`, NIS, and NIS+ name services.

### ▼ How to Create Level 2 DES Security for Systems Using `/etc` Name Service

1. **On each system that runs the `sadmind` daemon, edit the `/etc/inetd.conf` file.**

Change this line (or one similar to this):

```
100232/10 tli rpc/udp wait root /usr/sbin/sadmind sadmind
```

to:

```
100232/10 tli rpc/udp wait root /usr/sbin/sadmind sadmind -s 2
```

2. **On each system that runs the `sadmind` daemon, set the `/etc/nsswitch.conf` entry for `publickey` to `files`.**

Change this entry (or one similar to this):

```
publickey: nis [NOTFOUND=return] files
```

to:

```
publickey: files
```

**3. Create credentials for all group 14 users and all of the systems that will run**

`sadmind -S 2.`

**a. Log in as root to one of the systems that will run** `sadmin -S 2.`

**b. Run the following command for each user that will run AdminSuite.**

```
# newkey -u username
```

---

**Note** - You must run this command even for users who are not in group 14. If you are not in group 14 and do not have credentials, you are not a user according to `sadmind`; you will not be able to run any methods, even those that do not require root. You will have to supply the user's password to the `newkey` program.

---

**c. Run the following command for every host that you have configured to run secure** `sadmind`.

```
# newkey -h hostname
```

You will have to provide the root password for each of these hosts to the `newkey` program.

**d. Copy the `/etc/publickey` file on this system to each of the hosts (put this file in `/etc/publickey`).**

This file contains all the credentials for each user and each host.

---

**Note** - Do not run `newkey` on each of the systems. This seems to create a different `public/private` key pair, and the public key will not be valid across the network. You must create this file on one machine and then copy it to all the others.

---

**e. As root, enter the following command on each system to put root's private key in `/etc/.rootkey`.**

```
# keylogin -r
```

By doing this, you will not have to `keylogin` as root on every system every time you want to run `admintool`; this creates an automatic root `keylogin` at boot time.

4. **Create an `/etc/netid` file for each user and each system; put this file on all of the systems.**
  - a. **For each user in the `publickey` file, create an entry in `/etc/netid` that looks like the following:**

```
unix.uid@domainname uid: uid: gid, gid, ...
```

- b. **List every group that this user is a member of; `sadmind -S 2` and files look to `netid` rather than `/etc/group` to determine group 14 membership.**
  - c. **For each host in the `publickey` file, create an entry in `/etc/netid` that looks like the following:**

```
unix.hostname@domainname 0:hostname
```

- d. **Copy this file to every system in `/etc/netid`.**

5. **Reboot all of the machines.**

6. **On each system that you want to run the application on, log in and then `keylogin`. (You must be a member of group 14.)**

After the `keylogin`, you can safely log out; your key is stored in the `keyserv` daemon until you explicitly `keylogout` or the system reboots.

## ▼ How to Create Level 2 DES Security for Systems Using NIS Name Service

1. **On each system that runs the `sadmind` daemon, edit the `/etc/inetd.conf` file.**

Change this line (or one similar to this):

```
100232/10 tli rpc/udp wait root /usr/sbin/sadmind admind
```

to:

```
100232/10 tli rpc/udp wait root /usr/sbin/sadmind admind -S 2
```

2. **On each system that runs the `sadmind` daemon, set the `/etc/nsswitch.conf` entry for `publickey` to `nis`.**

Change this entry (or one similar to this):

```
publickey: nis [NOTFOUND=return] files
```

to:

```
publickey: nis
```

3. **Create credentials for all group 14 users and all of the systems that will run `sadmind -S 2`.**

- a. **Log in as root on the NIS server.**

- b. **Run the following command for each user that will run AdminSuite.**

```
# newkey -u username -s files
```

---

**Note** - You must run this command even for users who are not in group 14. If you are not in group 14 and do not have credentials, you are not a user according to `sadmind`; you will not be able to run any methods, even those that do not require root. You will have to supply the user's password to the `newkey` program.

---

- c. **Run the following command for every host that you have configured to run `secure sadmind`.**

```
# newkey -h hostname
```

You will have to provide the root password for each of these hosts to the `newkey` program.

- d. **Copy the `/etc/publickey` file on this system to the source file that is specified in `/var/yp/Makefile`; remake and push the `nis` maps.**

```
# cd /var/yp; make
```

4. **Verify that you are a member of group 14 in the `group/nis` maps.**
  - a. **Login as root.**



- b. Change directories to the source file specified in `/var/yp/Makefile`.
- c. Manually edit the group file and add yourself to group 14, just as you did in the `/etc/group` file.
- d. Change directories to `/var/yp` and run `make`.

```
# cd /var/yp; make
```

You should see the group map pushed; a message appears indicating that this action has occurred.

---

**Note** - The security system looks in the NIS maps for your group 14 access and will fail if you do not have `group14` specified there, regardless if your `/etc/nsswitch.conf` file has group files `nis`.

---

When `sadmind` is running in `-S 2` mode, it uses the `publickey` entry to determine which name service to look at for user credentials. When the entry in `/etc/nsswitch.conf` is `nis`, it looks in the `nis` group map to ensure that the user is a member of group 14.

5. As root, enter the following command on each system to put root's private key in `/etc/.rootkey`.

```
# keylogin -r
```

By doing this, you will not have to `keylogin` as root on every system every time you want to run AdminSuite; this creates an automatic root `keylogin` at boot time.

6. To ensure that the `nscd` gets flushed, reboot all of the workstations.
7. On each system that you want the application to run on, log in and then `keylogin`. (You must be a member of group 14.)  
After the `keylogin`, you can safely log out; your key is stored in the `keyserv` daemon until you explicitly `keylogout` or the system reboots.

## ▼ How to Create Level 2 DES Security for Systems Using NIS+ Name Service

1. On each system that runs the `sadmind` daemon, edit the `/etc/inetd.conf` file.

Change this line:

```
100232/10 tli rpc/udp wait root /usr/sbin/sadmind sadmind
```

to:

```
100232/10 tli rpc/udp wait root /usr/sbin/sadmind sadmind -s 2
```

- 2. On each system that runs the `sadmind` daemon, set the `/etc/nsswitch.conf` entry for `publickey` to `nisplus`.**

Change this entry (or one similar to this):

```
publickey: nisplus [NOTFOUND=return] files
```

to:

```
publickey: nisplus
```

- 3. Log in as root on the NIS+ master server; create credentials for all group 14 users and all of the systems that will run `sadmind -S 2`.**

**a. Create local credentials for the user.**

```
# nisaddcred -p uid username.domainname. local
```

**b. Create des credentials for the user.**

```
# nisaddcred -p unix.uid@domainname -P username.domainname. des
```

- 4. Log in as root on the NIS+ master server; add all of the users for the AdminSuite to the NIS+ group 14 using the following command.**

```
# nistbladm -m members=username,username...[name=sysadmin],group.org_dir
```

---

**Note** - The use of this function replaces the current member list with the one that is input; therefore, you must include all members you wish to be a part of group 14.

---

- 5. As root, add all of the users for the AdminSuite to the NIS+ admin group.**

```
# nisgrpadm -a admin username
```

Verify that the `NIS_GROUP` environmental variable is set to `admin`.

- 6. On all the workstations that you intend to run the `admintool`, enter the following command.**

```
# keylogin -r
```

- 7. Reboot all of the workstations; verify that the `nscd` gets flushed.**
- 8. On each system that you want the application to run on, log in and then `keylogin`. (You must be a member of group 14.)**  
After the `keylogin`, you can safely log out; your key is stored in the `keyserv` daemon until you explicitly `keylogout` or the system reboots.



---

## Using the Solstice Launcher

---

The Solstice Launcher provides access to the Solstice product family of administration tools. The tools that appear in the Launcher depend on what Solstice products you have installed on your system.

This is a list of the topics and step-by-step instructions in this chapter.

- “Starting the Solstice Launcher” on page 29
- “How to Privately Register an Application in the Solstice Launcher” on page 31
- “How to Remove a Privately Registered Application” on page 32
- “How to Locally Register an Application in the Solstice Launcher” on page 33
- “How to Remove a Locally Registered Application” on page 34
- “How to Globally Register an Application in the Solstice Launcher” on page 35
- “How to Remove a Globally Registered Application” on page 36
- “How to Customize Application Properties in the Solstice Launcher” on page 37
- “How to Modify Properties of a Locally Registered Application” on page 39
- “How to Use the File Selection Window” on page 40

---

### Starting the Solstice Launcher

Start the Solstice Launcher from a window as follows:

```
$ solstice &
```

The Solstice Launcher is displayed.

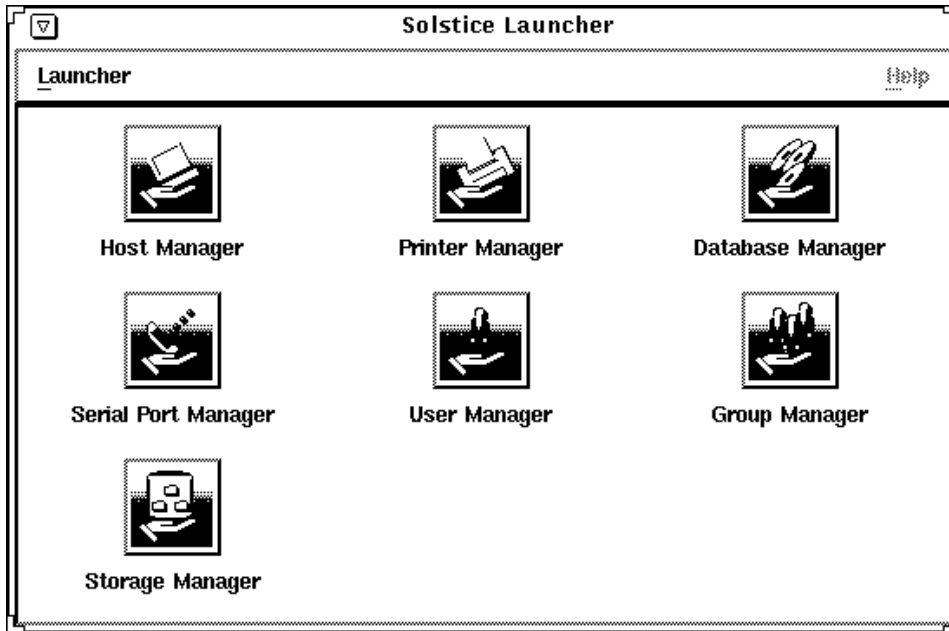

The Solstice Launcher menus are described in Table 4-1.

TABLE 4-1 Solstice Launcher Menus

Use This Menu ...	To Access This Command ...	That Performs This Function ...
Launcher	Add Application	Adds and registers applications with the Launcher.
	Properties	Provides ability to customize the launcher by showing, hiding, or removing applications; reordering the icons; changing the Launcher window width; modifying application properties; adding applications.
	Exit	Stops running the Solstice Launcher. Does not affect open or iconified applications.

---

# Registering Applications in the Solstice Launcher

Applications that display in the Solstice Launcher are registered. This means that you can add and remove applications, including custom applications, to and from the Launcher main window.

Applications are registered in three ways:

- **Private registry** – Registered applications are private to the user. Applications are registered privately with the Add Application command from the Launcher menu. See “How to Privately Register an Application in the Solstice Launcher” on page 31 for instructions on registering applications privately.

Privately registered applications can be added, removed, and their properties can be modified from the Solstice Launcher.

- **Local registry** – Registered applications are local to the system. Applications registered locally are available to all local users of the system. Applications can only be registered locally with the `/usr/snadm/bin/soladdapp` command. See “How to Locally Register an Application in the Solstice Launcher” on page 33 for information on using the `soladdapp` command to register applications locally.

Locally registered applications can only be added or removed using the `soladdapp` and `soldelapp` commands. Their properties cannot be modified from the Solstice Launcher.

- **Global registry** – Registered applications are shared by all local and remote users using the Solstice Launcher in a particular `/opt` directory. Applications can only be registered globally with the `/usr/snadm/bin/soladdapp` command.

See “How to Globally Register an Application in the Solstice Launcher” on page 35 for information on using the `soladdapp` command to register applications globally.

Globally registered applications can only be added or removed using the `soladdapp` and `soldelapp` commands. Their properties cannot be modified from the Solstice Launcher.

If the user has a local registry file, and both a local registry and global registry file are in place, then the applications from all files are displayed.

## ▼ How to Privately Register an Application in the Solstice Launcher

The following procedure describes how to privately register an application in the user's `$HOME/.solstice_registry` file.

1. **Select Add Application from the Launcher menu.**

2. Enter the following application information in the Add Application window.
  - a. Identify the application name in the Name text box.

This name is displayed in the Launcher window.
  - b. Identify the application path name in the Application Path text box.

If you are not sure of the application path name, click on the ellipsis (...) button, which displays the Application Path Selection window. See “How to Use the File Selection Window” on page 40 for information on using this window.
  - c. Identify any command-line arguments for the application in the Arguments text box.

These arguments are passed to the application when it is started.
  - d. Identify the application icon path name in the Icon Path text box.

If you are not sure of the icon path name, click on the ellipsis (...) button, which displays the Application Path Selection window. See “How to Use the File Selection Window” on page 40 for information on using this window.
3. Click on Register to add the application.

## Example of Registering a Private Application in the Solstice Launcher

The following example registers an application called Mail Manager.

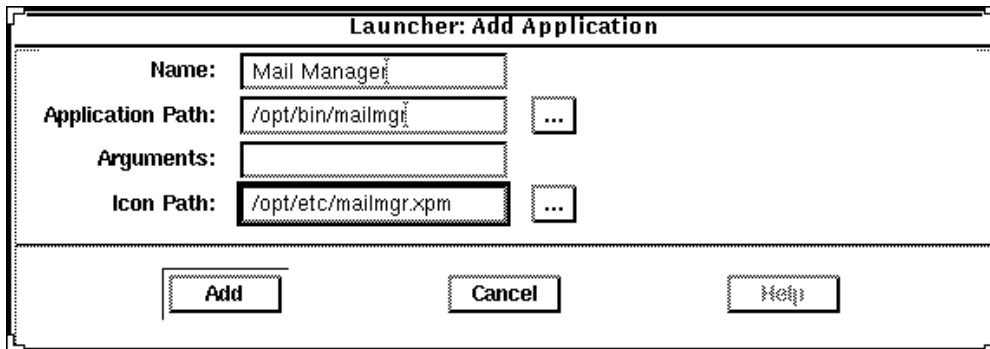

## ▼ How to Remove a Privately Registered Application

1. Select Properties from the Launcher menu.

The Properties window is displayed.



2. Select an application from the Hide or Show lists.
3. Click on the Remove button in the Properties window.
4. Click on OK.

## ▼ How to Locally Register an Application in the Solstice Launcher

1. Become root.
2. Register an application with the `soladdapp` command.

```
# /usr/snadm/bin/soladdapp \  
-r /etc/.solstice_registry \  
-n ``Tool Name`` \  
-i /opt/pkgname/etc/tool.icon \  
-e /opt/pkgname/bin/command args
```

In this command,

<code>/usr/snadm/bin/soladdapp</code>	Is the Solstice command for registering applications.
<code>-r /etc/.solstice_registry</code>	Specifies the path name of the Solstice local registry file.
<code>-n "Tool Name"</code>	Specifies the name of the tool to be registered.
<code>-i /opt/pkgname/etc/tool.icon</code>	Specifies the path name of the tool icon.
<code>-e /opt/pkgname/bin/command</code>	Specifies the path name of the tool executable.
<code>args</code>	Specifies optional arguments to use with the executable.

## Example of Registering a Local Application in the Solstice Launcher

The following example uses the `soldaddapp` command to locally register an application called Mail Manager.

```
# /usr/snadm/bin/soldaddapp \  
-r /etc/.solstice_registry \  
-n ``Mail Manager`` \  
-i /opt/SUNWdsk/etc/diskmgr.xpm \  
-e /opt/SUNWdsk/bin/diskmgr
```

## ▼ How to Remove a Locally Registered Application

1. Become root.
2. Remove an application with the `soldelapp` command.

```
# /usr/snadm/bin/soldelapp \  
-r /etc/.solstice_registry \  
-n ``Tool Name``
```

In this command,

<code>/usr/snadm/bin/soldelapp</code>	Is the Solstice command for removing applications from the local registry file.
<code>-r /etc/.solstice_registry</code>	Specifies the path name of the Solstice local registry file.
<code>-n "Tool Name"</code>	Specifies the name of the tool to be removed.

## Example of Removing a Locally Registered Application

The following example uses the `soldelapp` command to remove an application called Mail Manager.

```
# /usr/snadm/bin/soldelapp \  
-r /etc/.solstice_registry \  
-n ``Mail Manager``
```

## ▼ How to Globally Register an Application in the Solstice Launcher

1. Become root.
2. Register an application with the `soladdapp` command.

```
# /usr/snadm/bin/soladdapp \  
-r /opt/SUNWadm/etc/.solstice_registry \  
-n ``Tool Name`` \  
-i /opt/pkgname/etc/tool.icon \  
-e /opt/pkgname/bin/command args
```

In this command,

<code>/usr/snadm/bin/soladdapp</code>	Is the Solstice command for registering applications.
<code>-r /opt/SUNWadm/etc / .solstice_registry</code>	Specifies the path name of the Solstice global registry file.
<code>-n "Tool Name"</code>	Specifies the name of the tool to be registered.
<code>-i /opt/pkgname/etc/tool.icon</code>	Specifies the path name of the tool icon.
<code>-e /opt/pkgname/bin/command</code>	Specifies the path name of the tool executable.
<code>args</code>	Specifies optional arguments to use with the executable.

## Example of Registering a Global Application in the Solstice Launcher

The following example uses the `soldaddapp` command to globally register an application called Mail Manager.

```
# /usr/snadm/bin/soldaddapp \  
-r /opt/SUNWadm/etc/.solstice_registry \  
-n ``Mail Manager`` \  
-i /opt/SUNWdsk/etc/diskmgr.xpm \  
-e /opt/SUNWdsk/bin/diskmgr
```

## ▼ How to Remove a Globally Registered Application

1. Become root.

2. Remove an application with the `soldelapp` command.

```
# /usr/snadm/bin/soldelapp \  
-r /opt/SUNWadm/etc/.solstice_registry \  
-n ``Tool Name``
```

In this command,

<code>/usr/snadm/bin/soldelapp</code>	Is the Solstice command for removing applications from the global registry file.
<code>-r /opt/SUNWadm/etc/.solstice_registry</code>	Specifies the path name of the Solstice global registry file.
<code>-n "Tool Name"</code>	Specifies the name of the tool to be removed.

## Example of Removing a Globally Registered Application

The following example uses the `soldelapp` command to remove an application called Mail Manager.

```
# /usr/snadm/bin/soldelapp \  
-r /opt/SUNWadm/etc/.solstice_registry \  
-n ``Mail Manager``
```

---

## Customizing the Solstice Launcher

### ▼ How to Customize Application Properties in the Solstice Launcher

**1. Select Properties from the Launcher menu.**

The Properties window is displayed.

**2. To disable or enable the display of applications in the Launcher window, use the Hide/Show buttons.**

**a. To hide an application, select an application from the Show list and click on the Hide button.**

The application is moved to the Hide list.

**b. To show an application, select an application from the Hide list and click on the Show button.**

The application is moved to the Show list.

**c. Click on OK when you are finished moving applications to and from the Show and Hide lists.**

**3. To remove an application from a local registry file, use the Remove button.**

See “How to Remove a Privately Registered Application” on page 32 for information on removing a locally registered application.

**4. To add an application to the Launcher window, click on the Add Application button.**

The Add Application window is displayed. This window is equivalent to the Add Application command from the Launcher menu.

See “How to Privately Register an Application in the Solstice Launcher” on page 31 for information on adding applications to the Launcher.

5. If you select an application from the Hide or Show lists and click on the Application Properties button, the Application Properties window is displayed. See “How to Modify Properties of a Locally Registered Application” on page 39 for information on modifying the properties of a locally registered application.
6. Change how the tool icons are displayed in the Launcher window.
  - a. Select an application in the Show list and click on the Up or Down arrow under Icon Order to change the location of an icon.
  - b. Use the up/down arrows under Launcher Width to indicate the number of columns that will display in the Launcher window.
7. If you increase the number of icons to be wider than the width of the Launcher window, use the scrollbar at the bottom of the Launcher to view any icons that moved off the window.
8. Click on OK.

## Example of Customizing Application Properties in the Solstice Launcher

The following example shows that Database Manager has been moved to the Hide list. This means it will not be displayed in the Solstice Launcher.

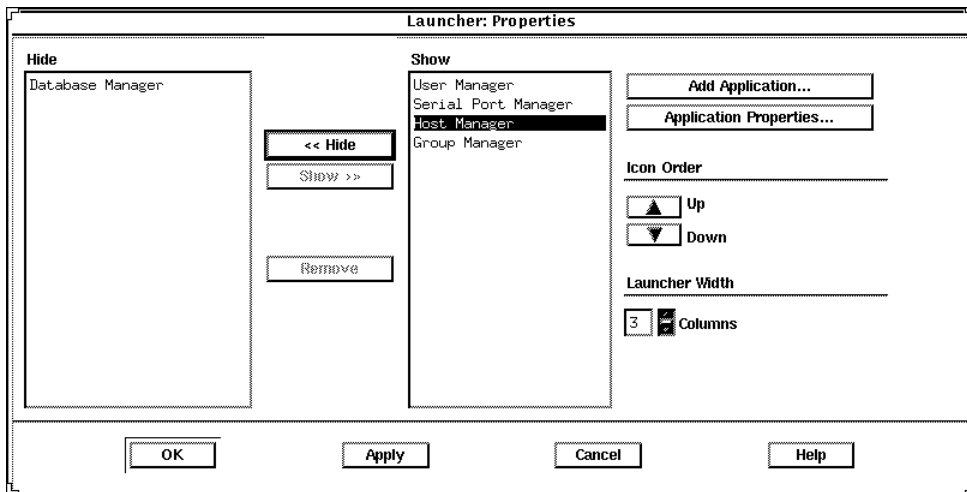

---

# Customizing Locally Registered Applications in the Solstice Launcher

Locally registered applications can be customized in the following ways:

- Applications can be hidden or redisplayed by using the Hide/Show feature.
- The number of columns in the Launcher window can be expanded and contracted, which affects how the applications are displayed.
- The application icons can be moved up or down to change the order in which the application icons are displayed.

See “How to Customize Application Properties in the Solstice Launcher” on page 37 for more information on customizing applications.

## ▼ How to Modify Properties of a Locally Registered Application

1. **Select Properties from the Launcher menu.**  
The Properties window is displayed.
2. **Select an application from the Hide or Show lists.**
3. **Click on the Application Properties button.**  
The Application Properties window is displayed.
4. **Modify the following application properties:**
  - a. **The application name in the Name text box.**

---

**Note** - The application name must be changed in order for any application properties changes to be successful.

---

- b. **The application path name in the Application Path text box.**  
If you are not sure of the application path name, click on the ellipsis (...) button, which displays the Application Path Selection window. See “How to Use the File Selection Window” on page 40 for information on using this window.
- c. **Any command-line arguments to the application in the Arguments text box.**  
These arguments are passed to the application when it is started.
- d. **The icon path name in the Icon Path text box.**

If you are not sure of the icon path name, click on the ellipsis (...) button, which displays the Application Path Selection window. See “How to Use the File Selection Window” on page 40 for information on using this window.

#### 5. Click on Register.

### Example of Modifying Properties of a Locally Registered Application

The following example provides an alternative executable and icon for Host Manager.

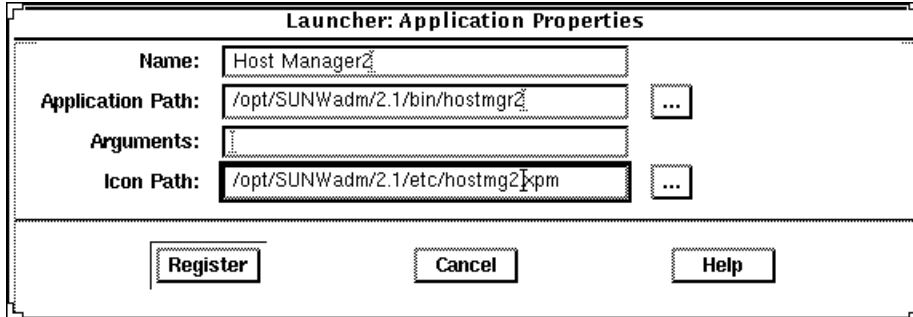

### ▼ How to Use the File Selection Window

1. Use the Filter text box in the Application Path Selection window to specify a path name using a regular expression, such as the wildcard character (\*).  
When a new value is entered, the Directories and File lists are updated appropriately.
2. Select a file name from the Files list to update the Open File text box.
3. Click on OK to place the Open File text box value into the field from which the File Selection window was invoked.  
The application file name is displayed in the Application Path text box in the Application window.

### Example of Using the File Selection Window

The following example of the Application Path Selection window uses a filter to search the /opt/SUNWadm/2.3/bin directory for application tool executables, which are displayed under the Files list.



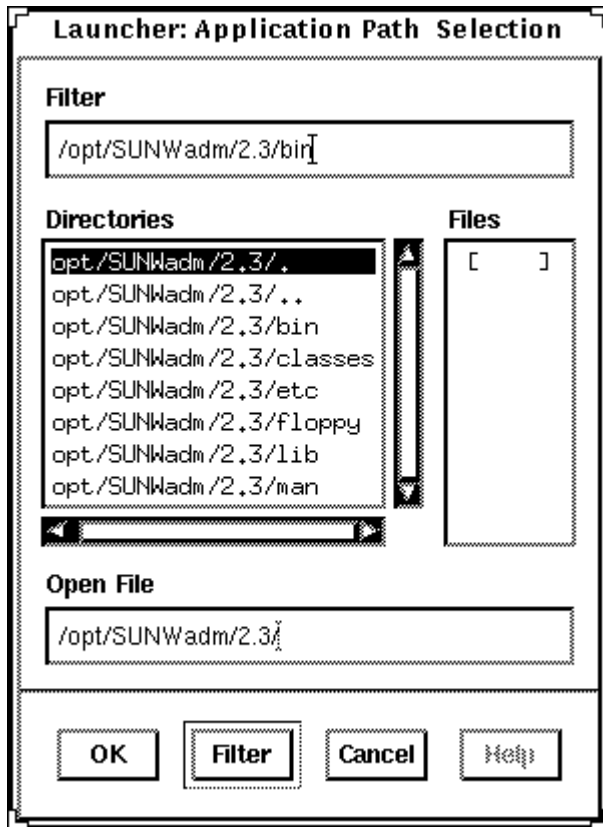



This part provides instructions for how to use the Solstice Launcher and the individual Solstice AdminSuite applications. This part contains these chapters.

- Chapter 5**                      *Solstice AdminSuite Tools Reference Information* provides information that is common across all the Solstice AdminSuite tools, such as online help and error/warning messages.
- Chapter 6**                      *Managing Server and Client Support With Host Manager* provides instructions for how to create and manage user information with User Manager and Group Manager.
- Chapter 7**                      *Managing Users With User Manager and Group Manager* provides instructions for how to set up a system with Host Manager. Also describes how to add diskless and dataless client support to a server.
- Chapter 8**                      *Managing Terminals and Modems With Serial Port Manager* provides instructions for setting up the serial port software to work with terminals and modems with the Serial Port Manager.
- Chapter 9**                      *Setting Up SunSoft Print Client Software With Printer Manager* provides instructions for how to set up print servers and print clients with Printer Manager.
- Chapter 10**                     *Managing Network Service Files With Database Manager* provides instructions for how to manage network service files with Database Manager.

## **Chapter 11**

*Managing Disks and File Systems With Storage Manager* provides instructions for how to manage disks and files system with Storage Manager, which consists of two tools: Disk Manager and File System Manager.

## Solstice AdminSuite Tools Reference Information

---

This chapter contains reference information for features found in all tools within the Solstice AdminSuite software.

This is a list of the overview information in this chapter.

- “Main Window Areas” on page 45
- “Using Admin Help” on page 46
- “Filtering System Entries With User Manager and Group Manager” on page 48
- “Filtering System Entries With Host Manager” on page 49
- “Buttons” on page 50
- “Global Browsing Capabilities With Host Manager” on page 51
- “Batching Operations With Host Manager” on page 52
- “Status Area Within Host Manager” on page 53
- “Logging Solstice AdminSuite Operations” on page 54
- “Using the `Policy_Defaults` File” on page 55
- “Using Scripts With User Manager or Host Manager” on page 58

---

### Main Window Areas

When you select a tool icon in the Solstice Launcher, the tool’s main window is displayed. Many of the tools have main window areas similar to the Host Manager’s main window shown in Figure 5-1.

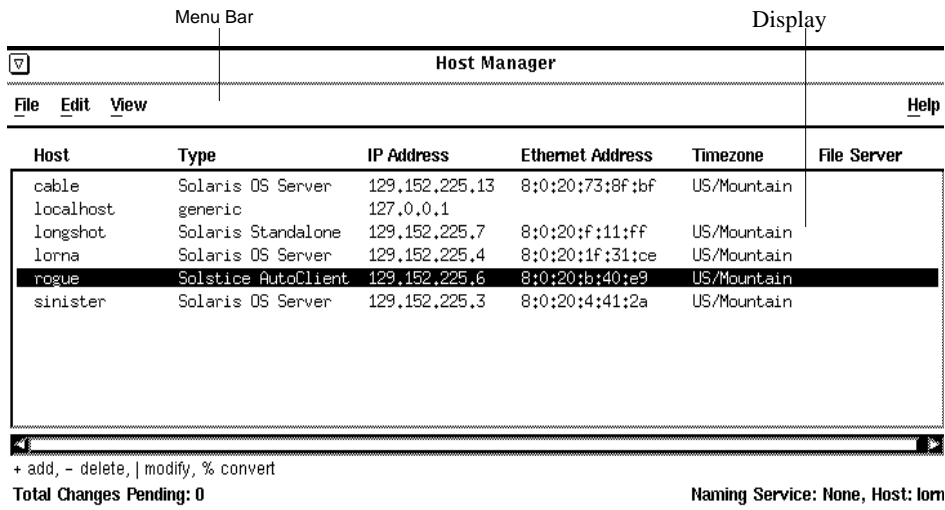

Figure 5-1 Host Manager Main Window Areas

The main window contains two areas: a menu bar and a display area. The menu bar usually contains four menus: File, Edit, View, and Help. For more information on these menus, see the online help (the section “Using Admin Help” on page 46 describes how to access online help).

Disk Manager and File System Manager have a different main window. See Chapter 11, for more details.

## Using Admin Help

An important part of the Solstice AdminSuite software is a Help utility called Admin Help. Admin Help provides detailed information about Solstice AdminSuite tools and their functions.

- To access Admin Help from a Solstice AdminSuite tool's main window, choose “About xx Manager” from the Help menu.
- To access the online help from a Solstice AdminSuite application's command window, click on the Help button.

Figure 5-2 shows the Admin Help window.

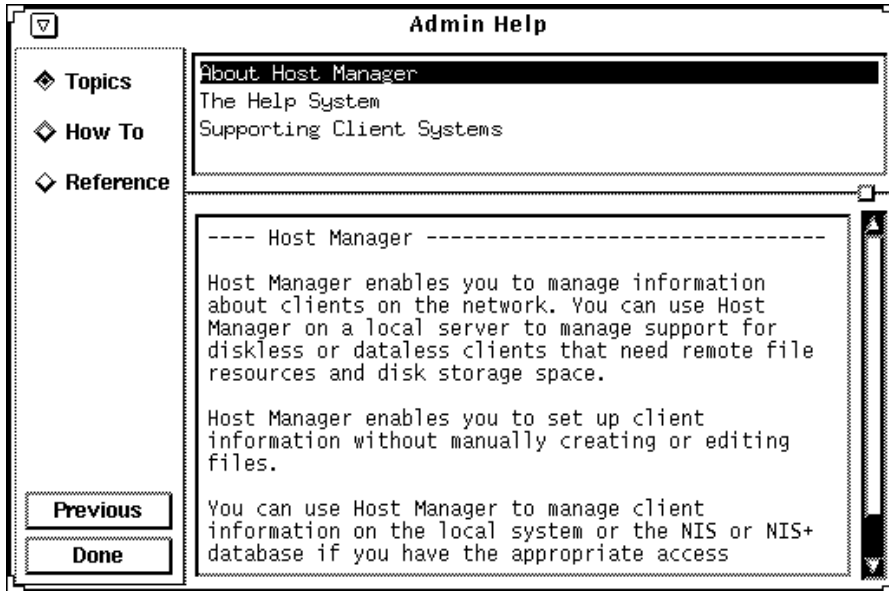

Figure 5-2 Admin Help Window

The titles displayed in the top window pane identify the list of topics available for each level of help.

The text displayed in the bottom window pane describes information about using the current menu or command.

Use the scroll bars to the right of each pane to scroll through the help information displayed.

On the left side of the Admin Help window are buttons used to find information and navigate through the help system. The buttons are described in Table 5-1.

TABLE 5-1 Admin Help Buttons

This Button ...	Is Used To ...	Notes
Topics	Displays a list of overview topics.	Click on a title in the top window pane to view the accompanying help text.
How To	Displays a list of step-by-step procedures.	Click on a title in the top window pane to view the accompanying help text.
Reference	Displays a list of more detailed information.	Click on a title in the top window pane to view the accompanying help text.

TABLE 5-1 Admin Help Buttons (continued)

This Button ...	Is Used To ...	Notes
Previous	Returns to the last accessed help text.	The help viewer automatically returns to the previous help selection.
Done	Exits the help system.	The Admin Help window is closed.

## Filtering System Entries With User Manager and Group Manager

The User Manager and Group Manager applications provide a means of filtering entries if you do not want to see all of the entries in a system file. To filter system entries, choose Load from the File menu and specify a filter from the Filter Groups menu, as shown in Figure 5-3.

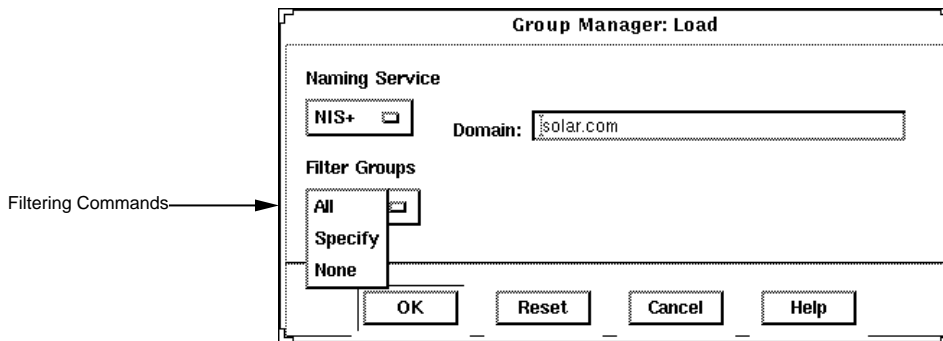

Figure 5-3 Filtering System Entries With User Manager and Group Manager

Table 5-2 describes the different filtering commands.



TABLE 5-2 Filtering Commands for User Manager and Group Manager

Use This Command ...	To ...
All	Display all file entries. This is the default setting.
Specify	Specify a text string that displayed file entries must match. Specifying wildcards is acceptable. This option is helpful if you want to focus on a small number of entries.
None	Turn off file entry display. This is helpful if you only want to add new entries and have no interest in viewing existing entries.

After you have selected a name service and a method for filtering entries that are displayed, click on OK. The tool's main window is displayed.

---

## Filtering System Entries With Host Manager

To view specific system entries in Host Manager's main window, choose Set Filter from the View menu. The Filter window is displayed and you have the option of setting from one to three filtering characteristics, as shown in Figure 5-4.

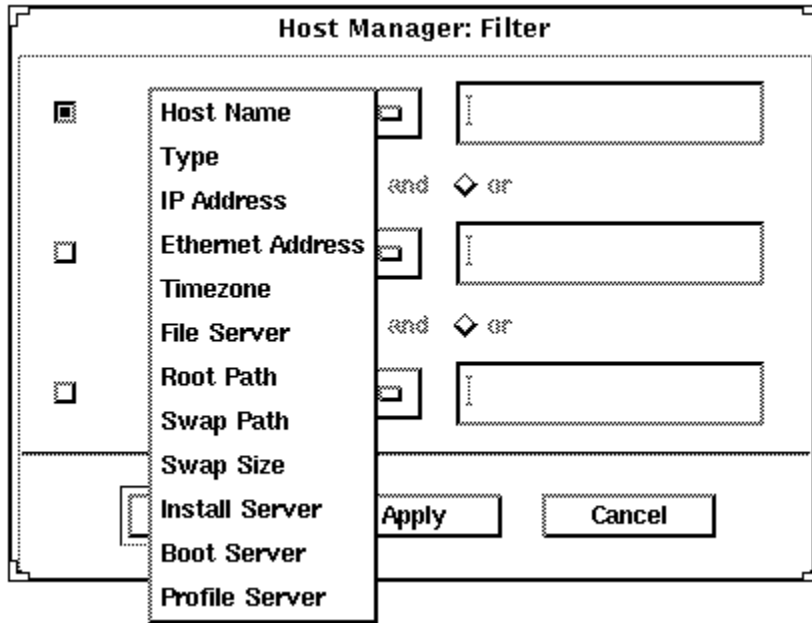

Figure 5-4 Filtering System Entries With Host Manager

After you have chosen a method for filtering the entries that are displayed in the main window, click on OK.

## Buttons

Table 5-3 describes the common window buttons used in the Solstice AdminSuite tools.

TABLE 5-3 Common Window Buttons in the Solstice AdminSuite Tools

This Button ...	Is Used To ...
OK	Complete a task so that it can be processed. The window is closed after the task is completed.
Apply	Complete a task but leave the window open. (Not available on all windows.)
Reset	Reset all fields to their original contents (since the last successful operation).

TABLE 5-3 Common Window Buttons in the Solstice AdminSuite Tools *(continued)*

This Button ...	Is Used To ...
Cancel	Cancel the task without submitting any changes and close the window. Fields are reset to their original contents.
Help	Access Admin Help.



**Caution** - Clicking on OK after clicking on Apply might cause a duplicate operation, resulting in an error. Click on Cancel after clicking on Apply to dismiss the window.

---

## Global Browsing Capabilities With Host Manager

Host Manager enables you to see most system attributes in the main window, shown in Figure 5-5. Choose Customize from the View menu to change your attribute viewing options.

## Attributes

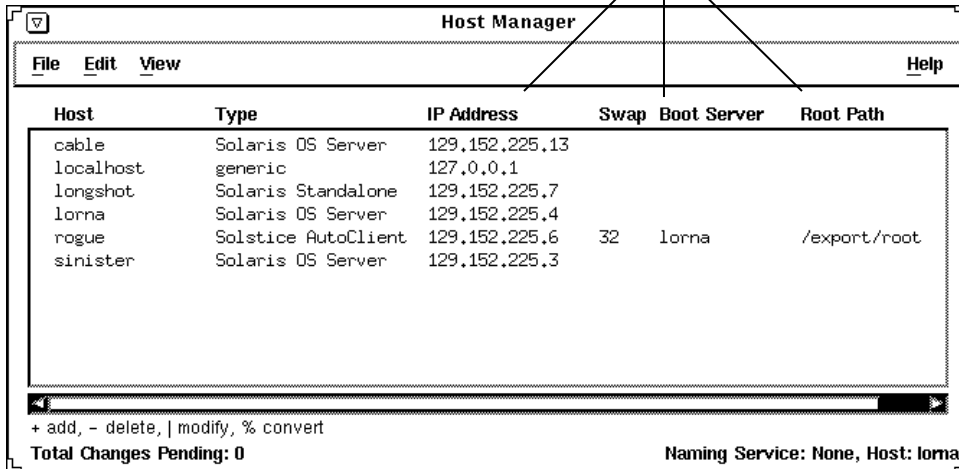

The screenshot shows the Host Manager application window. At the top, there is a title bar with the text 'Host Manager' and a standard window control icon. Below the title bar is a menu bar with 'File', 'Edit', 'View', and 'Help' options. The main area contains a table with the following columns: Host, Type, IP Address, Swap, Boot Server, and Root Path. The table lists several hosts, with 'rogue' being the only one with non-empty Swap, Boot Server, and Root Path fields. At the bottom of the window, there is a status bar with the text '+ add, - delete, | modify, % convert' and 'Total Changes Pending: 0'. On the right side of the status bar, it says 'Naming Service: None, Host: lorna'.

Host	Type	IP Address	Swap	Boot Server	Root Path
cable	Solaris OS Server	129.152.225.13			
localhost	generic	127.0.0.1			
longshot	Solaris Standalone	129.152.225.7			
lorna	Solaris OS Server	129.152.225.4			
rogue	Solstice AutoClient	129.152.225.6	32	lorna	/export/root
sinister	Solaris OS Server	129.152.225.3			

Figure 5-5 Global Browsing Capabilities With Host Manager

## Batching Operations With Host Manager

Host Manager enables you to add, delete, modify, convert, and revert more than one system at the same time, which is called *batching*. The scrolling and highlighting capabilities of the main window enable you to select multiple systems, as shown in Figure 5-6. To select more than one system, click SELECT (by default, the left mouse button) on the first system. Then select each subsequent system by pressing the Control key and clicking SELECT.

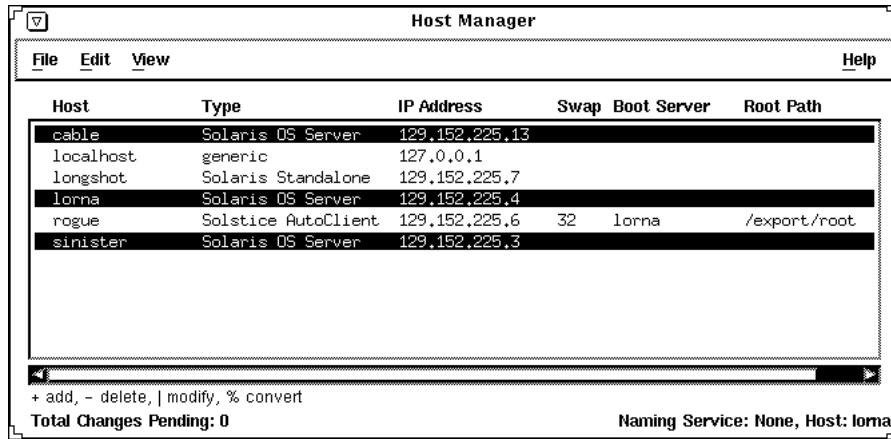

Figure 5-6 Selecting Multiple Entries Within Host Manager

## Status Area Within Host Manager

“Main Window Areas” on page 45 describes two areas of Host Manager’s main window: a menu bar area and a display area. The Host Manager main window also has a status area in the bottom of the window, which is shown in Figure 5-7.

In the left corner, the status area displays status information about pending changes, such as how many systems are waiting to be added, deleted, modified, and converted. In the right corner, the status area displays the current name service you are modifying with Host Manager.

The message “Total Changes Pending” reflects the number of systems that are waiting to be added, deleted, modified, and converted when you choose Save Changes from the File menu. After you choose “Save Changes” from the File menu, this message changes to “All Changes Successful.” If any changes did not succeed, a message is written to the Errors pop-up window.

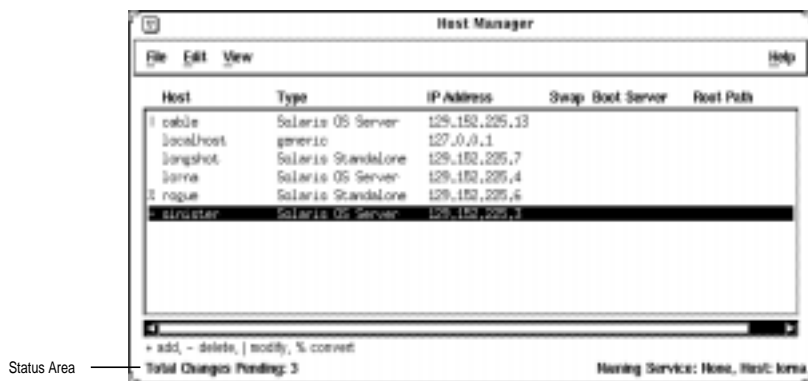

Figure 5-7 Status Information Within Host Manager

## Logging Solstice AdminSuite Operations

You can set up a log file to record each major operation completed with the Solstice AdminSuite tools or their command-line equivalents. After you enable logging, the date, time, server, user ID (UID), and description for every operation are written to the specified log file.

You need to follow the procedure described in “How to Enable Logging of Solstice AdminSuite Operations” on page 54 on each server where you run the Solstice AdminSuite software and want to maintain a logging file.

### ▼ How to Enable Logging of Solstice AdminSuite Operations

You do not need to quit a Solstice AdminSuite application or the Solstice Launcher, if they are already started.

1. **Become root.**
2. **Edit the `/etc/syslog.conf` file and add an entry at the bottom of the file that follows this format:**

```
user.info filename
```

Note that *filename* must be the absolute path name of the file, for example: `/var/log/admin.log`.

3. **Create the file, *filename*, if it does not already exist:**

```
# touch filename
```

#### 4. Make the changes to the `/etc/syslog.conf` file take effect by stopping and starting the syslog service:

```
# /etc/init.d/syslog stop
Stopping the syslog service.
# /etc/init.d/syslog start
syslog service starting.
#
```

Solstice AdminSuite operations will now be logged to the file you specified.

### Example of a Host Manager Log File

```
Nov 30 10:34:23 lorna Host Mgr: [uid=100] Get host prototype
Nov 30 10:34:52 lorna Host Mgr: [uid=100] Adding host: frito
Nov 30 10:35:37 lorna Host Mgr: [uid=100] Get host prototype
Nov 30 10:35:59 lorna Host Mgr: [uid=100] Deleting host frito
Nov 30 10:36:07 lorna Host Mgr: [uid=100] Modifying sinister with sinister
Nov 30 14:39:21 lorna Host Mgr: [uid=0] Read hosts
Nov 30 14:39:43 lorna Host Mgr: [uid=0] Get timezone for lorna
Nov 30 14:39:49 lorna Host Mgr: [uid=0] Get host prototype
Nov 30 14:40:01 lorna Host Mgr: [uid=0] List supported architectures for lorna dirpath=/cdrom/cdrom0/s0
```

---

## Using the `Policy_Defaults` File

The `Policy_Defaults` file is a file that is created when you use the Set Defaults feature from the Host Manager or User Manager Edit pull down menu; similarly, this file is created when you use the `admtblloc` command.

The `Policy_Defaults` file is used to set the default values for adding a user or host to your system; that is, if you have a standard value that you use repeatedly for a host or user, you can set that value as a default so that you do not have to enter it each time you add a user or host. Refer to the following screen for an example of the Set Defaults window in User Manager.

**User Manager: Set Add Defaults**

---

**USER IDENTITY**

Primary Group:

Secondary Groups:

Login Shell:   /bin/csh

**ACCOUNT SECURITY**

Password:

Min Change:  days

Max Change:  days

Max Inactive:  days

Expiration Date:

Warning:  days

**HOME DIRECTORY**

Create Home Dir:

Server:

Skeleton Path:

AutoHome Setup:

Permissions:	Read	Write	Execute
Owner	<input checked="" type="checkbox"/>	<input checked="" type="checkbox"/>	<input checked="" type="checkbox"/>
Group	<input checked="" type="checkbox"/>	<input type="checkbox"/>	<input checked="" type="checkbox"/>
World	<input checked="" type="checkbox"/>	<input type="checkbox"/>	<input checked="" type="checkbox"/>

**MISCELLANEOUS**

Mail Server:

---

Figure 5-8 Set Defaults Window

The `Policy_Defaults` file is created in and used by the NIS, NIS+, and None name services. Depending upon which name service is used, the file is stored in different places.

If you are using a NIS name service, the file location depends upon the following:



- A server that does not have AdminSuite loaded on it puts the file in the directory where DIR is specified in the /var/yp/Makefile.
- A server that has AdminSuite loaded puts the file in /etc.

If you are using a NIS+ name service, an actual NIS+ map is created in org\_dir called Policy\_Defaults.org\_dir.

If you are using the None name service, the file is stored in the /etc/Policy\_Defaults directory.

## Example of a Policy\_Defaults File

The Policy\_Defaults0 file consists of a number of entries that you can set; the following is an example of the Policy\_Defaults file.

```
USER_GUID=10
USER_SGUILD=
USER_SHELL=/bin/sh
USER_PASSWORD_TYPE=BLANK
USER_PASSWORD_MIN_CHANGE=
USER_PASSWORD_MAX_CHANGE=
USER_PASSWORD_MAX_INACTIVE=
USER_PASSWORD_EXPIRE=
USER_PASSWORD_WARNING=
USER_CREATE_HOME_DIR=YES
USER_SERVER=
USER_HOME=
USER_SKELETON_DIRECTORY=/etc/skel
USER_AUTO_HOME_SETUP=NO
USER_DEFAULT_PERMISSION=0755
USER_MAIL_SERVER=
USER_CRED_TABLE_SETUP=YES
MOVE_USER_MAIL=/var/mail
MOVE_USER_EXPORT_DESTINATION_HOME=YES
MOVE_USER_UNEXPORT_SOURCE_HOME=NO
MOVE_USER_EXPORT_DESTINATION_MAIL=YES
MOVE_USER_UNEXPORT_SOURCE_MAIL=NO
USER_KEY_1=internalUseOnly
CLIENT_ROOT_LOCATION=/export/root
CLIENT_SWAP_LOCATION=/export/swap
CLIENT_OS=Solaris
CLIENT_OS_VERSION=2.5
CLIENT_ARCHITECTURE=sparc
CLIENT_PLATFORM=sun4c
CLIENT_SWAP_DISKSPACE=32
KERNEL_LOCATION=/export/exec
FILE_SERVER=
MEDIA_SERVER=
```

---

# Using Scripts With User Manager or Host Manager

Using User Manager or Host Manager, you can enable scripts to be run when you add, delete, or modify a user or AutoClient. These scripts are user supplied scripts that can customize your addition, deletion, or modification of a user or AutoClient.

## Script Directory

To use these scripts with the AdminSuite tools, you must place the scripts in the following directory: `/opt/SUNWadmd/Scripts`

The AdminSuite program looks to this directory for any scripts and then lists them in the following window whenever you press the Enable Scripts button from the User Manager or Host Manager Add, Modify, or Delete windows.

---

**Note** - Scripts that modify system maps can cause problems with hosts or users being added, modified or removed; you should not create scripts that modify any of these system maps.

---

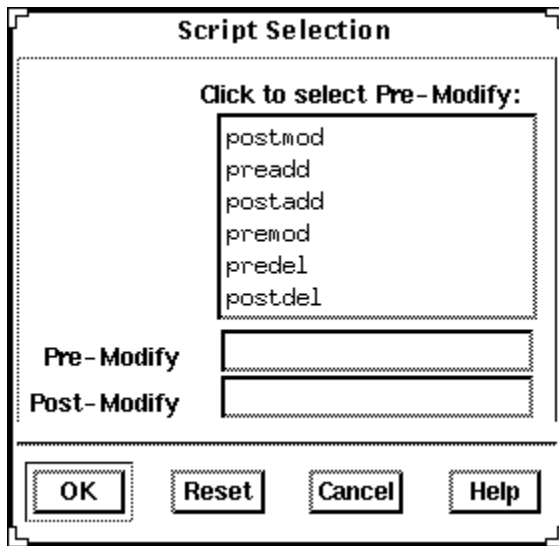

Figure 5-9 Script Selection Window

# Script Environment Variables

When you use the scripts feature, environment variables automatically get set in the script's environment. Refer to the man page `admenvron.5` for a listing of the environment variables associated with the scripts feature.

## Default Scripts

In addition to selecting user-defined scripts, by default, the following scripts run if they exist.

- `prehostadd`
- `posthostadd`
- `prehostmod`
- `posthostmod`
- `prehostdel`
- `posthostdel`
- `predisk.def`
- `postdisk.def`
- `preuseradd`
- `postuseradd`
- `preusermod`
- `postusermod`
- `preuserdel`
- `postuserdel`



## Managing Server and Client Support With Host Manager

---

This chapter describes how to set up and maintain server and client support by using the Solstice Host Manager and its corresponding command-line equivalents. This is a list of the step-by-step instructions in this chapter.

- “How to Start Host Manager” on page 81
- “How to Update System Types” on page 83
- “How to Set Defaults for Adding Support” on page 83
- “How to Add Support for a Standalone System or OS Server” on page 83
- “How to Convert a System to an OS Server” on page 88
- “How to Add SunOS 4.x OS Services to an OS Server” on page 90
- “How to Add Solaris 2.x OS Services to an OS Server” on page 95
- “How to Add JavaOS Services to an OS Server” on page 97
- “How to Remove OS Services from an OS Server” on page 98
- “How to Add Support for a Diskless Client” on page 100
- “How to Add Support for a JavaStation Client” on page 103
- “How to Add Support for a Dataless Client” on page 105
- “How to Add a Multihomed Host” on page 109
- “How to Modify Support for a System” on page 111
- “How to Delete Support for a System” on page 111

---

## What Are Servers and Clients

Systems on the network can usually be described as one of the following:

- **Server** – A system that provides services to other systems in its network. There are file servers, boot servers, database servers, license servers, print servers, installation servers, and even servers for particular applications. This chapter uses the term server to mean a system that provides file systems and installation software for other systems on the network.
- **Client** – A system that uses remote services from a server. Some clients have limited disk storage capacity, or perhaps none at all, and they have to rely on remote file systems from a server to function. Diskless and dataless clients and JavaStations are examples of this type of client.

Other clients may use remote services (such as installation software) from a server, but they don't rely on a server to function. A standalone system, which has its own hard disk containing the root (/), /usr, and /export/home file systems and swap space, is a good example of this type of client.

---

## What Does Support Mean

Providing support for a system means providing software and services to help another system function. Support can include:

- Making a system known to the network (i.e., host name and Ethernet address information)
- Providing installation services to remotely boot and install a system
- Providing operating system (OS) services to a system with limited or no disk space

---

## Overview of System Types

System types are basically defined by how they access the root (/) and /usr file systems, including the swap area. For example, standalone and server systems mount these file systems from a local disk, while diskless and dataless clients and JavaStations mount the file systems remotely, relying on servers to provide these services. Table 6-1 lists these and other differences for each system type.

TABLE 6-1 System Type Overview

System Type	Local File Systems	Local Swap?	Remote File Systems
Server	root (/) /usr /home /opt /export /export/home /export/root	Yes	optional
Standalone System	root (/) /usr /export/home	Yes	optional
Diskless Client	- none -	No	root (/) swap /usr /home
JavaStation	- none -	No	/home
Dataless Client	root (/)	Yes	/usr /home
AutoClient System	cached root (/) cached /usr	Yes	root (/) /usr /home

Table 6-2 describes how the other clients compare to a standalone system.

TABLE 6-2 Comparison of Clients Relative to a Standalone System

System Type	Centralized Administration	Performance	System	
			Disk Usage	Network Use
AutoClient System	better	similar	better	similar
Diskless Client	better	worse	better	worse
Dataless Client	similar	worse	better	worse

## Servers

A server system has the following file systems:

- The root (/) and /usr file systems, plus swap space
- The /export, /export/swap, and /export/home file systems, which support client systems and provide home directories for users
- The /opt directory or file system for storing application software

Servers can also contain the following software to support other systems:

- Operating system (OS) services for diskless clients, dataless clients, and AutoClient systems
- Solaris CD image and boot software for networked systems to perform remote installations
- JumpStart™ directory for networked systems to perform custom JumpStart installations

## Standalone Systems

A *networked standalone system* can share information with other systems in the network, but it can function autonomously because it has its own hard disk with enough space to contain the root (/), /usr, and /export/home file systems and swap space. The standalone system thus has local access to operating system software, executables, virtual memory space, and user-created files.

A *non-networked standalone system* is a standalone system with all the characteristics listed above except that it is not connected to a network.



## Diskless Clients

A *diskless client* has no disk and depends on a server for all its software and storage area. A diskless client remotely mounts its root (/), /usr, and /home file systems from a server.

A diskless client generates significant network traffic due to its continual need to procure operating system software and virtual memory space (swap) from across the network. A diskless client cannot operate if it is detached from the network or if its server malfunctions.

## JavaStation Client

The JavaStation is a client designed for zero administration. This client optimizes Java; the JavaStation client takes full advantage of the network to deliver everything from Java applications and services to complete, integrated system and network management. The JavaStation has no local administration; booting, administration, and data storage are handled by servers.

## Dataless Clients

A *dataless client* has local storage for its root (/) file system and swap space. The dataless client cannot function if detached from the network, because its executables (/usr) and user files (/home) are located across the network on the disk of a server.

A dataless client places far less demand on the server and the network than a diskless client does. Because dataless clients require less network access, a server can accommodate many more dataless clients than it can diskless clients. Also, since all the user files of all the dataless clients are stored centrally (on a server), they can be backed up and administered centrally.

---

**Note** - Dataless clients are no longer supported with operating systems later than Solaris 2.5.1; it is recommended that you use AutoClient systems instead of dataless clients.

---

## AutoClient Systems

For detailed information about AutoClient systems and how to administer them, see the *AutoClient 2.1 Administration Guide*. An AutoClient system is nearly identical to a diskless client in terms of installation and administration. It has the following characteristics:

- Requires a 100-Mbyte or larger local disk for swapping and for caching its individual root (/) file system and the /usr file system from a server
- Can be set up so that it can continue to access its cache when the server is unavailable
- Relies on servers to provide other file systems and software applications
- Contains no permanent data, making it a field replaceable unit (FRU)

---

**Note** - You must obtain a license for each AutoClient system you want to add to your network. See the *Solstice AdminSuite 2.3 Installation and Product Notes* for licensing information.

---

---

## What You Can Do With Host Manager

Host Manager is a graphical user interface that enables you to add and maintain server and client support on a network. With a name service like NIS+, you can manage system information in a centralized manner so that important system information, such as host names, do not have to be duplicated on every system in the network.

Host Manager enables you to:

- Add and modify system support
- Update system types
- Convert system types
- Add OS services
- Remove OS services
- Set up remote installation services
- Queue tasks
- Set root passwords
- Run scripts
- Create multihomed hosts

### Add and Modify System Support

Host Manager enables you to add and modify support for the following system types:

- Solstice AutoClient systems
- Solaris diskless clients

- JavaStations
- Solaris dataless clients (this client will no longer be supported with operating systems later than Solaris 2.5.1)
- Solaris standalone systems
- Solaris OS servers

For detailed information about each system type, see “Overview of System Types” on page 62.

Table 6–3 describes the server-client configurations that are supported by the Solstice AdminSuite 2.3 release of Host Manager.

**TABLE 6–3** Supported Server-Client Configurations

If You Have A ...	You Can Add OS Services and Support For ...	For the Following Releases ...
x86 server running Solaris 2.4 – or later	SPARC clients <sup>1</sup>	Solaris 2.3 – 2.5.1
	x86 clients	Solaris 2.4 – or later
SPARC server running Solaris 2.3 – or later	SPARC clients <sup>1</sup>	SunOS 4.x, Solaris 2.3 – or later
	x86 clients	Solaris 2.4 – or later

1. AutoClient systems are only supported on Solaris 2.4 or later.

**Note** - The SunOS 4.x release is only supported on SPARC systems with the Sun4, Sun4c, or Sun4m platform group. Support for the SunOS 4.x release will be removed in a later version of the Solstice AdminSuite software.

## Update System Types

Host Manager initially marks the system types of previously added systems as generic. However, you can choose Update System Types from the File menu to probe previously added systems and attempt to determine their system types. If Host Manager cannot determine the system type (for example, the system is not running the Solaris software) the systems will stay marked as generic.

**Note** - Previously added systems running Solaris 2.5 must also have the Solstice AdminSuite software installed for Host Manager to determine their system type.

The system type information is stored in the `bootparams` file in the local `/etc` files or a name service database. Host Manager will either modify an existing `bootparams` entry or add a new one such as the following for a Solaris standalone system named `mars`:

```
mars boottype=:st
```

## Convert System Types

Host Manager enables you to convert one system type to another. Table 6-4 shows what conversions you can make.

**TABLE 6-4** System Type Conversions

You Can Convert A ...	To A ...
Standalone System	AutoClient System, or OS Server
Dataless System	AutoClient System, or OS Server
AutoClient System	Standalone System
Generic System	Standalone System, or AutoClient System, or OS Server

You can add Solaris 2.x OS services during a conversion to an OS server.

## Add OS Services

A Solaris OS server is a server that provides operating system (OS) services to support diskless or dataless clients. By using Host Manager, you can add support for an OS server or convert a standalone system to an OS server.

For each platform group and Solaris release that you want to support, you must add the particular OS service to the OS server. For example, if you want to support SPARC Sun4m systems running Solaris 2.4, you must add Sun4m/Solaris 2.4 OS services to the OS server. You would also still need to add OS services to support

SPARC Sun4c systems or x86 systems running Solaris 2.4, because they are different platform groups.

You must have access to the appropriate Solaris CD image to add OS services.

---

**Note** - Although Host Manager enables you to add support for diskless and dataless clients running the Sun4.x release, you cannot add SunOS 4.x OS services using Host Manager. You must use the `install4x` command to add OS services to an OS server and then use Host Manager to add support for the SunOS 4.x client.

---

## Adding OS Services to a Server When the OS Services Have Been Patched

When adding OS services to an OS server, you may see error messages saying that you have inconsistent versions of the OS running on the server and the OS that you are trying to add. This message occurs when the installed version of the OS has packages that were previously patched and the OS services being added do not have those packages patched (because the patches have been integrated into the packages).

For example, you may have a server that is running Solaris 2.5.1; you may also have additional OS services loaded on this server, including the Solaris 2.5 sparc sun4m OS services that have been patched. If you try to add the Solaris 2.5 sparc sun4c OS services from a CD-ROM to a client of this server, you could get the following error message: To work around this problem, you will need to remove the patches related to the package that the error message listed. You can then try adding the OS services again. You may have to do this workaround for additional patches before the OS is successfully installed.

```
Error: inconsistent revision, installed package appears to
have been patched resulting in it being different than the
package on your media. You will need to backout all patches
that patch this package before retrying the add OS service
option.
```

## Remove OS Services

OS services can be removed from an OS server using Host Manager. For instance, if you no longer want to support SPARC Sun4m systems running Solaris 2.4, you can remove these OS services from the server using Host Manager. You can use Host Manager to remove Sun4.x or JavaStation support.

## Set Up Remote Installation Services

Host Manager enables you to set up systems to provide Solaris 2.x installation services for other systems on the network. You can set up the following types of installation services on a system:

- An install server – A system on the network that provides a Solaris CD image (either from a CD-ROM drive or a copy on a hard disk) for other systems to install from.
- A boot server – A system that provides boot information to other systems on the network. The boot server and the install server are usually the same system.
- A profile server – A system that contains JumpStart files for systems to perform a custom JumpStart installation.

---

**Note** - A boot server and install server are typically the same system. However, if the system to be installed is on a different subnet than the install server, a boot server is required on that subnet.

---

## Queue Tasks

Host Manager enables you to queue tasks such as converting system types and adding OS services. Since these tasks may require several minutes to process, Host Manager enables you to set up tasks to be performed without requiring you to wait for each task to be completed. After setting up the tasks, choose Save Changes from the File menu. Host Manager's progress is displayed in the message bar located at the bottom of the window as each task is processed.

## Set Root Passwords

When adding a Solstice AutoClient or Solaris Diskless client using Host Manager, you can now set the root password using the GUI just as you do when setting the group or user password.

## Enable Scripts

When you add a Solstice AutoClient using Host Manager, you have the option to enable scripts to run before or after you add the AutoClient to the server, or before or after you boot the AutoClient.

These scripts are those that you have created to customize the addition or deletion of AutoClient systems; these scripts need to be located in the

`/opt/SUNWadmd/Scripts` directory in order for the AdminSuite software to read them.

## Add a Multihomed Host

Host Manager enables you to add a multihomed host alias for servers with multiple network interfaces. For instance, if a server has more than one IP address because it is on multiple networks, it is considered a multihomed host. With Host Manager, you can specify more than one IP address for a host to make it a multihomed host.

---

## What You Can't Do With Host Manager

Table 6-5 shows the limitations of Host Manager and suggested workarounds.

**TABLE 6-5** Host Manager Limitations and Workarounds

Limitation	Workaround
Host Manager cannot automatically recognize all previously added system types.	Use the Update System Type option from the File menu the first time you use Host Manager. This option will probe systems on the network and attempt to identify their system types.
Host Manager can't add SunOS 4.x services to an OS server.	Mount a SunOS 4.x CD image and add OS services by using the <code>install4x</code> command.
Host Manager can't provide remote installations services for SunOS 4.x systems.	Install SunOS 4.x systems from the local CD-ROM drive.
Host Manager does not enable you to install patches on existing clients and servers. (However, if you have used the <code>admclientpatch</code> command to set up a patch spool directory, Host Manager will reference this spool directory and add appropriate patches for all new hosts.)	Use the <code>admclientpatch</code> command to set up a patch spool directory and to update existing servers and clients with the latest patches. See <code>admclientpatch(1M)</code> for details.

---

## Running Host Manager as Root

When running host manager as root, you will see slightly different behavior. The following list describes the limitations of running host manager as root.

- When Host Manager is started as root, you will see a dialog box describing the constraints that you will encounter.
- The name service selection dialog is forced to the local host and the text field is not editable.
- When adding a host, the file server is forced to the local host and can not be edited.
- When Remote Install is enabled in the Add, Modify, or Convert windows, the boot server is forced to the local host and can not be edited; also, the Install Server is forced to the local host and can not be edited.

---

## Command-Line Equivalents of Host Manager

Table 6-6 lists the commands that provide the same functionality as Host Manager and can be used without running an X Window System, such as the OpenWindows environment. Many of the Host Manager procedures in this chapter provide corresponding examples using the command-line equivalents. Also see “Using the Command-Line Equivalents to Automate Setup Tasks” on page 112 for more information on using the command-line equivalents in a script to automate setup tasks.

**TABLE 6-6** Command-Line Equivalents of Host Manager

<b>Command</b>	<b>Description</b>
<code>admhostadd</code>	Adds support for a new system or OS server.
<code>admhostmod</code>	Modifies an existing system or OS server. You can also add OS services to an existing OS server.
<code>admhostdel</code>	Deletes an existing system or OS server.



**TABLE 6-6** Command-Line Equivalents of Host Manager *(continued)*

Command	Description
<code>admhostls</code>	Lists the existing system entries in the selected name service.
<code>admhostls -h</code>	Lists hardware information of one or more system entries in the selected name service.

## Files Modified by Host Manager

Table 6-7 describes the system files modified by Host Manager.

**TABLE 6-7** Files Modified by Host Manager

System File	Where Modified	Description
<code>bootparams</code>	<code>/etc</code> , NIS, or NIS+	A database listing the servers that provide the paths to a client's boot and installation software and a client's root and swap areas
<code>/etc/dfs/dfstab</code>	Server providing the file services	A file containing a series of <code>share</code> commands that make file services available to the client
<code>ethers</code>	<code>/etc</code> , NIS, or NIS+	A database containing the client's Ethernet address
<code>hosts</code>	<code>/etc</code> , NIS, or NIS+	A database containing the client's host name and associated IP address
<code>timezone</code>	<code>/etc</code> , NIS, or NIS+	A database containing the client's time zone
<code>/export/root</code>	Server providing the file services	A default directory that contains root files for a diskless client or AutoClient system
<code>/export/swap</code>	Server providing the file services	A default directory that contains the swap file for a diskless client

TABLE 6-7 Files Modified by Host Manager (continued)

System File	Where Modified	Description
/var/sadm/softinfo	Solaris 2.3 server providing OS services	A directory containing a list of OS services available on Solaris 2.3 server
/var/sadm/system/admin/services	Solaris 2.4 or later server providing OS services	A directory containing a list of OS services available on a Solaris 2.4 or later server
/tftpboot	Server providing the boot services	A directory containing SPARC client booting information
/rplboot	Server providing the boot services	A directory containing x86 client booting information
/etc/inetd.conf	Server providing the boot services	A system file that starts the tftp and rpl boot daemons
cred.org_dir	NIS+	A NIS+ table used to store the host's DES and LOCAL credentials

## Setting Up a Name Service Policy

A name service policy is used to specify the location of system and network information managed by the Solstice AdminSuite software. This information can be located in the `/etc` directory for a local system, or in the NIS+ or NIS name service.

The Solstice AdminSuite software supports a *mixed-mode* name service policy. A mixed-mode name service policy enables you to specify different name services for configuration information. Note that this functionality is primarily useful with Host Manager.

You can use the `admtblloc(1M)` command to choose a mixture of name services for the Solstice AdminSuite tools to populate. For example, you can set up Host Manager to populate local `/etc` files for `bootparams` information and to populate the NIS+ tables for the other host configuration information, as shown in Figure 6-1.

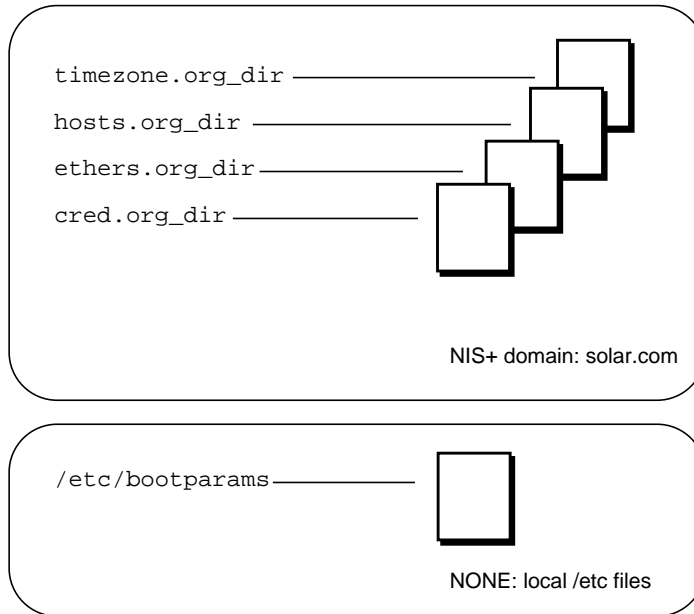

Figure 6-1 Example Mixed-Mode Name Service Policy



---

**Caution** - If you choose to implement a mixed-mode name service policy, you must run the Solstice AdminSuite software from the system containing information in the /etc directory.

---

## The admtblloc Command

The `admtblloc` command is used to implement a mixed-mode name service policy in Solstice AdminSuite. To use this command, you must have permission to use the software for each name service as described in “Setting Up User Permissions to Use Solstice AdminSuite” on page 14.

---

**Note** - The `admtblloc` command has no relation to the `/etc/nsswitch.conf` file used to set the system-wide name service selection policy in the Solaris 2.x operating environment. The `admtblloc` command is used to set the policy for all users of Solstice AdminSuite graphical user interface tools or command line interfaces.

---

### Specifying the Name Service Policy Using `admtblloc`

This example shows how to specify the name service policy specified in Figure 6-1 using the `admtblloc` command:

```
$ admtblloc -c NIS+ -d solar.com bootparams NONE
```

In this example,

- c NIS+ -d solar.com	The NIS+ domain <code>solar.com</code> is the name service <i>context</i> (the name service and domain name specified in the Load window).
bootparams	<code>bootparams</code> is the configuration file to set the name service policy for.
NONE	NONE specifies that the host running the Solstice AdminSuite tool or command line interface must use the <code>bootparams</code> file found in the local <code>/etc</code> directory.

After setting the mixed-mode name service policy specified in Figure 6-1, Solstice AdminSuite will use the `bootparams` information stored in the `/etc` directory on the current host running the Solstice AdminSuite tool whenever the name service (specified in the Load window) is NIS+. The name service policy for the other configuration files (`hosts`, `ethers`, `timezone` and `credential`) is NIS+, unless you specify otherwise using `admtblloc` again. The mixed-mode name service policy remains in effect for all users of Solstice AdminSuite in the name service until you change it using the `admtblloc` command once again.

---

**Note** - If you specify that the name service location of a configuration file is NONE using the `admtblloc` command, the `/etc` file on the current host running the Solstice AdminSuite application or command-line interface is modified. You should log in to the host where you want to use the local `/etc` file and perform operations using the Solstice AdminSuite on that system.

---

## Viewing the Name Service Policy Using `admtblloc`

This example shows how to display the name service policy using the `admtblloc` command:

```
$ admtblloc
Name      Name Service  Path
Aliases   NIS+
Hosts     NIS+
Group     NIS+
Netgroup  NIS+
Protocols NIS+
Bootparams NONE
Auto.home NIS+
```

(continued)

RPC	NIS+
Timezone	NIS+
Netmasks	NIS+
Ethers	NIS+
Passwd	NIS+
Services	NIS+
Networks	NIS+
Locale	NIS+

In this example output,

Name	Is the name of the configuration file.
Name Service	Specifies the name service used to access the configuration file.
Path	(Optional) Specifies the path to the ASCII source file on NIS servers in the NIS name service. The default is the <code>/etc</code> directory.

By default, the name service policy displayed by the `admtblloc` command is for the name service the current host is a member of. To display the name service policy for a different name service, specify the name service context.

This example shows how to display the name service policy for the `NONE` or local `/etc` files name service context domain using the `admtblloc` command:

```
$ admtblloc -c NONE
Name      Name Service Path
Aliases   NONE
Hosts     NONE
Group     NONE
Auto_home NONE
Netgroup  NONE
Protocols NONE
Bootparams NONE
RPC       NONE
Timezone  NONE
Netmasks  NONE
Ethers    NONE
Passwd    NONE
Services  NONE
Networks  NONE
Locale    NONE
```

In this example,

-c	Specifies the name service context.
NONE	Is the local /etc files name service.

You can also use the `admtblloc` command to display the name service policy for a specified configuration file. This example shows how to display the name service policy for the `hosts` file in the default name service:

```
$ admtblloc Hosts
Hosts          NIS+
```

---

**Note** - The configuration file names are case-sensitive.

---

## Configuration Files Supported by the `admtblloc` Command

Following is a list of the configuration files Solstice AdminSuite can use in a mixed-mode name service environment.

- Aliases
- Hosts
- Group
- Auto\_home
- Credentials
- Netgroup
- Protocols
- Bootparams
- Rpc
- Timezone
- Netmasks
- Ethers
- Passwd
- Services
- Networks
- Locale

---

**Note** - The `admtb1loc` command can be used to set the name service policy for only the configuration files present in this list.

---

Refer to the `admtb1loc(1M)` man page for more information about how to use this command.

---

## Adding Server and Client Support

**TABLE 6-8** Task Map: Adding Server and Client Support

Activity	Description	For Instructions, Go To
Update System Types	Optional. Make sure Host Manager recognizes all the previously added system types. This is usually a one-time task before using the AdminSuite 2.3 Host Manager for the first time.	"How to Update System Types" on page 83
Set Defaults for Adding Support	Optional. Before you add support for several clients, set up defaults for the Add window by choosing Set Defaults from the Host Manager's Edit menu. Setting up defaults can increase the consistency and efficiency of adding support for systems.	"How to Set Defaults for Adding Support" on page 83
Add Support for a Standalone System	<p>Add Support for a Standalone System</p> <p>Add support for a standalone system by choosing Add from the Host Manager's Edit menu. Once in the Add window, choose Standalone System from the System Type menu.</p> <p>You can also convert a AutoClient system or generic system to a standalone system by choosing Convert to Standalone from the Edit menu.</p>	"How to Add Support for a Standalone System or OS Server" on page 83

---

**TABLE 6-8** Task Map: Adding Server and Client Support *(continued)*

<b>Activity</b>	<b>Description</b>	<b>For Instructions, Go To</b>
Add Support for an OS Server	Add Support for an OS Server Add support for an OS server by choosing Add from the Host Manager's Edit menu. Once in the Add window, choose OS Server from the System Type menu.	"How to Add Support for a Standalone System or OS Server" on page 83
	Convert a Standalone System to an OS Server Convert a standalone system to an OS server by choosing Convert from the Host Manager's Edit menu. You can add Solaris 2.x OS services during the conversion.	"How to Convert a System to an OS Server" on page 88
Add OS Services to an OS Server	Add SunOS 4.x OS Services If you need to add support for SunOS 4.x diskless or dataless clients, an OS server must have the appropriate SunOS 4.x services added.	"How to Add SunOS 4.x OS Services to an OS Server" on page 90
	Add Solaris 2.x OS Services If you need to add support for Solaris 2.x diskless clients, dataless clients, or AutoClient systems, an OS server must have the appropriate Solaris 2.x services added.	"How to Add Solaris 2.x OS Services to an OS Server" on page 95
	Add JavaOS Services If you need to add support for JavaStation clients, an OS server must have the appropriate JavaOS™ services added.	"How to Add JavaOS Services to an OS Server" on page 97
Remove OS Services from an OS Server	Remove OS Services If you need to remove OS services from an OS server because you no longer need to support it, choose Delete from the Host Manager Modify window.	"How to Remove OS Services from an OS Server" on page 98



**TABLE 6–8** Task Map: Adding Server and Client Support (continued)

Activity	Description	For Instructions, Go To
Add Support for Clients	<p>Add Support for AutoClient Systems</p> <p>Add support for an AutoClient system by choosing Add from the Host Manager’s Edit menu. Once in the Add window, choose Solstice Autoclient System from the System Type menu.</p>	<p><i>Solstice AutoClient 2.1 Administration Guide</i></p>
	<p>Add Support for a Diskless Client</p> <p>Add support for a diskless client by choosing Add from the Host Manager’s Edit menu. Once in the Add window, choose Solaris Diskless Client from the System Type menu.</p>	<p>“How to Add Support for a Diskless Client” on page 100</p>
	<p>Add Support for a JavaStation Client</p> <p>Add support for a JavaStation client by choosing Add from the Host Manager’s Edit menu. Once in the Add window, choose JavaStation from the System Type menu.</p>	<p>“How to Add Support for a JavaStation Client” on page 103</p>
Add Support for Clients (continued)	<p>Add Support for a Dataless Client</p> <p>Add support for a dataless client by choosing Add from the Host Manager’s Edit menu. Once in the Add window, choose Solaris Dataless Client from the System Type menu.</p>	<p>“How to Add Support for a Dataless Client” on page 105</p>
Creating a Multihomed Host	<p>Add a Multihomed Host</p> <p>Add a Multihomed host by choosing Add from the Host Manager’s Edit menu. Once in the Add window, enter the name of the host that already has one IP address; the Add window will change to the Multihomed Host window.</p>	<p>“How to Add a Multihomed Host” on page 109</p>

## ▼ How to Start Host Manager

1. **Verify that the prerequisites described in Chapter 1, are met.**
2. **Start the Solstice Launcher.**

```
$ solstice &
```

The Solstice Launcher is displayed.

**3. Click on the Host Manager icon.**



## Host Manager

The Load window is displayed.

**4. Select the name service used in your network.**

**5. Check that the domain or host name is correct.**

If not, type the domain or host name you need to access.

**6. Click on OK.**

The Host Manager main window is displayed.

## Example of a Host Manager Main Window

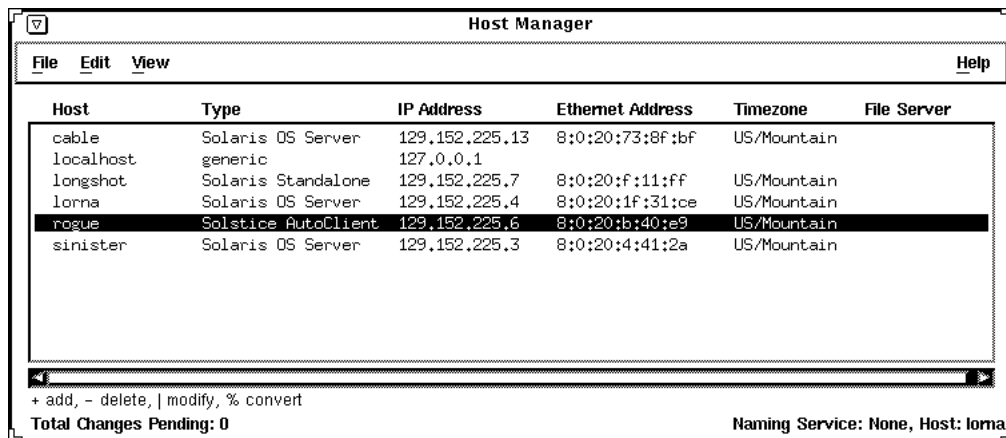

The screenshot shows the Host Manager application window. It has a menu bar with 'File', 'Edit', 'View', and 'Help'. Below the menu bar is a table with the following columns: Host, Type, IP Address, Ethernet Address, Timezone, and File Server. The table contains six rows of host information. The 'rogue' row is highlighted. At the bottom of the window, there is a status bar with the text '+ add, - delete, | modify, % convert', 'Total Changes Pending: 0', and 'Naming Service: None, Host: lorna'.

Host	Type	IP Address	Ethernet Address	Timezone	File Server
cable	Solaris OS Server	129.152.225.13	8:0:20:73:8f:bf	US/Mountain	
localhost	generic	127.0.0.1			
longshot	Solaris Standalone	129.152.225.7	8:0:20:f:11:ff	US/Mountain	
lorna	Solaris OS Server	129.152.225.4	8:0:20:1f:31:ce	US/Mountain	
rogue	Solstice AutoClient	129.152.225.6	8:0:20:b:40:e9	US/Mountain	
sinister	Solaris OS Server	129.152.225.3	8:0:20:4:41:2a	US/Mountain	

+ add, - delete, | modify, % convert  
Total Changes Pending: 0  
Naming Service: None, Host: lorna

## ▼ How to Update System Types

This procedure attempts to determine the system types for systems marked as generic.

1. **Start Host Manager from the Solstice Launcher and select the name service, if not done already.**  
See “How to Start Host Manager” on page 81 for more information.
2. **Select Update System Types from the File menu on the Host Manager Window.**  
The Update Systems Types window is displayed.
3. **Click on Update to update the systems marked as generic.**

### Command-Line Equivalent for Updating System Types

You can also use the `admhostmod -x type=type host` command to update a system type.

## ▼ How to Set Defaults for Adding Support

1. **Start Host Manager from the Solstice Launcher and select the name service, if not done already.**  
See “How to Start Host Manager” on page 81 for more information.
2. **Choose Set Defaults from the Edit menu.**  
The Set Add Defaults window is displayed.
3. **Fill in the Set Add Defaults window.**  
The defaults you select will be the initial defaults values in the Add window. If you need information to complete a field, click on the Help button to see field definitions for this window.
4. **Click on OK.**

### Command-Line Equivalent for Updating System Types

You can also use the `admhostadd -D` command to set up defaults for adding support.

## ▼ How to Add Support for a Standalone System or OS Server

The high-level steps in this procedure are:

- Add system information about the system.
  - (Optional) Set up remote install capabilities for the system.
  - (Optional) Install the system.
- 1. Start Host Manager from the Solstice Launcher and select the name service, if not done already.**

See “How to Start Host Manager” on page 81 for more information.
  - 2. Choose Add from the Edit menu on the Host Manager window.**

The Add window is displayed.
  - 3. Fill in the system information, selecting Solaris Standalone or OS Server as the system type.**

The system information includes all the fields from the host name through the time zone. If you need information to complete a field, click on the Help button to see field definitions for this window.
  - 4. If you want to set up remote install capabilities for the system, continue to Step 5 on page 84. If not, skip to Step 10 on page 85.**
  - 5. Click on Enable Remote Install.**
  - 6. Select an Install Server.**

The Install Server defaults to the current host. Select Other from the Install Server menu to specify another host as the install server.
  - 7. Click on Set Path to identify the path to the Solaris CD image on the install server.**

If the install server is a remote system, note that it must be minimally set up as a managed system.

If You Are Using ...	And ...	Then Enter the Path ...
The Solaris CD as the Solaris CD image	The Solaris CD is managed by Volume Management	/cdrom/cdrom0 or /cdrom/cdrom0/s0 or /cdrom/cdrom0/s2
	The Solaris CD is not managed by Volume Management	Where you mounted the Solaris CD
A copy of the Solaris CD on the install server's hard disk (by using setup_install_server)		To the Solaris CD image

**8. Select the system's architecture type and OS release from the OS Release menu.**

The architecture type must match the system's architecture and the OS release should match the Solaris release you want to remotely install on the system.

**9. If necessary, specify a boot server and/or profile server.**

To specify another server other than the default, select Other from the menu. Select a Profile Server from the Profile Server pull-down menu. You must also specify a path to the boot software on the boot server or the custom JumpStart directory on the profile server.

To set up the other components of a custom JumpStart installation and preconfiguring network and system information, see *Solaris Advanced Installation Guide* and *x86: Installing Solaris Software*.

**10. Click on OK on the Add window.**

**11. Select Save Changes from the File menu to add support for the standalone system or OS server.**

The standalone system or OS server is displayed in the Host Manager main window.

**12. (Optional) Boot and install the standalone system or OS server.**

For more information about booting and installing, see *Solaris Advanced Installation Guide* or *x86: Installing Solaris Software*.

---

**Note** - If you are installing an OS server, you must allocate space in /export and /export/swap for the desired number of clients.

---

## Example of a Completed Add Window for a Standalone System

The screenshot shows a dialog box titled "Host Manager: Add" with the following fields and options:

- Host Name:** venus
- IP Address:** 129.152.225.2
- Ethernet Address:** 8:0:20:b:40:e8
- System Type:** Solaris Standalone
- Timezone Region:** United States
- Timezone:** Mountain
- Remote Install:**  Enable Remote Install
- Install Server:** cable (with a "Set Path..." button)
- OS Release:** (empty)
- Boot Server:** none (with an empty text field)
- Profile Server:** none (with an empty text field)

At the bottom of the dialog are five buttons: OK, Apply, Reset, Cancel, and Help.

## Example of a Command-Line Equivalent for Adding a Standalone System

The following command is equivalent to using Host Manager to add a standalone system to the name service database.

```
% admhostadd -i 129.152.225.2 -e 8:0:20:b:40:e9 -x type=STANDALONE\  
-x tz=US/Mountain venus
```

In this command,

-i 129.152.225.2	Specifies the IP address of the system.
-e 8:0:20:b:40:e9	Specifies the Ethernet address of the system.
-x type=STANDALONE	Specifies the type of the system.
-x tz=US/Mountain	Specifies the system's timezone.
venus	Specifies the name of the system.

### Example of a Command-Line Equivalent for Adding a Standalone System and Enabling Remote Installation

The following command is equivalent to using Host Manager to add a standalone system and to enable a network installation.

```
% admhostadd -i 129.152.225.2 -e 8:0:20:b:40:e9 -x type=STANDALONE \  
-x tz=US/Mountain -x install=Y -x installpath=cable:/cdrom/cdrom0/s0\  
venus
```

In this command,

-i 129.152.225.2	Specifies the IP address of the system.
-e 8:0:20:b:40:e9	Specifies the Ethernet address of the system.
-x type=STANDALONE	Specifies the type of the system.
-x tz=US/Mountain	Specifies the system's timezone.
-x install=Y	Specifies that remote installation is enabled.
-x installpath= cable:/ cdrom/cdrom0/s0	Specifies that the Solaris CD image is on a mounted CD on a remote system named <code>cable</code> . Note that the remote system must be minimally set up as a managed system.
venus	Specifies the name of the system.

## Where to Go From Here

If you want to add OS services after you install an OS server, see “How to Add Solaris 2.x OS Services to an OS Server” on page 95.

### ▼ How to Convert a System to an OS Server

1. **Start Host Manager from the Solstice Launcher and select the name service, if not done already.**

See “How to Start Host Manager” on page 81 for more information.

2. **Select a host entry from Host Manager’s main window.**

You can convert a standalone system, dataless client, and generic system to an OS server.

3. **Choose Convert to OS Server from the Edit menu.**

The Convert window is displayed, and the selected system is displayed in the host name field.

4. **Click on the Add button in the OS Services window to add services.**

5. **Click on Set Path to identify the path to the Solaris CD image from which to add the client services.**

The Install Server defaults to the current host. Select Other from the Install Server menu to specify another host as the install server. Note that a remote system must be minimally set up as a managed system.

If You Are Using ...	And ...	Then Enter the Path ...
The Solaris CD as the Solaris CD image	The Solaris CD is managed by Volume Management	/cdrom/cdrom0 or /cdrom/cdrom0/s0 or /cdrom/cdrom0/s2
	The Solaris CD is not managed by Volume Management	Where you mounted the Solaris CD
A copy of the Solaris CD on the Install Server’s hard disk (by using setup_install_server)		Where you specified setup_install_server to copy the Solaris CD

6. **Specify the type of services you want to add and click on Add.**



The OS service is added to the OS Services list and marked with a plus sign (+), which means it will be added when you save changes. You can use the Delete button to delete an OS service from the list before you save changes.

7. Click on OK on the Convert window.
8. Select Save Changes from the File menu to convert the system to an OS Server.  
The converted system is displayed as an OS server in the Host Manager main window.

### Example of a Completed Convert Window

Each OS service consists of an architecture, platform, and OS Release. OS services marked with a plus sign (+) are added when you save changes. You can use the Delete button to delete services; OS services marked with a minus sign (-) are removed when you save changes.

The screenshot shows the 'Host Manager: Convert' dialog box. It has the following fields and controls:

- Host Name:** longshot
- System Type:** Solaris OS Server
- Timezone Region:** United States
- Timezone:** Mountain
- Remote Install:**  Enable Remote Install
- Install Server:** cable (with a 'Set Path...' button)
- OS Release:** (empty)
- Boot Server:** none
- Profile Server:** none
- OS Services:** A list containing two entries: '+ sparc sun4c Solaris 2.5' and '+ sparc sun4m Solaris 2.5'. Below the list are 'Add...' and 'Delete' buttons.

At the bottom of the dialog box are buttons for 'OK', 'Reset', 'Cancel', and 'Help'.

## Example of a Command-Line Equivalent for Converting a Standalone to an OS Server

The following command is equivalent to using Host Manager to convert a standalone system to an OS server.

```
% admhostmod -x type=OS_SERVER minnie
```

## Example Command-Line Equivalent for Adding Services to an OS Server

The following command is equivalent to using Host Manager to add OS services on an OS server.

```
% admhostmod -x mediapath=jupiter:/cdrom/cdrom0/s0\  
-x platform=sparc.sun4m.Solaris_2.5minnie
```

In this command,

<code>-x mediapath= jupiter:/cdrom/ cdrom0/s0</code>	Specifies that the Solaris CD image is on a mounted CD on a remote system named <code>jupiter</code> . Note that the remote system must be minimally set up as a managed system.
<code>-x platform= sparc.sun4m.Solaris_2.5</code>	Specifies the services to be installed, in this case the Solaris 2.5 services for a SPARC Solaris, Sun4m kernel architecture.
<code>minnie</code>	Specifies the name of the OS server.

## ▼ How to Add SunOS 4.x OS Services to an OS Server

---

**Note** - SunSoft plans to remove support for the SunOS 4.x release in a later version of the Solstice AdminSuite software. Also, you cannot add SunOS 4.x services to x86 servers.

---

The high-level steps in this procedure are:

- Determine the OS server to which you want to add SunOS 4.x OS services for diskless and dataless clients.
- Verify that the SunOS 4.x heterogeneous install software is installed.
- Install the required SunOS 4.x release software (`install4x` command).

1. Log in as root on the OS server to which you want to add SunOS 4.x OS services for diskless and dataless clients.
2. Verify that the SunOS 4.x heterogeneous install software is installed.

```
# pkginfo SUNWhinst
```

If the package information is displayed, proceed to Step 7 on page 91. If not, go to the next step.

3. Insert the Solaris 2.x CD into your CD-ROM drive.

This step assumes that your system is running Volume Management.

---

**Note** - Use the Solaris 2.x CD that matches the Solaris 2.x release that is installed on the OS server. For example, use the Solaris 2.4 11/94 CD if the OS server is running the Solaris 2.4 11/94 release.

---

To access the SunOS 4.x CD from another system running either the Solaris 2.x release or the SunOS 4.x release, see "Setting Up the CD-ROM Drive for install4x" in the *Solaris 1.x to 2.x Transition Guide*.

4. Change directory to the location of the software.

```
# cd /cdrom/cdrom0/s0/Solaris_2.x
```

5. Install the SunOS 4.x heterogeneous install software.

```
# pkgadd -d `pwd` SUNWhinst
```

6. Eject the Solaris 2.x CD.

```
# cd  
# eject cd
```

7. Insert the SunOS 4.x release CD into your CD-ROM drive.

This step assumes that your system is running Volume Management, and the CD-ROM drive is directly attached to the server. Volume Management automatically mounts the CD directory on /cdrom/volume1/s0.

## 8. Start the SunOS 4.x release software installation program.

```
# /usr/sbin/install4x -m /cdrom/volume1/s0 -e /export
```

The main menu is displayed.

```
*** 4.1* Install Main Menu ***

Choose an Architecture (then select modules to load):

          Modules
        Loaded  Selected
[a] sun4.sun4c.sunos.4.1.2    0    0
[b] sun4.sun4c.sunos.4.1.2    0    0
[c] sun4.sun4m.sunos.4.1.2    0    0

or begin the loading process for all selected modules:

[L] Load selected modules

or abort without loading any modules:

[Q] Quit without loading

Type any bracketed letter to select that function.

Type ? for help.

Disk Usage:
0K Selected
53634K Free
```

## 9. On the main menu, specify the architecture you want to support by typing the associated character that is shown in brackets.

The Module Selection menu is displayed.

Select sun4.sun4c.sunos.4.1.2 modules:

```
+ [a] R proto root.....240K      | [o] User_Diag.....6352K
+ [b] R usr.....26240K          | [p] Manual.....7456K
+ [c] R Kvm.....4832K           | + [q] D TLL.....48K
+ [d] R Install.....936K        | [r] D RFS.....912K
[e] D Networking.....1040K      | [s] D Debugging.....2928K
[f] D System_V.....4008K       | [t] SunView_Programmers.....1840K
[g] D Sys.....5288K             | [u] Shlib_Custom.....1376K
[h] C SunView_Users.....2664K   | [v] Graphics.....1784K
[i] SunView_Demo.....512K       | + [w] uucp.....608K
+ [j] Text.....712K             | + [x] Games.....3136K
[k] Demo.....4264K              | [y] Versatec.....5960K
[l] C OpenWindows_Users.....25936K | [z] Security.....312K
[m] C OpenWindows_Demo.....4288K | [A] OpenWindows_Programmers.10200K
[n] C OpenWindows_Fonts.....7840K |
```

Module + = already loaded R = Required C = Common

Legend: \*\* = selected for loading D = Desirable Others are optional

Select [a-A] or a Quick-Pick Option:

```
[1] All Required Modules  [4] All Optional Modules
[2] All Desirable Modules [5] All Modules
[3] All Common Modules
```

```
Disk Usage:
0K Selected
53634K Free
```

or [D] (done) to return to the main screen

## 10. Select modules to load by typing the associated character that is shown in brackets.

The Module Selection screen readily enables you to pick groups of modules to be loaded. When you enter a 1, it marks all required modules for loading. When you enter a 2, it marks all recommended modules. When you enter a 3, it marks all commonly loaded modules. When you enter a 4, it marks all optional modules. When you enter a 5, it marks all modules shown on the Module Selection screen.

## 11. Return to the main menu by typing D.

The main menu is displayed.

\*\*\* 4.1\* Install Main Menu \*\*\*

Choose an Architecture (then select modules to load):

	Modules	
	Loaded	Selected
[a] sun4.sun4c.sunos.4.1.2	0	4
[b] sun4.sun4.sunos.4.1.2	0	3
[c] sun4.sun4m.sunos.4.1.2	0	1

or begin the loading process for all selected modules:

[L] Load selected modules

or abort without loading any modules:

[Q] Quit without loading

Type any bracketed letter to select that function.

Type ? for help.

Disk Usage:

0K Selected

53634K Free

**12. Type L to install the software.**

The modules you previously selected are installed.

```
Installing module 'proto root' [size: 248K]
      in directory /export/exec/proto.root.sunos.4.1.2 ...
Updating server databases ...
Press any key to continue:
```

**13. After the modules are installed, press any key to return to the main menu.**

The loaded modules are displayed in the main menu.

**14. If you want to add support for other architectures, repeat Step 9 on page 92 through . Otherwise, type Q to exit.**

---

**Note** - There is no command-line equivalent for adding SunOS 4.x services to an OS server.

---

## Where to Go From Here

If you want to add SunOS 4.x support for a diskless client, see “How to Add Support for a Diskless Client” on page 100. If you want to add SunOS 4.x support for a dataless client, see “How to Add Support for a Dataless Client” on page 105.

### ▼ How to Add Solaris 2.x OS Services to an OS Server

1. **Start Host Manager from the Solstice Launcher and select the name service, if not done already.**

See “How to Start Host Manager” on page 81 for more information.

2. **Select an OS server to modify from the Host Manager main window.**

3. **Select Modify from the Edit menu on the Host Manager window.**

The Modify window is displayed.

4. **Click on the Add button in the OS Services window to add services.**

5. **Click on Set Path to identify the path to the Solaris CD image from which to add the client services.**

The Install Server defaults to the current host. Select Other from the Install Server menu to specify another host as the install server. Note that a remote system must be minimally set up as a managed system.

<b>If You Are Using ...</b>	<b>And ...</b>	<b>Then Enter the Path ...</b>
The Solaris CD as the Solaris CD image	The Solaris CD is managed by Volume Management	/cdrom/cdrom0 or /cdrom/cdrom0/s0 or /cdrom/cdrom0/s2
	The Solaris CD is not managed by Volume Management	Where you mounted the Solaris CD
A copy of the Solaris CD on the Install Server's hard disk (by using setup_install_server)		Where you specified setup_install_server to copy the Solaris CD

6. **Specify the type of services you want to add and click on Add.**

The OS service is added to the OS Services list and marked with a plus sign (+), which means it will be added when you save changes. You can use the Delete button to delete an OS service from the list before you save changes.

7. Click on OK on the Add window.

8. Select Save Changes from the File menu to add services.

### Example of a Completed Add OS Services Window

The screenshot shows a dialog box titled "Host Manager: Modify". It contains the following fields and options:

- Host Name: loma
- IP Address: 129.152.225.4
- Ethernet Address: [8:0:20:1f:31:ce]
- System Type: Solaris OS Server
- Timezone Region: United States
- Timezone: Mountain
- Remote Install:  Enable Remote Install
- Install Server: loma [Set Path...]
- OS Release: [ ]
- Boot Server: none [ ]
- Profile Server: none [ ]
- OS Services: i386 i86pc Solaris 2.5, sparc sun4c Solaris 2.4, sparc sun4m Solaris 2.4
- Buttons: Add..., Delete
- Bottom Buttons: OK, Apply, Reset, Cancel, Help

Each OS service consists of an architecture, platform, and OS Release. OS services marked with a plus sign (+) are added when you save changes. You can use the Delete button to delete services; OS services marked with a minus sign (-) are removed when you save changes.



## Example of a Command-Line Equivalent for Adding Services to an OS Server

The following command is equivalent to using Host Manager to add OS services on an OS server.

```
% admhostmod -x mediapath=jupiter:/cdrom/cdrom0/s0 -x platform=sparc.sun4c.Solaris_2.5
rogue
```

In this command,

<code>-x mediapath= jupiter:/cdrom/ cdrom0/s0</code>	Specifies that the Solaris CD image is on a mounted CD on a remote system named <code>jupiter</code> . Note that the remote system must be minimally set up as a managed system.
<code>-x platform= sparc.sun4c.Solaris_2.5</code>	Specifies the services to be installed, in this case the Solaris 2.5 services for a SPARC Solaris, Sun4c kernel architecture.
<code>rogue</code>	Specifies the name of the OS server.

### ▼ How to Add JavaOS Services to an OS Server

1. **Start Host Manager from the Solstice Launcher and select the name service, if not done already.**

See “How to Start Host Manager” on page 81 for more information.

2. **Select an OS server to modify from the Host Manager main window.**

3. **Select Modify from the Edit menu on the Host Manager window.**

The Modify window is displayed.

4. **Click on the Add button in the OS Services window to add services.**

5. **Click on Set Path to identify the path to the JavaOS image from which to add the OS services.**

The Install Server defaults to the current host. Select Other from the Install Server menu to specify another host as the install server. Note that a remote system must be minimally set up as a managed system.

<b>If You Are Using ...</b>	<b>And ...</b>	<b>Then Enter the Path ...</b>
The JavaOS as the JavaOS CD image	The JavaOS CD is managed by Volume Management	/cdrom/cdrom0 or /cdrom/cdrom0/s0 or /cdrom/cdrom0/s2
	The JavaOS CD is not managed by Volume Management	Where you mounted the JavaOS CD

**6. Specify the type of services you want to add and click on Add.**

The OS service is added to the OS Services list and marked with a plus sign (+), which means it will be added when you save changes. You can use the Delete button to delete an OS service from the list before you save changes.

**7. Click on OK on the Add window.**

**8. Select Save Changes from the File menu to add services.**

## ▼ How to Remove OS Services from an OS Server

**1. Start Host Manager from the Solstice Launcher and select the name service, if not done already.**

See “How to Start Host Manager” on page 81 for more information.

**2. Select an OS server to modify from the Host Manager main window.**

**3. Select Modify from the Edit menu on the Host Manager window.**

The Modify window is displayed.

**4. Select the OS services you wish to remove from the list.**

OS services that are installed on the system have a + sign in front of the name.

**5. Click on Delete button in the OS Services window to delete the OS services.**

---

**Note** - When you select an OS services for a particular version (i.e. sparc), all OS services for that version, regardless of what platform it is running on, will be deleted.

---

## Example of a Completed Modify Window for Removing OS Services

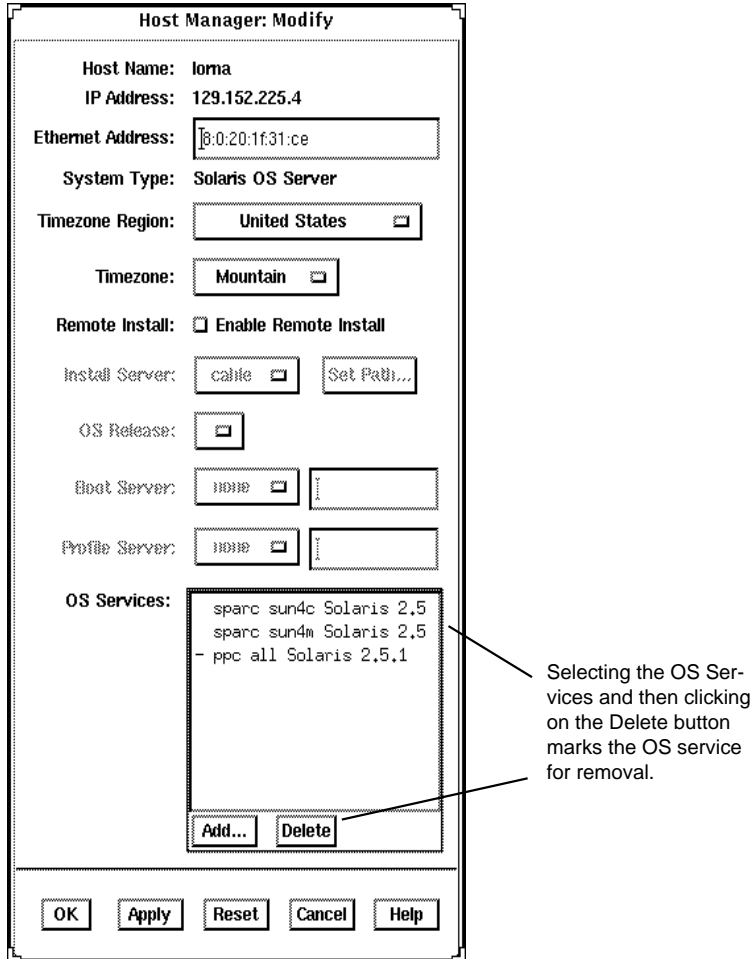

## Example of a Command-Line Equivalent for Removing Services from an OS Server

The following command is equivalent to using Host Manager to remove OS services from an OS server.

```
% admhostmod -x rmlatform=sun4.all.sunos_4.1.1 rogue
```

In this command,

<code>-x rmpatform=sun4.all.sun</code>	Specifies the services to be removed, in this case
<code>os_4.1.1</code>	SunOS4 .1.1 services
<code>rogue</code>	Specifies the name of the OS server.

## ▼ How to Add Support for a Diskless Client

The high-level steps in this procedure are:

- Add system information about the diskless client.
- Select OS services for the diskless client.
- Boot the diskless client.

---

**Note** - This procedure assumes the system providing the services (the file server) has already been configured as an OS server.

---

1. **Start Host Manager from the Solstice Launcher and select the name service, if not done already.**  
See “How to Start Host Manager” on page 81 for more information.
2. **Select Add from the Edit menu on the Host Manager main window.**  
The Add window is displayed.
3. **Fill in the system information, selecting Solaris Diskless as the system type.**  
The system information includes all the fields from the host name through the timezone. If you need information to complete a field, click on the Help button to see field definitions for this window.
4. **Select a File Server.**  
The File Server defaults to the current host. Select Other from the Install Server menu to specify another host as the install server.
5. **Select the client’s architecture type and the OS release from the OS Release menu.**  
The architecture type must match the diskless client’s architecture and the OS release should match the Solaris release you want diskless client to run.
6. **Identify the system’s root path, swap path, and swap size.**
7. **Set the system’s root password.**
8. **Click on OK on the Add window.**

**9. Select Save Changes from the File menu to add support for the diskless client.**

The diskless client is displayed in the Host Manager main window. It takes several minutes to add the diskless client support, particularly to create the system's root and swap areas and apply any applicable patches with the `admclientpatch(1M)` command.



---

**Caution** - For the diskless client to work properly, it needs root access to its `/export/root` directory. If Host Manager displays a message that the `/export` directory is already shared and has different share options than required, you need to allow root access to the client root area before the diskless client will function properly. The access mode for the client root is normally `rw=clientname, root=clientname`. If Host Manager displays a message that the `/usr` directory is already shared, it is because it tried to share `/usr` read-only. If you have it shared with read-write permissions, it is okay and you do not have to make any modifications.

---

**10. Boot the diskless client from the network.**

Refer to Chapter 12, for detailed information on how to boot a diskless client manually or how to set up a diskless client to automatically boot from the network.

**11. Provide the following system configuration information for the diskless client during the initial boot process, if prompted.**

- Geographic region
- Time zone
- Date and time

**12. Create a root password when prompted, if not set at the client creation time.**

## Example of a Completed Add Window for a Diskless Client

The screenshot shows a dialog box titled "Host Manager: Add" with the following fields and values:

- Host Name: orion
- IP Address: 129.152.221.66
- Ethernet Address: 8:0:20:d:63:b2
- System Type: Solaris Diskless
- Timezone Region: United States
- Timezone: Mountain
- File Server: loma
- OS Release: sparc sun4c Solaris 2.5
- Root Path: /export/root
- Swap Path: /export/swap
- Swap Size: 32 megabytes
- Terminal Type: sun

Below the fields is a button labeled "Root Password...". At the bottom of the dialog are five buttons: "OK", "Apply", "Reset", "Cancel", and "Help".

## Example of a Command-Line Equivalent for Adding Diskless Client

The following command is equivalent to using Host Manager to add support for a diskless client.

```
% admhostadd -i 129.152.221.66 -e 8:0:20:d:63:b2 -x type=DISKLESS -x tz=US/Mountain
-x fileserv=pluto -x os=sparc.sun4c.Solaris_2.5 -x passwd=abc -x root=/export/root\
-x swap=/export/swap -x swapsize=24 orion
```

In this command,

<code>-i 129.152.221.66</code>	Specifies the IP address for the diskless client.
<code>-e 8:0:20:d:63:b2</code>	Specifies the Ethernet address for the diskless client.
<code>-x type=DISKLESS</code>	Specifies the type of the system.
<code>-x tz=US/Mountain</code>	Specifies the system's timezone.
<code>-x fileserv=pluto</code>	Specifies the name of the OS server for the diskless client.
<code>-x os= sparc.sun4c.Solaris_2.5</code>	Specifies platform, kernel architecture, and software release of the diskless client.
<code>-x passwd=abc</code>	Specifies the root password.
<code>-x root=/export/root</code>	Specifies the root path of the diskless client.
<code>-x swap=/export/swap</code>	Specifies the directory where the swap file will be created.
<code>-x swapsize=24</code>	Specifies the size the swap file.
<code>orion</code>	Specifies the name of the diskless client.

## ▼ How to Add Support for a JavaStation Client

The high-level steps in this procedure are:

- Add system information about the JavaStation client.
- Boot the JavaStation client.

---

**Note** - This procedure assumes the system providing the services (the file server) has already been configured as a Java OS server.

---

- 1. Start Host Manager from the Solstice Launcher and select the name service, if not done already.**  
See “How to Start Host Manager” on page 81 for more information.
- 2. Select Add from the Edit menu on the Host Manager main window.**  
The Add window is displayed.
- 3. Fill in the system information, selecting JavaStation as the system type.**  
The system information includes all the fields from the host name through the timezone. If you need information to complete a field, click on the Help button to see field definitions for this window.
- 4. Select a File Server.**  
The File Server defaults to the current host. Select Other from the Install Server menu to specify another host as the install server.
- 5. Select the sparc sun4m JavaOS 1.0 OS Release.**  
In order to select this OS release you must have JavaOS services installed on your server. Refer to “How to Add JavaOS Services to an OS Server” on page 97 for more information about adding JavaOS services.
- 6. Identify the system’s root path.**
- 7. Click on OK on the Add window.**



## Example of a Completed Add Window for a JavaStation Client

The screenshot shows a dialog box titled "Host Manager: Add". It contains several fields for configuring a client:

- Host Name: coffee
- IP Address: 129.152.228.71
- Ethernet Address: 0:aa:0bf:db:rd
- System Type: JavaStation
- Timezone Region: United States
- Timezone: Mountain
- File Server: admin-7
- OS Release: sparc sun4m JavaOS 1.0
- Root Path: /export/root

At the bottom of the dialog box are five buttons: OK, Apply, Reset, Cancel, and Help.

### ▼ How to Add Support for a Dataless Client

The high-level steps in this procedure are:

- Add system information about the dataless client.
- Select OS services for the dataless client.
- (Optional) Set up remote install capabilities for the dataless client.
- (Optional) Boot and install the dataless client.

---

**Note** - This procedure assumes the system providing the services (the file server) has already been configured as an OS server. If you are running an operating system later than Solaris 2.5.1, dataless clients are no longer supported.

---

1. **Start Host Manager from the Solstice Launcher and select the name service, if not done already.**

See “How to Start Host Manager” on page 81 for more information.

2. **Select Add from the Edit menu on the Host Manager main window.**

The Add window is displayed.

3. **Fill in the system information, selecting Solaris Dataless as the system type.**

The system information includes all the fields from the host name through the time zone. If you need information to complete a field, click on the Help button to see field definitions for this window.

4. **Select a File Server.**

The File Server defaults to the current host. Select Other from the Install Server menu to specify another host as the install server.

5. **Select the system’s architecture type and OS release from OS Release menu.**

The architecture type must match the dataless client’s architecture, and the OS release should match the Solaris release you want the dataless client to run.

6. **If you want to set up remote install capabilities for the system, continue to Step 7 on page 106. If not, skip to Step 11 on page 107.**

7. **Click on Enable Remote Install.**

---

**Note** - The remote install button enables the client to boot from the specified install server.

---

8. **Select an Install Server.**

The Install Server defaults to the current host. Select Other from the Install Server menu to specify another host as the install server.

9. **Click on Set Path to identify the path to the Solaris CD image on the install server.**

If the install server is a remote system, note that it must be minimally set up as a managed system.

---

**Note** - The path to the Solaris CD image must be the same release that you specified in the OS Release menu.

---

If You Are Using ...	And ...	Then Enter the Path ...
The Solaris CD as the Solaris CD image	The Solaris CD is managed by Volume Management	/cdrom/cdrom0 or /cdrom/cdrom0/s0 or /cdrom/cdrom0/s2
	The Solaris CD is not managed by Volume Management	Where you mounted the Solaris CD
A copy of the Solaris CD on the Install Server's hard disk (by using setup_install_server)		Where you specified setup_install_server to copy the Solaris CD

**10. If necessary, specify a boot server and/or profile server.**

To specify another server other than the default, select Other from the menu. Select a Profile Server from the Profile Server pull-down menu. You must also specify a path to the boot software on the boot server or the custom JumpStart directory on the profile server.

To set up the other components of a custom JumpStart installation and preconfiguring network and system information, see *Solaris Advanced Installation Guide* or *x86: Installing Solaris Software*.

**11. Click on OK on the Add window.**

**12. Select Save Changes from the File menu to add support for the dataless client.**

The dataless client is displayed in the Host Manager main window.



**Caution** - For the dataless client to work properly, it needs root access to its /export/root directory. If Host Manager displays a message that the /export directory is already shared and has different share options than required, you need to allow root access to the client root area before the dataless client will function properly. The access mode for the client root is normally `rw=clientname, root=clientname`. If Host Manager displays a message that the /usr directory is already shared, it is because it tried to share /usr read-only. If you have it shared with read-write permissions, it is okay and you do not have to make any modifications.

**13. (Optional) Boot and install the dataless client.**

For more information about booting and installing, see *Solaris Advanced Installation Guide* or *x86: Installing Solaris Software*.

## Example of a Completed Add Window for a Dataless Client

The screenshot shows a dialog box titled "Host Manager: Add" with the following fields and values:

- Host Name: neptune
- IP Address: 129.152.225.2
- Ethernet Address: 8:0:20:7:e0:26
- System Type: Solaris Dataless
- Timezone Region: United States
- Timezone: Mountain
- File Server: loma
- OS Release: sparc sun4c Solaris 2.5
- Remote Install:  Enable Remote Install
- Install Server: calite
- Boot Server: none
- Profile Server: none

Buttons at the bottom: OK, Apply, Reset, Cancel, Help.

## Example of a Command-Line Equivalent for Adding Dataless Client

The following command is equivalent to using Host Manager to add support for a dataless client.

```
% admhostadd -i 129.152.225.2 -e 8:0:20:7:e0:26 -x type=DATALESS -x tz=US/Mountain
-x fileserv=pluto -x os=sparc.sun4c.Solaris_2.5 neptune
```

In this command,

<code>-i 129.152.225.2</code>	Specifies the IP address for the dataless client.
<code>-e 8:0:20:7:e0:26</code>	Specifies the Ethernet address for the dataless client.
<code>-x type=DATALESS</code>	Specifies the type of the system.
<code>-x tz=US/Mountain</code>	Specifies the system's timezone.
<code>-x fileserv=pluto</code>	Specifies the name of the OS server for the dataless client.
<code>-x os= sparc.sun4c.Solaris_2.5</code>	Specifies platform, kernel architecture, and software release of the dataless client.
<code>neptune</code>	Specifies the name of the system.

---

**Note** - Operating systems greater than Solaris 2.5.1 no longer support dataless clients.

---

## ▼ How to Add a Multihomed Host

- 1. Start Host Manager from the Solstice Launcher and select the name service, if not done already.**  
See "How to Start Host Manager" on page 81 for more information.
- 2. Select Add from the Edit menu on the Host Manager main window.**  
The Add window is displayed.
- 3. Enter the name of the host you wish to add another IP address to in the Host Name field provided and press the tab key to advance to the next field.**  
The Host Manager: Add window condenses to a smaller window where the only field you can change is the IP Address field and System Type: indicates that it is a Multihomed host.
- 4. Enter the additional IP Address and click on the OK button.**  
You will see that in the Host Manager main window, the host that you made a multihomed host is listed twice.

5. Choose the **Save Changes** option from the **File** menu.

Example of a Completed Add Window for a Multihomed Host

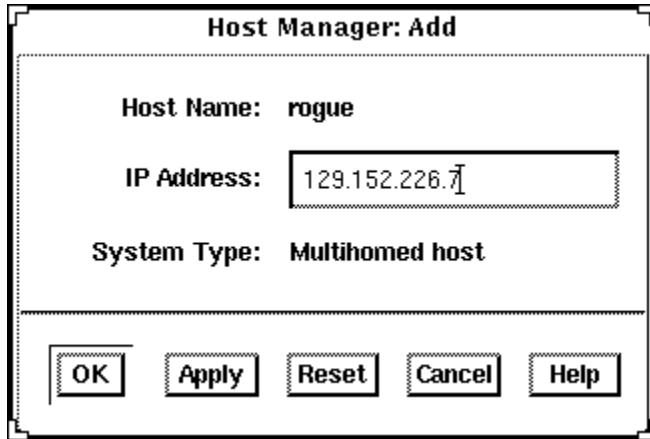

**Host Manager: Add**

Host Name: **rogue**

IP Address:

System Type: **Multihomed host**

---

## Maintaining Server and Client Support

TABLE 6-9 Task Map: Maintaining Server and Client Support

Activity	Description	For Instructions, Go To
Modify Support for a System	Modify support for a system by choosing <b>Modify</b> from the Host Manager's Edit menu.	"How to Modify Support for a System" on page 111
Delete Support for a System	Delete support for a system by choosing <b>Delete</b> from the Host Manager's Edit menu.	"How to Delete Support for a System" on page 111

## ▼ How to Modify Support for a System

1. **Start Host Manager from the Solstice Launcher and select the name service, if not done already.**  
See “How to Start Host Manager” on page 81 for more information.
2. **Select a system entry to modify from the Host Manager main window.**
3. **Choose Modify from the Edit menu.**  
The Modify window contains the selected system entry.
4. **Modify support for the system.**  
If you need information to change a field, click on the Help button to see field definitions for this window.
5. **Click on OK on the Modify window.**
6. **Select Save Changes from the File menu to modify support for the system.**

### Command-Line Equivalent for Modifying Support for a System

You can also use the `admhostmod` command to modify support for a system.

## ▼ How to Delete Support for a System

1. **Start Host Manager from the Solstice Launcher and select the name service, if not done already.**  
See “How to Start Host Manager” on page 81 for more information.
2. **Select a system entry to delete from the Host Manager main window.**
3. **Select Delete from the Edit menu.**  
A window is displayed asking you to confirm the deletion.
4. **Click on OK.**
5. **Select Save Changes from the File menu to delete support for the system.**  
The system entry is deleted from the Host Manager main window.

## Command-Line Equivalent for Deleting Support for a System

You can also use the `admhostdel` command to delete support for a system.

---

# Using the Command-Line Equivalents to Automate Setup Tasks

Using the Host Manager command-line equivalents allows you to automate many of the setup tasks associated with creating new diskless and AutoClient systems. This automation is similar to what can be done when using the JumpStart product to install Solaris on standalone systems. By writing your own shell scripts and using the command-line equivalents, you can automatically customize the client environment in one operation.

## Command-Line Equivalent Automation Example

The following example shows how to use the command-line equivalents to set up an OS server, add OS services, and add a diskless client to that server. The server's name is `rogue`, and the diskless client is `venus`.

---

**Note** - For additional command-line examples, see the command-line equivalent section at the end of most of the procedures in this chapter.

---

### 1. Convert a standalone system to an OS server.

```
% admhostmod -x type=os_server rogue
```

### 2. Add OS services to the OS server.

#### a. This example adds the Solaris 2.5 End User Cluster OS services for the Sun4m kernel architecture to `rogue`.

The Solaris CD image is on a mounted CD on a remote system named `jupiter`. Note that the remote system must be minimally set up as a managed system.

```
% admhostmod -x mediapath=jupiter:/cdrom/cdrom0/s0 \  
-x platform=sparc.sun4m.Solaris_2.5 -x
```

(continued)



```
cluster=SUNWCuser \ rogue
```

**b. This example adds the Solaris 2.5.1 All Cluster OS services for the Sun4m kernel architecture to `rogue`.**

The Solaris CD image has been copied to hard disk on a remote system, `saturn`, and the automounter is used to access it. Note that the remote system must be minimally set up as a managed system.

```
% admhostmod -x mediapath=rogue:/net/saturn/export/Solaris_CD \
-x platform=sparc.sun4m.Solaris_2.5.1 -x
cluster=SUNWCall \
rogue
```

**3. Add the diskless client.**

This example adds a sun4m, Solaris 2.5.1 diskless client named `venus` to the server `rogue`.

```
% admhostadd -i 129.152.225.2 -e 8:0:20:b:40:e9 \
-x type=diskless -x fileserv=rogue \
-x os=sparc.sun4m.Solaris_2.5.1 \
-x swapsize=40 -x venus
```

You could use a similar version of this command in a shell script with additional operations to customize the diskless client's root as part of setting up the client. The script could be parameterized to accept the IP address, Ethernet address, and host name.



## Managing Users With User Manager and Group Manager

---

This chapter describes how to manage user accounts using two applications within the Solstice AdminSuite software:

- Group Manager, a graphical user interface for managing group information
- User Manager, a graphical user interface used to manage user account information

This is a list of the step-by-step instructions in this chapter.

- “How to Start Group Manager” on page 119
- “How to Add a Group” on page 120
- “How to Start User Manager” on page 122
- “How to Set Up User Account Defaults” on page 123
- “How to Add a New User Account” on page 124
- “How to Copy an Existing User Account” on page 127
- “How to Modify a Group” on page 129
- “How to Delete a Group” on page 131
- “How to Modify a User Account” on page 131
- “How to Delete a User Account” on page 133

---

# Command-Line Equivalents of Group Manager

Table 7-1 lists the commands that provide the same functionality as Group Manager and can be used without running an X Window System. Many of the Group Manager procedures in this chapter provide corresponding examples using the command-line equivalents.

**TABLE 7-1** Command-Line Equivalents of Group Manager

<b>Command</b>	<b>Description</b>
<code>admgroupadd</code>	Adds a new group and members (if specified) to the group
<code>admgroupmod</code>	Modifies an existing group
<code>admgroupdel</code>	Deletes an existing group
<code>admgroups</code>	Lists the existing groups in the selected name service

---

# Files Modified by Group Manager

Table 7-2 lists the files Group Manager modifies depending on what name service you selected.

**TABLE 7-2** Files Modified by Group Manager

<b>If the Name Service You Selected Is ...</b>	<b>Then Group Manager Modifies The ...</b>
NIS or NIS+	Name service's group database
None	<code>/etc/group</code> file

---

# Command-Line Equivalents of User Manager

Table 7-3 lists the commands that provide the same functionality as User Manager and can be used without running OpenWindows or Motif CDE. Many of the User Manager procedures in this chapter provide corresponding examples using the command-line equivalents.

**TABLE 7-3** Command-Line Equivalents of User Manager

Command	Description
<code>admuseradd</code>	Adds a new user account. Unlike the User Manager, you cannot copy a user account with this command.
<code>admusermod</code>	Modifies an existing user account.
<code>admuserdel</code>	Deletes an existing user account.
<code>admuserls</code>	Lists the existing user accounts in the selected name service.

---

# Files Modified by User Manager

Table 7-4 describes the system files that are modified by User Manager.

**TABLE 7-4** Files Modified by User Manager

System File	Where Modified	Description
<code>auto_home</code>	<code>/etc</code> or NIS+	An indirect automounter database containing entries that enable client systems to mount their home directories automatically
<code>auto.home</code>	NIS	An indirect automounter database containing entries that enable client systems to mount their home directories automatically

**TABLE 7-4** Files Modified by User Manager *(continued)*

System File	Where Modified	Description
group	/etc, NIS, or NIS+	A database containing UNIX group entries recognized on the local system or in a name service
passwd	/etc, NIS, or NIS+	A database containing user account entries such as user name, user ID, group ID, and home directory
shadow	/etc (shadow information is stored in the passwd file when NIS or NIS+ is used)	A database containing user password entries in encrypted form and password aging information
/var/mail/\$USER	Mail server	A file used to store the user's email
/etc/aliases	Mail server	A file used to store mail addresses for the user
cred.org_dir	NIS+	A NIS+ table used to store the user's DES and LOCAL credentials

## Setting Up User Accounts

**TABLE 7-5** Task Map: Setting Up User Accounts

Activity	Description	For Instructions, Go To
Add Groups	Optional. To help administer users, add groups by choosing Add from the Group Manager's Edit menu. This is usually a one-time task.	"How to Add a Group" on page 120
Set User Account Defaults	Optional. Before you add several user accounts, set up defaults for the User Manager by choosing Set Defaults from the User Manager's Edit menu. Setting up defaults can increase the consistency and efficiency of adding user accounts.	"How to Set Up User Account Defaults" on page 123

TABLE 7-5 Task Map: Setting Up User Accounts (continued)

Activity	Description	For Instructions, Go To
Add a User Account	Add a New User Account Add a user account by choosing Add from the User Manager's Edit menu.	"How to Add a New User Account" on page 124
	Copy an Existing User Account Copy an existing user account by choosing Copy from the User Manager's Edit menu. This is useful if you need to add a user account that is similar to an existing user account.	"How to Copy an Existing User Account" on page 127

## ▼ How to Start Group Manager

1. Verify that the prerequisites described in Chapter 1, are met.
2. Start the Solstice Launcher.

```
$ solstice &
```

The Solstice Launcher is displayed.

3. Click on the Group Manager icon.



### Group Manager

The Load window is displayed.

4. Select the name service used in your network.
5. Check that the domain or host name is correct.  
If not, type the name of the domain or host you need to access.
6. Click on OK.  
The Group Manager main window is displayed.

## Example of the Group Manager Main Window

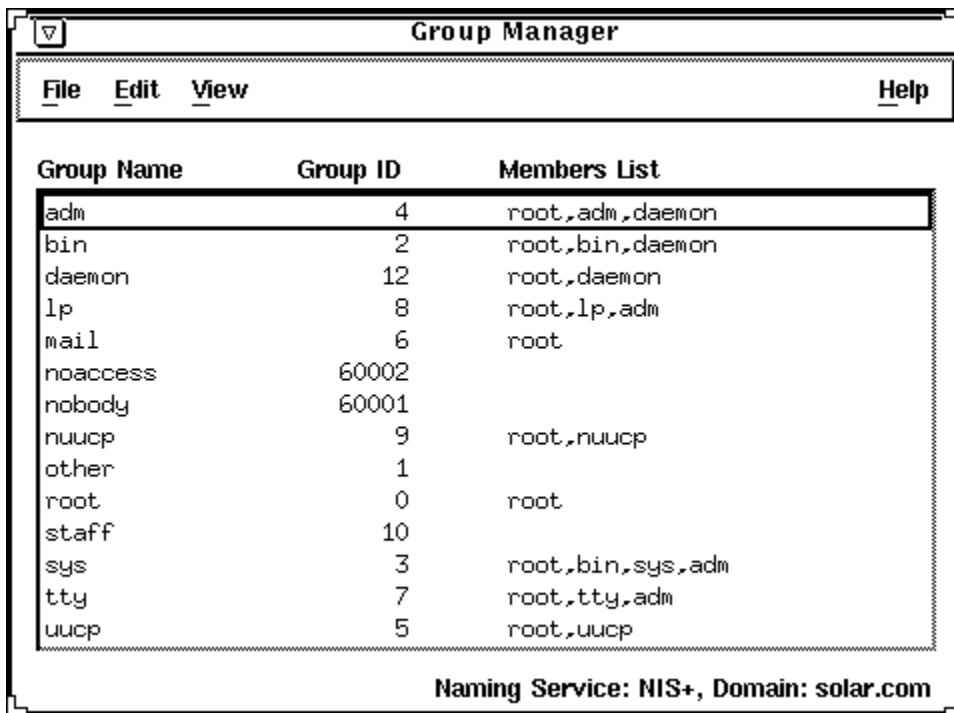

### ▼ How to Add a Group

- 1. Start Group Manager from the Solstice Launcher and select the name service, if not done already.**  
See "How to Start Group Manager" on page 119 for more information.
- 2. Choose Add from the Edit menu on the Group Manager main window.**  
The Add window is displayed. If you need information to complete a field, click on the Help button to see field definitions for this window.
- 3. Type the name of the new group in the Group Name text box.**
- 4. Type the group ID for the new group in the Group ID text box.**  
The group ID should be unique.
- 5. (Optional) Type user names in the Members List text box.**  
The list of users will be added to the group. User names must be separated by commas.



6. (Optional) Select the Password button to set the group password.

Enter the group password and then verify the password in the fields provided in the Password dialog box.

7. Click on OK.

The list of groups displayed in the Group Manager main window is updated to include the new group.

### Example of a Completed Add Window

The following example adds a group named `users` that has a group ID of 100.

The screenshot shows a dialog box titled "Group Manager: Add". It contains the following fields and controls:

- Group Name:** A text box containing the text "users".
- Group ID:** A text box containing the text "100".
- Members List:** A text box containing the text "bert,ernie,osca".
- Password...:** A button to open a password dialog.
- Buttons:** A row of five buttons: "OK", "Apply", "Reset", "Cancel", and "Help".

### Example of a Command-Line Equivalent for Adding a Group

The following example is the equivalent of using Group Manager to add a group named `users` that has a group ID of 100.

D

```
# admgroupadd -g 100 -x pass=abc users
```

## ▼ How to Start User Manager

1. **Verify that the prerequisites described in Chapter 1, are met.**
2. **Start the Solstice Launcher.**

```
$ solstice &
```

The Solstice Launcher is displayed.

3. **Click on the User Manager icon from the Solstice Launcher.**



### **User Manager**

The Load window is displayed.

4. **Select the name service used in your network.**
5. **Check that the domain or host name is correct.**  
If not, type the name of the domain or host you need to access.
6. **Click on OK.**  
The User Manager main window is displayed.

## Example of the User Manager Main Window

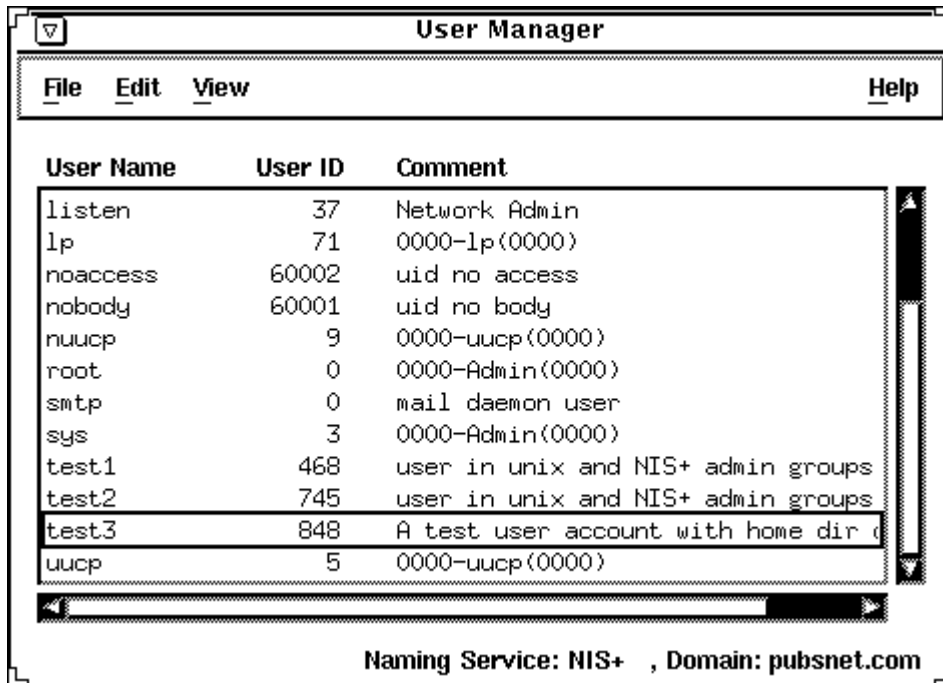

### ▼ How to Set Up User Account Defaults

1. **Start User Manager from the Solstice Launcher and select the name service, if not done already.**

See "How to Start User Manager" on page 122 for more information.

2. **Choose Set Defaults from the Edit menu.**  
The Set Add Defaults window is displayed.

3. **Fill in the Set Add Defaults window.**

The defaults you select will be the initial defaults values in the Add window. If you need information to complete a field, click on the Help button to see field definitions for this window.

You can set the following defaults:

- Primary and Secondary Groups
- Login Shell
- Password Policy
- Creating a Home Directory
- Home Directory Server

- Skeleton Path (Path to User Initialization Files)
- Using AutoFS (AutoHome Setup)
- Permissions in Home Directory
- Mail Server

**4. Click on OK.**

## Command-Line Equivalent for Setting Up User Account Defaults

You can use the `admuseradd` command with the `-D` option to set up user account defaults from the command line.

### ▼ How to Add a New User Account

**1. Start User Manager from the Solstice Launcher and select the name service, if not done already.**

See “How to Start User Manager” on page 122.

**2. Choose Add from the Edit menu.**

The Add window is displayed.

**3. Fill in the Add window.**

If you need information to complete a field, click on the Help button to see field definitions for this window.

**4. Click on OK.**

The list of user accounts displayed in the User Manager main window is updated to include the new user account.

### Example of a Completed Add Window

The server where the home directory is located.

The path (on the system running User Manager) from which to copy user initialization files into the user's home directory. You can also specify an auto-mounted path to user initialization files on another system.

Any selected scripts are run on this server when the User is added. Refer to the following page for an example of the Script Selection window.

## Example of the Script Selection Window

The following screen shows an example of the Script Selection window; in order for scripts to be run from this window, the scripts must be located in the `/opt/SUNWadmd/Scripts` directory.

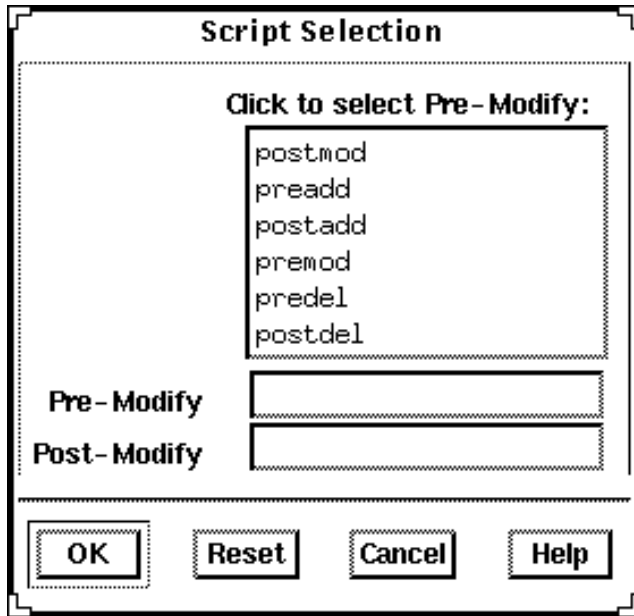

## Example of a Command-Line Equivalent for Adding a User

The following command is the equivalent to adding a user with User Manager.

```
# admuseradd -u 101 -g users -c ``Kryten Series 4000`` -s /bin/csh -k /etc/skel -x
preadd=preaddscript -x postadd=postaddscript -x pw=NORM \
-x pwwarn=1 -d /export/home/kryten -m -x autohome=Y -x serv=jupiter kryten
```

In this command,

-u 101	Specifies the user ID, in this case 101.
-g users	Specifies the user's primary group, in this case a group named users.
-c ``Kryten Series 4000``	Specifies a comment for the user account.
-s /bin/csh	Specifies the default shell environment, in this case the C shell.
-k /etc/skel	Specifies a directory containing skeleton information, such as <code>.cshrc</code> , that will be copied into the user's home directory.

<code>-x preadd=preaddscript</code>	Specifies the user created script ( <code>preaddscript</code> ) located in <code>/opt/SUNWadmd/Scripts</code> that is designated to run before the user is added.
<code>-x postadd=postaddscript</code>	Specifies the user created script ( <code>postaddscript</code> ) located in <code>/opt/SUNWadmd/Scripts</code> that is designated to run after the user is added.
<code>-x pw=NORM</code>	Specifies the initial password type, in this case normal.
<code>-x pwwarn=1</code>	Specifies the number of days that the user will be warned about password expiration.
<code>-d /export/home/kryten</code>	Specifies the name of the home directory.
<code>-m</code>	Creates the new user's home directory (as specified with the <code>-d</code> option) if it does not already exist.
<code>-x autohome=Y</code>	Specifies whether the home directory should be set up to be automounted.
<code>-x serv=jupiter</code>	Specifies the name of the server where the home directory will reside.
<code>kryten</code>	Specifies the name of the system.

## ▼ How to Copy an Existing User Account

1. **Start User Manager from the Solstice Launcher and select the name service, if not done already.**

See "How to Start User Manager" on page 122.

2. **Select a user account entry to copy from the main window.**

3. **Choose Copy from the Edit menu.**

The Copy window is displayed with the following fields copied from the selected user account:

- Primary Group
- Secondary Groups
- Comment
- Login Shell
- Path
- Server

- Skeleton Path

**4. Fill in the fields in the Copy window.**

If you need information to complete a field, click on the Help button to see field definitions for this window.

**5. Click on OK.**

The list of user accounts displayed in the User Manager main window is updated to include the new user account.

---

**Note** - There is no command line equivalent for copying an existing user account.

---



---

## Maintaining User Accounts

**TABLE 7-6** Task Map: Maintaining User Accounts

Activity	Description	For Instructions, Go To
Modify a Group	Modify a group's name or the users in a group by choosing Modify from the Group Manager's Edit menu.	"How to Modify a Group" on page 129
Delete a Group	Delete a group by choosing Delete from the Group Manager's Edit menu.	"How to Delete a Group" on page 131
Modify a User Account	If a user account needs to be changed, modify the user account by choosing Modify from the User Manager's Edit menu.	"How to Modify a User Account" on page 131



TABLE 7-6 Task Map: Maintaining User Accounts (continued)

Activity	Description	For Instructions, Go To
Delete a User Account	Delete a user account by choosing Modify from the User Manager's Edit menu.	"How to Delete a User Account" on page 133

## ▼ How to Modify a Group

1. **Start Group Manager from the Solstice Launcher and select the name service, if not done already.**  
See "How to Start Group Manager" on page 119 for more information.
2. **Select the group entry to modify from the Group Manager main window.**
3. **Choose Modify from the Edit menu.**  
The Modify window is displayed containing the selected group entry.
4. **Either modify the group's name or the users in the group.**  
User names must be separated by commas. If you need information to complete a field, click on the Help button to see field definitions for this window.
5. **Modify the group's password by selecting the Password button.**  
Enter the group password and then verify it in the fields provided in the Password dialog box.
6. **Click on OK.**  
The group information displayed in the main window is updated.

## Example of a Completed Modify Window

**Group Manager: Modify**

Group Name:

Group ID: 10

Members List:

## Example of a Command-Line Equivalent for Modifying a Group

The following command is the equivalent to modifying the member list in a group with Group Manager.

```
# admgroupmod -g 10 -x members=r2d2,holly,kryten -x passwd=abc  
groupname
```

In this command,

-g 10	Specifies the number of group, in this case 10.
-x members= r2d2,holly,kryten	Specifies the users who belong to group 10: r2d2, holly, and kryten.
-x passwd=abc	Specifies the group password: abc
groupname	Specifies the name given to the group

## ▼ How to Delete a Group

1. **Start Group Manager from the Solstice Launcher and select the name service, if not done already.**  
See “How to Start Group Manager” on page 119 for more information.
2. **Select the group entry you want to delete from the Group Manager main window.**
3. **Choose Delete from the Edit menu.**  
A window is displayed asking you to confirm the deletion.
4. **Click on OK.**  
The group entry is deleted from the Group Manager main window.

### Command-Line Equivalent for Deleting a Group

You can also use the `admgroupdel` command to delete a group.

## ▼ How to Modify a User Account

1. **Start User Manager from the Solstice Launcher and select the name service, if not done already.**  
See “How to Start User Manager” on page 122 for more information.
2. **Select the user account entry to modify from the User Manager main window.**
3. **Choose Modify from the Edit menu.**  
The Modify window is displayed containing the selected user account entry.
4. **Modify the user account.**  
If you need information to complete a field, click on the Help button to see field definitions for this window.
5. **Click on OK.**

### Verification

Double-click on the modified user account entry in the User Manager main window to verify that the modifications were made. Click on Cancel to close the window without making any modifications.

## Example of a Completed Modify Window

The following example sets the user lacey to be a member of the lp secondary group.

**User Manager: Modify**

**USER IDENTITY**

User Name:

User ID: 30588

Primary Group:

Secondary Groups:

Comment:

Login Shell:

**ACCOUNT SECURITY**

Password:

Min Change:  days

Max Change:  days

Max Inactive:  days

Expiration Date:

Warning:  days

**HOME DIRECTORY**

Path:

Server: loma

AutoHome Setup:

**MISCELLANEOUS**

Script Features:  Enable Scripts

Mail Server:

## Example of the Script Selection Window

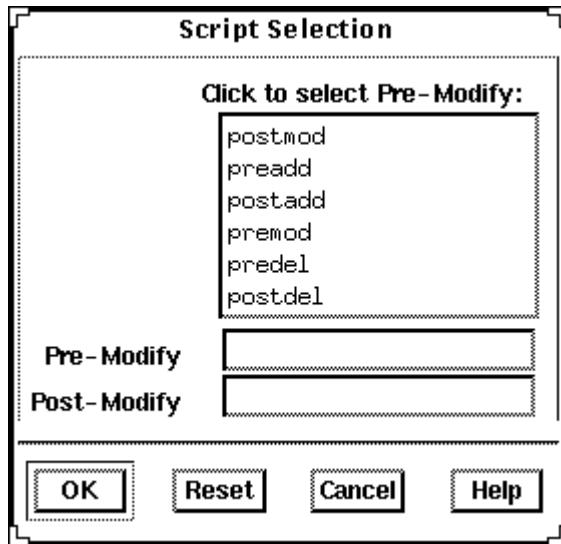

## Example of a Command-Line Equivalent for Modifying a User Account

The following command is the equivalent to modifying a user account with User Manager. In this case, the command sets the user `rimmer` to be a member of the `lp` secondary group.

```
# admusermod -G lp rimmer
```

## ▼ How to Delete a User Account

1. **Start User Manager from the Solstice Launcher and select the name service, if not done already.**  
See “How to Start User Manager” on page 122 for more information.
2. **Select the user account entry to remove from the main window.**
3. **Choose Delete from the Edit menu.**  
The Delete window is displayed to confirm the removal of the user account.
4. **(Optional) Click on the check box to enable scripts and then click on the ellipsis button to select the script to be enabled from the Script Selection dialog box.**  
The script can be enabled to run before or after the user account is deleted.

---

**Note** - In order to run the user supplied scripts, the scripts must be located in the /opt/SUNWadmd/Scripts directory.

---

5. (Optional) Click on the check box to delete the user's home directory and its contents.
6. (Optional) Click on the check box to delete the user's mailbox and its contents.
7. Click on OK when you are ready to delete the user account.  
The user account entry is deleted from the User Manager main window.

### Example of the Delete Window

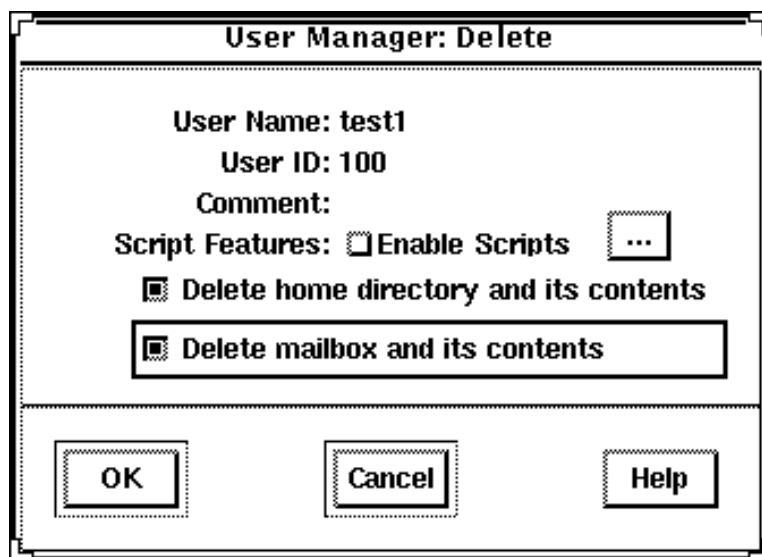

### Example of a Command-Line Equivalent for Deleting a User Account

The following command is the equivalent of deleting a user account with User Manager.

```
# admuserdel -r -x serv=lorna -x predel=predelscript -x
postdel=postdelscript test1
```

In this command,

-r	Specifies that the contents of the user's home directory be removed.
-x serv=lorna	Specifies the name of the server where the home directory resides.
-x predel=predelscript	Specifies the name of the script to run before the user is deleted.
-x postdel=postdelscript	Specifies the name of the script to run after the user is deleted.
test1	Specifies the name of the user account.

---

**Note** - The scripts are user created scripts that are located in the /opt/SUNWadmd/Scripts directory.

---





## Managing Terminals and Modems With Serial Port Manager

---

This chapter describes how to set up and maintain modems and terminals by using the Solstice Serial Port Manager and its corresponding command-line equivalents. This is a list of the step-by-step instructions in this chapter.

- “How to Start Serial Port Manager” on page 142
- “How to Configure Multiple Ports Using Serial Port Manager” on page 143
- “How to Add a Terminal” on page 143
- “How to Add a Modem” on page 144
- “How to Initialize a Port Without Configuring” on page 147
- “How to Disable a Port” on page 148
- “How to Delete a Port Service” on page 148

Serial Port Manager configures the serial port software to work with terminals and modems by calling the `pmadm` command and supplying the appropriate information. It features:

- Displays of serial port information
- Templates for common terminal and modem configurations
- Multiple port setup, modification, or deletion

# Serial Port Manager Features

The Serial Port Manager enables you to configure or remove terminals and modems used with your serial ports. This tool also enables you to configure multiple ports at the same time.

The Serial Port Manager consists primarily of two windows: the Serial Port Manager main window and the Modify window.

The Serial Port Manager main window displays the serial ports for the system that you are currently logged managing.

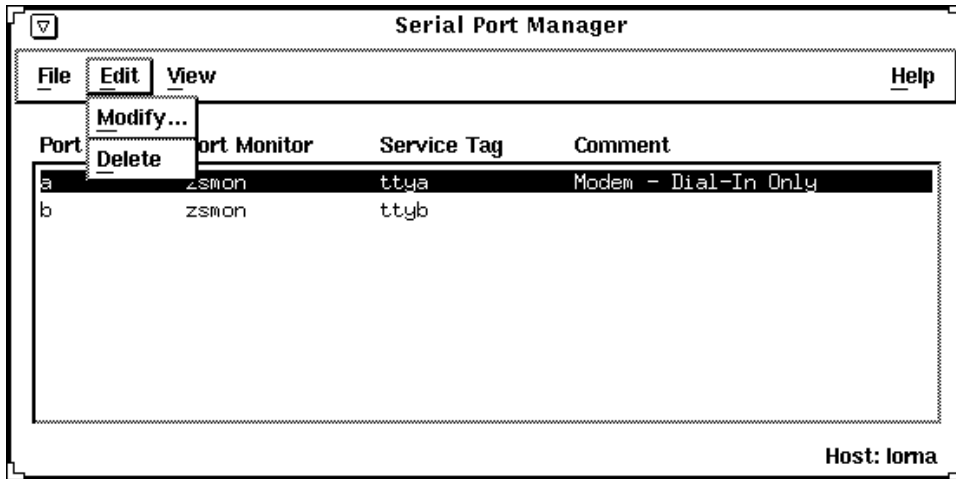

In this window, three pull-down menus enable you to:

- Select the port that you wish to modify
- Delete modems and terminals
- View serial ports for different hosts

The three pull-down menus consist of the following:

Pull-down Menu	Options	Description
File	Exit	Closes the Serial Port Manager tool
Edit	Modify	Opens the Serial Port Manager: Modify window

Pull-down Menu	Options	Description
	Delete	Removes the port monitor and service tag configuration for the selected port
View	Host	Brings up the Host window, which enables you to select from a list of available hosts

The option that is most commonly used is the Modify option in the Edit pull-down menu. This option opens the Modify window.

In this window, you have many options to choose from, including templates for commonly used terminal and modem configurations. The templates can be viewed by selecting the Template button, which enables you to choose one of the following template options:

- Terminal - Hardwired
- Modem - Dial in Only
- Modem - Dial out Only
- Modem - Bidirectional
- Initialize Only - No Connection

**Serial Port Manager: Modify**

Template:       Detail:

---

Port: a      Baud Rate:

Service Enable      Terminal Type:

---

Options:  Initialize Only      Login Prompt:   
 Bidirectional      Comment:   
 Software Carrier      Service Tag:   
Port Monitor Tag:

---

Expert Options:  Create utmp Entry      Service:   
 Connect on Carrier      Streams Modules:   
Timeout (secs):

---

You can select the desired option level using one of the Detail buttons described in Table 8-1. Each button displays a different level of options, as shown in the previous screen display. (Each level is separated by a thin line.)

**TABLE 8-1** Serial Port Manager Detail Options

<b>Detail</b>	<b>Option</b>	<b>Description</b>
Basic	Service Enable	Button that allows you to enable (button selected) or disable (button de-selected) the associated port.
	Baud Rate	Button that allows you to select the baud rate of your terminal or modem. You can either choose one of the listed baud rates or enter a different baud rate using the other option.
	Terminal Type	Text entry field that allows you to specify the type of terminal that will be connected to the serial port.
More	Initialize Only	Button that specifies that the port software is initialized, but not configured.
	Bidirectional	Button that specifies that the port line is used in both directions.
	Software Carrier	Button that specifies that the software carrier detection feature is used. If this option is not checked, the hardware carrier detection signal is used.
	Login Prompt	Text entry field that allows you to change the login prompt.
	Comment	Text entry field that allows you to type any comments to clarify the type of port the serial port is configured to be; by default, the Comment field will display the name of the serial port template that you have selected.
	Service Tag	tty tag entry that corresponds to the selected port.
	Port Monitor Tag	Button that allows you to select the type of monitor associated with this port; you can either choose from the list or choose the Other option and then enter the monitor type.
Expert	Create utmp Entry	Button that when selected, specifies that a utmp entry is created upon login. This item must be checked if a login service is used.

**TABLE 8-1** Serial Port Manager Detail Options *(continued)*

Detail	Option	Description
Expert (continued)	Connect on Carrier	Button that when selected, specifies that a port's associate service is invoked immediately when a connect indication is received.
	Service	Text entry field that specifies the program that is run upon connection.
	Streams Modules	Text entry field that shows the Streams modules that are pushed before the service is started.
	Timeout (secs)	Button that allows you to chose the amount of seconds before the connection times out.

## Command-Line Equivalents of Serial Port Manager

Table 8-2 lists the commands that provide the same functionality as Serial Port Manager and can be used without running OpenWindows or Motif CDE. Many of the Serial Port Manager procedures in this chapter provide corresponding examples using the command-line equivalents.

**TABLE 8-2** Command-Line Equivalents of Serial Port Manager

Command	Description
<code>admserialmod</code>	Modifies a serial port service for a terminal or modem
<code>admserialdel</code>	Deletes an existing serial port service for a terminal or modem
<code>admserialls</code>	Lists the existing services for the specified serial ports

---

# Files Modified by Serial Port Manager

Table 8-3 describes the files that are modified by Serial Port Manager on the system where you are modifying the serial port services.

**TABLE 8-3** Files Modified by Serial Port Manager

System File	Description
<code>/etc/saf/_sactab</code>	The Service Access Facility's administrative file that contains configuration data for the port monitors it controls
<code>/etc/saf/pmtag/_pmtab</code>	The port monitor's administrative file that contains port monitor-specific configuration data for the services it provides
<code>/var/saf/pmtag/log</code>	The port monitor's log file logging service states: successful initialization, failure, enabled, or disabled

---

## Using Serial Port Manager

By using serial port manager, you can accomplish a number of tasks. The following procedures describe each of these tasks.

### ▼ How to Start Serial Port Manager

1. **Verify that the prerequisite steps described in Chapter 1, are met.**
2. **Type `solstice &` from a Command or Shell Tool prompt and press Return.**
3. **Click the Serial Port Manager icon.**  
The Serial Port Manager main window is displayed.

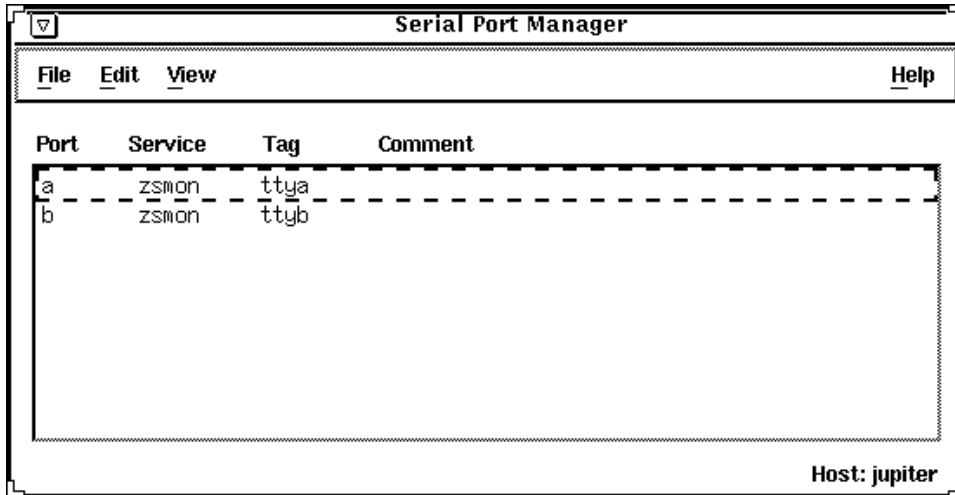

4. (Optional) Choose Host from the View menu.
  - a. Select the host you wish to access using Serial Port Manager.  
You can also type in the name of the host in the selection field.
  - b. Click on OK to access the host using Serial Port Manager.

## ▼ How to Configure Multiple Ports Using Serial Port Manager

1. Start Serial Port Manager from the Solstice Launcher, if not done already.  
See the procedure on "How to Start Serial Port Manager" on page 142 for information about starting Serial Port Manager.
2. Select the ports that you would like to modify.  
You can select more than one port by single-clicking on each port listed in the Serial Port Manager main window.
3. Select the Modify option from the Edit pull-down menu.

## ▼ How to Add a Terminal

1. Start Serial Port Manager from the Solstice Launcher, if not done already.

See the procedure on “How to Start Serial Port Manager” on page 142 for information about starting Serial Port Manager.

- 2. Select the port or ports that will be used with a terminal in the Serial Port Manager main window.**
- 3. Choose Modify from the Edit menu.**  
The Modify window is displayed in the Basic Detail mode. (For additional details, click on More or Expert.)
- 4. Choose Terminal – Hardwired from the Template menu.**
- 5. Change values of template entries if desired.**
- 6. Click on OK to configure the port.**

## Example of a Command-Line Equivalent for Adding a Terminal

The following example is the equivalent of using Serial Port Manager to enable a terminal connection to port `/dev/term/a`.

```
# admserialmod -e -p hw a
```

In this command,

<code>-e</code>	Enables the port.
<code>-p hw</code>	Specifies that the hardwired template be used to configure the port.
<code>a</code>	Specifies the name of the port, in this case port <code>a</code> .

## ▼ How to Add a Modem

- 1. Start Serial Port Manager from the Solstice Launcher, if not done already.**  
See the procedure on “How to Start Serial Port Manager” on page 142 for information about starting Serial Port Manager.
- 2. Select the port or ports that will be used with a modem from the Serial Port Manager main window.**



**3. Choose Modify from the Edit menu.**

The Modify window appears in the Basic Detail mode. (For additional details, select either the More or Expert Detail modes.)

**4. Choose the modem configuration from the Template menu that meets or most closely matches your modem service.**

The modem template choices are described here.

Modem Configuration	Description
Modem – Dial In Only	Users may dial in to the modem but cannot dial out.
Modem – Dial Out Only	Users may dial out from the modem but cannot dial in.
Modem – Bidirectional	Users may either dial in or out from the modem.

See the Reference online help for the default values of each template. If a UUCP service will be used to dial in to your modem on a Solaris 2.x system, see “How to Configure a Modem for Use With UUCP” on page 146 for the rest of the procedure.

**5. Change values of template entries if desired.**

**6. Click on OK to configure the port.**

## Example of a Command-Line Equivalent for Adding a Modem

The following example is the equivalent of using Serial Port Manager to enable a modem to port `/dev/term/b`.

```
# admserialmod -e -p bi -b 38400 b
```

In this command,

<code>-e</code>	Enables the port.
<code>-p bi</code>	Specifies the bidirectional template be used to configure the port.
<code>-b 38400</code>	Specifies the baud rate.
<code>b</code>	Specifies the name of the port.

## ▼ How to Configure a Modem for Use With UUCP

UUCP sends information using seven bits and even parity. Solaris software modem configurations use eight bits and no parity for internationalization purposes. To set up your modem service to work with UUCP, follow these instructions.

- 1. Start Serial Port Manager from the Solstice Launcher, if not done already.**  
See the procedure on “How to Start Serial Port Manager” on page 142 for information about starting Serial Port Manager.
- 2. From the Serial Port Manager main window, select the port or ports that will be used with a modem.**
- 3. Choose Modify Service from the Edit menu.**  
The Modify Service window appears in the Basic Detail mode. (For additional details, select either the More or Expert Detail modes.)
- 4. Choose the modem configuration from the Template menu that meets or most closely matches your modem service.**
- 5. Select Other from the Baud Rate menu.**
- 6. Enter a baud rate value from the `/etc/ttydefs` file that provides seven bit, even parity service and click on OK.**  
In this example, the 9600E baud rate was selected. This provides a service with a 9600 baud rate, seven bits, and even parity.
- 7. Change values of other template entries if desired.**
- 8. Click on OK to configure the port.**

### Example of a Command-Line Equivalent for Adding a Modem

The following example is the equivalent of using Serial Port Manager to enable a modem (for use with UUCP) to port `/dev/term/b`.

```
# admserialmod -e -p bi -b 9600E b
```

In this command,

-e	Enables the port.
-p bi	Specifies the bidirectional template be used to configure the port.
-b 9600E	Specifies the baud rate.
b	Specifies the name of the port.

## ▼ How to Initialize a Port Without Configuring

### 1. Start Serial Port Manager from the Solstice Launcher, if not done already.

See the procedure on “How to Start Serial Port Manager” on page 142 for information about starting Serial Port Manager.

### 2. Choose Modify from the Edit menu.

The Modify window appears in the Basic Detail mode. See the Reference online help for default values of the Basic, More, or Export Detail modes.

### 3. Choose Initialize Only – No Connection from the Template menu.

### 4. Click on OK to initialize the port.

## Example of a Command-Line Equivalent for Initializing a Modem

The following example is the equivalent of using Serial Port Manager to initialize port /dev/term/b.

```
# admserialmod -e -p init b
```

In this command,

-e	Enables the port.
-p init	Specifies the port should only be initialized.
b	Specifies the name of the port.

## ▼ How to Disable a Port



---

**Warning** - Be careful that when disabling a port that you do not disable the port used for the console because when you reboot, no console would be available to you.

---

1. **Start Serial Port Manager from the Solstice Launcher, if not done already.**  
See “How to Start Serial Port Manager” on page 142 for information about starting Serial Port Manager.
2. **Select the port or ports that you want to disable from the Serial Port Manager main window.**
3. **Choose Modify from the Edit menu.**
4. **Select the Service Enable item in the Modify window to disable the port.**  
The other items in the Modify window will turn gray when the port service is disabled.
5. **Click on OK to disable the port.**

### Example of a Command-Line Equivalent for Disabling a Port

The following example is the equivalent of using Serial Port Manager to disable port /dev/term/b.

```
# admserialmod -d b
```

## ▼ How to Delete a Port Service



---

**Warning** - Be careful that when deleting a port that you do not delete the port used for the console because when you reboot, no console would be available to you.

---

1. **Start Serial Port Manager from the Solstice Launcher, if not done already.**  
See the procedure on “How to Start Serial Port Manager” on page 142 for information about starting Serial Port Manager.
2. **Select the port or ports with a service you want to delete from the Serial Port Manager main window.**
3. **Choose Delete from the Edit menu. A window is displayed asking you to confirm that the service should be deleted.**

4. Click on OK when you are ready to delete the service.

### Example of a Command-Line Equivalent for Deleting a Port Service

The following example is the equivalent of using Serial Port Manager to disable port /dev/term/b.

```
# admserialdel b
```



## Setting Up SunSoft Print Client Software With Printer Manager

---

This chapter provides the procedures for setting up and managing the SunSoft print client software by using the Printer Manager application, a graphical user interface within the Solstice AdminSuite software.

This is a list of the step-by-step instructions in this chapter.

- “How to Start Printer Manager” on page 154
- “How to Install a Printer” on page 156
- “How to Install a Network Printer” on page 158
- “How to Add Access to a Printer” on page 161
- “How to Modify Printer Information” on page 163
- “How to Delete Access to a Printer” on page 165
- “How to Delete a Printer From a Print Server (If No Name Service)” on page 166

---

**Note** - The Printer Manager tasks are only part of what you need to know to effectively set up and manage the SunSoft print client software. The *Solstice AdminSuite Printer Administration Guide* provides an overview that helps you understand the SunSoft print process. It also contains task information about converting the configuration information for existing printers and copying the information to SunSoft print clients.

---

For step-by-step instructions on administering printing, see the *System Administration Guide*.

You can set up printing by using LP print service commands instead of Printer Manager. For detailed examples, see the *System Administration Guide*.

---

# Files Modified by Printer Manager

Table 9-1 describes the SunSoft and Solaris system files that are modified by Printer Manager.

**TABLE 9-1** Files Modified by Printer Manager

<b>System File</b>	<b>Description</b>
<code>/etc/printers.conf</code>	A file containing printer configuration information for SunSoft print client operation
<code>printers.conf.byname</code>	An NIS map that contains printer configuration information for SunSoft print client operation
<code>fns.ctx_dir</code>	An NIS+ map that contains printer configuration information for SunSoft print client operation and other information
<code>/etc/lp/printers/<i>printer</i>/*</code>	A Solaris file containing LP printer configuration information
<code>/etc/lp/interfaces/<i>printer</i></code>	A Solaris shell script used to communicate with a local printer
<code>/etc/lp/default</code>	A Solaris file containing the name of the LP system default printer
<code>/etc/lp/filter.table</code>	A Solaris lookup table containing the configured LP filters
<code>/etc/lp/Systems</code>	A Solaris file containing a list of remote systems for Solaris LP
<code>/etc/saf/sactab</code>	A Solaris file containing service access facility configuration
<code>/etc/saf/tcp_pmtab</code>	A Solaris file containing port monitor configuration



---

# Setting Up and Managing SunSoft Print Client Software

Table 9–2 gives you an overview of the tasks for using Printer Manager to set up and manage printing services with the SunSoft print client software.

**TABLE 9–2** Task Map: Setting Up and Managing SunSoft Print Client Software

<b>Activity</b>	<b>Description</b>	<b>For Instructions, Go To</b>
Install a Printer on a Print Server	<b>Install a Printer</b> Install a printer on the system to which it is attached. This procedure tells the system about the printer so the system can act as a print server. If you use a name service, this task also makes the printer available to all SunSoft print clients.	“How to Install a Printer” on page 156
Install a Network Printer	<b>Install a Network Printer</b> Installs a printer to your network that provides access to all network users.	“How to Install a Network Printer” on page 158
Give Print Clients Access to a Printer	<b>Add Access to a Printer</b> Give SunSoft print clients access to a printer that is installed on a print server.	“How to Add Access to a Printer” on page 161
Modify Existing Information for a Printer	<b>Modify Printer Information</b> Modify the current configuration information for a printer.	“How to Modify Printer Information” on page 163

---

TABLE 9-2 Task Map: Setting Up and Managing SunSoft Print Client Software (continued)

Activity	Description	For Instructions, Go To
Delete Access to a Printer	Delete Access to a Printer Delete access to a printer from the NIS or NIS+ master file or from each specified print client's <code>/etc/printers.conf</code> file if you do not use a name service.	"How to Delete Access to a Printer" on page 165
	Delete a Printer From a Print Server Delete a printer from the print server's <code>/etc/printers.conf</code> file. This step applies only if you are not using a name service.	"How to Delete a Printer From a Print Server (If No Name Service)" on page 166

## Starting Printer Manager

To use Printer Manager to complete all the tasks necessary to set up and maintain the SunSoft print client software, first, start the Printer Manager application with Solstice AdminSuite.

### ▼ How to Start Printer Manager

**1. Verify that the following prerequisites are met. To use the Solstice AdminSuite software, you must have:**

- A bit-mapped display monitor. The Solstice AdminSuite software can be used only on a system with a console that is a bit-mapped screen such as a standard display monitor that comes with a Sun workstation.
- If you want to perform administration tasks on a system with an ASCII terminal as the console, use Solaris commands instead.
- OpenWindows software. Start this software with the following command:

```
$ /usr/openwin/bin/openwin
```

- Membership in the `sysadmin` group (group 14).
- The required access privileges for managing the NIS or NIS+ database. If your name service is NIS+, you must be a member of the NIS+ admin group.
- Federated Naming Service (FNS) software.
- If your name service is NIS+, you must initialize the NIS+ namespace to use FNS by entering the following command:

```
$ fncreate -t org org//
```

This command creates the organization context and default subcontexts for an existing NIS+ domain. It also creates NIS+ tables and directories in the NIS+ hierarchy.

**2. Log in as yourself.**

You should use the Solstice AdminSuite software as a regular user who has membership in the sysadmin group rather than as root.

**3. Start the Solstice Launcher.**

```
$ solstice &
```

The Solstice Launcher window is displayed.

**4. Click on the Printer Manager icon to start the application.**



## Printer Manager

The Load window is displayed as an overlay on the Printer Manager main window.

**5. Select the name service used in your network.**

Choices are: NIS+, NIS, or None.

**6. Check that the domain or host name is correct.**

If not, type the host name you need to access. The NIS or NIS+ domain name is static and can not be changed.

**7. Click on OK.**

The Printer Manager main window is displayed by itself after you click on OK.

---

# Installing a Printer

When you use Printer Manager to install a printer on a system, you define the characteristics of the printer and identify the users who are permitted to access it. The system on which you install the printer becomes the *print server*.

Installing a printer means something different depending on whether you use a name service.

---

If You ...	Then Printer Manager ...
Use a name service	Adds the printer in the NIS or NIS+ master file, and the printer is available to all SunSoft print clients
Don't use a name service	Adds the printer in the print server's configuration files only, and print clients do not know about the printer

---

## ▼ How to Install a Printer

### 1. Connect the printer to a system and turn on the power to the printer.

Consult the printer vendor's installation documentation for information about the hardware switches and cabling requirements.

### 2. Start Printer Manager.

When you log in:

- If your name service is NIS or NIS+, you can log in on any system on the network because you'll be able to specify the system on which you are installing the printer.
- If you are not using a name service, you can log in on any system on the network and change the host name in the Load window to the name of the system to which you attached the printer.

For detailed information about starting Printer Manager, see the procedure on "How to Start Printer Manager" on page 154.

### 3. Select Install Printer from the Edit menu.

The Install Printer window is displayed.

### 4. Fill in the window.

If you need information to complete a field, click on the Help button to see field definitions for this window.

### 5. Click on OK.

If you are using NIS or NIS+, the printer is entered in the name service master file and all SunSoft print clients have access to it. The printer is also entered in the print server's `/etc/printers.conf` file and `/etc/lp` directory.

If you are not using a name service, the printer is entered in the print server's `/etc/printers.conf` file and `/etc/lp` directory.

## Verification

Verify that the printer has been installed by checking for the new printer entry in the Printer Manager main window.

## Example of a Completed Install Printer Window

This example shows the Install Printer window when Printer Manager was loaded without a name service. If you use a name service, you can specify any system on the network as the print server in this window.

If you are not using a name service, the Print Server field displays the host name you specified in the Load window, and you cannot change the name of the print server in this window.

**Printer Manager: Install Printer**

Printer Name:

Print Server:

Description:

Printer Port:

Printer Type:

File Contents:

Fault Notification:

Options:  Default Printer  
 Always Print Banner

User Access List:

---

## Installing Network Printers

Installing a network printer can only be done if you are running Solaris 2.6.

### ▼ How to Install a Network Printer

#### 1. Start Printer Manager.

You can log in on any system on the network to install a network printer from a print server. Select None as the name service and change the host name to the name of the print server.

For detailed information about starting Printer Manager, see the procedure on “How to Start Printer Manager” on page 154.

**2. Select Install Network Printer from the Edit menu.**

The Install Network Printer window is displayed.

**3. Fill in the window.**

If you need information to complete a field, click on the Help button to see field definitions for this window.

**4. Click on OK.**

## Verification

Verify that the printer has been installed by checking for the new printer entry in the Printer Manager main window.

## Example of a Completed Install Network Printer Window

This example shows a completed Install Network Printer Window.

**Printer Manager: Install Network Printer**

Printer Name:

Print Server: **ppdog**

Description:

Printer Port: **/dev/null**

Printer Type:

File Contents:

Fault Notification:

Destination:

Protocol:

Options:  Default Printer  
 Always Print Banner

User Access List:

---

## Adding Access to a Printer

When you give a system access to a printer that is attached to a print server, that system becomes a *print client*. You may not need to add access for SunSoft print clients depending on whether you installed the printer through Printer Manager and whether you use a name service.



<b>If You Installed the Printer Through ...</b>	<b>Then ...</b>
Printer Manager and you have a name service	The printer is already available to all SunSoft print clients. You don't need to add access to the printer.
Printer Manager and you don't have a name service	You need to add access to the printer for SunSoft print clients.
UNIX commands and you have a name service	Unless you converted information for this printer from a SunOS 5.x or 4.x system and loaded NIS or NIS+, the printer is not listed in the name service. You need to add access to the printer so it will be entered in the name service and made available to all SunSoft print clients.
UNIX commands and you don't have a name service	Unless you converted information for this printer from a SunOS 5.x or 4.x system and copied the master <code>/etc/printers.conf</code> file to print clients, you need to add access for SunSoft print clients. (If a print client had access previously, that access has been erased.)

## ▼ How to Add Access to a Printer

### 1. Start Printer Manager.

You can add access to a printer from any system on the network.

- If you use a name service, you don't need to specify print clients. You add access to the printer for all SunSoft print clients on the network.
- If you don't use a name service, you will be able to specify the print clients to be given printer access.

For detailed information about starting Printer Manager, see the procedure on "How to Start Printer Manager" on page 154.

### 2. Select Add Access to Printer from the Edit menu.

The Add Access to Printer window is displayed.

### 3. Fill in the window.

If you need information to complete a field, click on the Help button to see field definitions for this window.

### 4. Click on OK.

If your name service is NIS or NIS+, the printer is entered in the name service master file and all SunSoft print clients have access to it.

If your name service is None, the printer is entered in the `/etc/printers.conf` file of each print client you specified.

---

**Note** - Do not try to add access in NIS or NIS+ on the print server. However, you can delete the printer in the None naming service, then install the printer in the correct naming service.

---

## Verification

Verify that the access has been added by submitting a print request from the print client and checking the printer for output.

## Example of a Completed Add Access to Printer Window

In this example, the network does not use a name service, so the window contains the Print Clients field. This field enables you to specify the print clients to be given access to the specified printer. If the name service is NIS or NIS+, the window does not contain the Print Clients field.

**Printer Manager: Add Access To Printer**

**Print Clients:** Lorna

Add Delete

**Printer Name:** plutq

**Print Server:** earth

**Description:** room 152, postscript

**Option:**  Default Printer

OK Apply Reset Cancel Help

---

# Modifying Printer Information

After you've installed a printer through Printer Manager, you can modify some of the information originally entered. You can also set two additional options that control the printer's ability to accept and process print requests.

The Modify window of Printer Manager has two versions. On the short version, you can change only the printer description and whether the printer is set up as the default printer. You'll see the short window if:

- You don't use a name service and the printer is not local to the print server.
- You are not a member of the sysadmin group (group 14), regardless of your name service selection.
- The print server does not have the Solstice AdminSuite software.

Otherwise, you'll get the long version of the window, where you can change more information and set the options for accepting and processing print requests.

---

**Note** - You can't change certain printer information even on the long version of the window. If you need to change the printer name, print server, or printer type, you'll have to delete the printer and reinstall it. For these procedures, see and .

---

## ▼ How to Modify Printer Information

### 1. Start Printer Manager.

You can log in on any system on the network. For detailed information about starting Printer Manager, see the procedure on "How to Start Printer Manager" on page 154.

### 2. Select the printer that you want to modify from the scrolling list in the Printer Manager main window.

### 3. Select **Modify** from the **Edit** menu or double-click on the printer name in the scrolling list.

The short version or the long version of the Modify window is displayed.

### 4. Fill in the window.

If you need information to complete a field, click on the Help button to see field definitions for this window.

### 5. Click on **OK**.

---

**Note** - If the modify action is not on the printer server, a warning window is displayed stating that the print server information was not modified.

---

## Verification

Verify that the printer information has been changed by reloading Printer Manager and checking for your changes, as follows:

- 1. Select Load from the File menu.**  
The Load window is displayed.
- 2. Leave the settings as they are, and click on OK.**  
The Printer Manager main window is displayed.
- 3. Select the printer you just modified from the scrolling list in the Printer Manager main window.**
- 4. Select Modify from the Edit menu.**  
The Modify window is displayed.
- 5. Check to see if your changes to the printer information are displayed.**

## Example of a Completed Modify Window

This example shows the short version of the Modify window. The long version contains more field; it displays the printer name and print server, and enables you to change the printer description, destination, printer port, file contents, fault notification, and user access list. In addition, the long version enables you to select the following options: default printer, print banner, accept print requests, and process print requests.

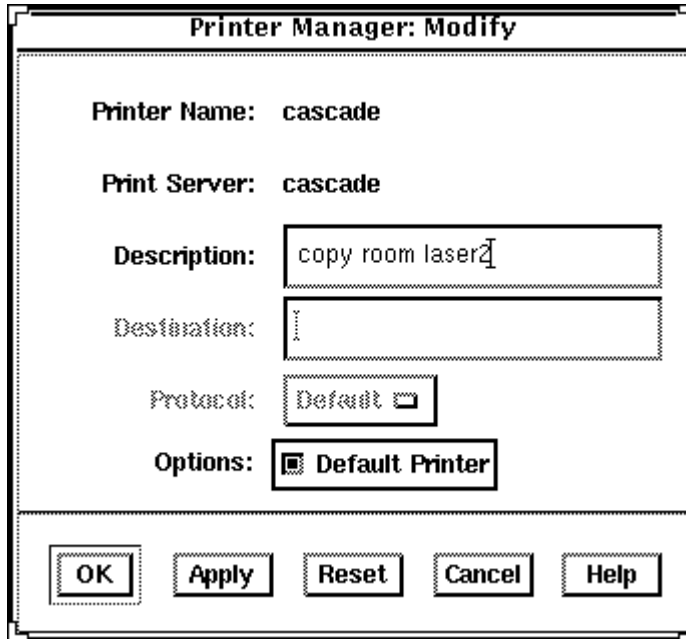

---

## Deleting Access to a Printer

The only way to change the name, print server, or printer type originally assigned to a printer is to delete the printer and reinstall it using new information.

If you need to move, replace, or reinstall a printer with new information, you should first make sure that all the print requests in the printer's queue are printed or moved to another printer. You must also delete print clients' access to the printer and delete the printer from the print server before you physically detach the printer from the print server.

If your name service is NIS or NIS+, you delete access to a printer and delete the printer from the print server at the same time.

If you are not using a name service, you must first delete access to a printer for each print client and then delete the printer from the print server as a separate task.

### ▼ How to Delete Access to a Printer

#### 1. Start Printer Manager.

You can log in on any system on the network to delete access to a printer.

- If your name service is NIS or NIS+, you won't need to specify print clients. You delete access to the printer for all SunSoft print clients on the network and delete the printer from the print server at the same time.
- If you are not using a name service, you can log in on any system on the network and change the host name to the name of the print client for which you want to delete printer access.  
For detailed information about starting Printer Manager, see the procedure on "How to Start Printer Manager" on page 154.

**2. Select the printer for which you want to delete access from the scrolling list in the Printer Manager main window.**

**3. Select Delete from the Edit menu.**

The Warning window is displayed. It contains a prompt asking you to verify that you really want to delete the printer.

**4. Click on OK.**

If your name service is NIS or NIS+, the printer is deleted from the name service master file and access is removed for all print clients. The printer is also deleted from the print server's `/etc/printers.conf` file and `/etc/lp` directory.

If you are not using a name service, the printer is deleted only from this print client's `/etc/printers.conf` file. You must repeat steps 1 through 4 to delete access to the printer for other SunSoft print clients.

## Verification

If your name service is NIS or NIS+, verify that the printer has been deleted from the name service by making sure that the printer is not listed in the Printer Manager main window.

If you are not using a name service, verify that the print client's access has been deleted by making sure that the printer is not listed in the Printer Manager main window.

## ▼ How to Delete a Printer From a Print Server (If No Name Service)

**1. Start Printer Manager.**

You can log in on any system on the network to delete a printer from a print server. Select None as the name service and change the host name to the name of the print server.

For detailed information about starting Printer Manager, see the procedure on "How to Start Printer Manager" on page 154.

2. **Select the printer to be deleted from the scrolling list in the Printer Manager main window.**
3. **Select Delete from the Edit menu.**  
The Warning window is displayed. It contains a prompt asking you to verify that you really want to delete the printer.
4. **Click on OK.**  
The printer is deleted from the print server's `/etc/printers.conf` file and `/etc/lp` directory.

## Verification

Verify that the printer has been deleted from the print server by making sure that the printer is not listed in the Printer Manager main window.

---

## Where to Go From Here

After you have set up the systems at your site to use the SunSoft print client software, users may also want to set up their `~/.printers` home directory to contain custom printer aliases.

For step-by-step instructions on these tasks, see the *Solstice AdminSuite 2.3 Print Administration Guide*.





# Managing Network Service Files With Database Manager

---

This chapter describes how to manage network services by using Database Manager, a graphical user interface within the Solstice AdminSuite software used to manage network-related system files.

This is a list of the step-by-step instructions in this chapter.

- “How to Start Database Manager” on page 171
- “How to Add a System File Entry” on page 172
- “How to Modify a System File Entry” on page 173
- “How to Delete a System File Entry” on page 174

---

## Overview of Database Manager

Database Manager is primarily used to manage the network-related system files since other tools are used to manage user, client system, serial ports, and printer-related files. With Database Manager, you can edit system files in a system's `/etc` directory, NIS name service, or the NIS+ name service.

Using Database Manager to add an entry to a system file usually managed by another tool can save time. For example, Host Manager requires you to enter the Ethernet address when adding a standalone system even though you may want to use this system for remote copy and login only. However, the Ethernet address is not required when you use Database Manager to update the `hosts` file.



---

**Caution** - It is important that you do not bypass critical information when providing services to users and client systems. Use caution when using Database Manager to update system files normally managed by other tools.

---

---

## Files Modified by Database Manager

The network-related system files that can be modified with Database Manager are described in Table 10-1.

**TABLE 10-1** Files Modified by Database Manager

<b>System File</b>	<b>Description</b>
<code>aliases</code>	Aliases in ASCII format for the local host. Or, if it is a NIS+ or NIS file, aliases available for use across the network.
<code>auto.home</code> (NIS) or <code>auto_home</code> (NIS+ or /etc)	Entries for client systems to mount their home directories automatically; an indirect automounter map.
<code>bootparams</code>	Entries client systems need to boot from the network.
<code>ethers</code>	Ethernet addresses of network client systems.
<code>group</code>	Entries that define group access.
<code>hosts</code>	Entries for systems on the network and their associated IP addresses.
<code>locale</code>	The default locales used by network clients.
<code>netgroup</code>	Entries for netgroups, a group of systems granted identical access to network resources for security and organizational reasons.
<code>netmasks</code>	Network mask values used to implement IP subnetting.
<code>networks</code>	Information about available networks.
<code>passwd</code>	Entries for the password.

TABLE 10-1 Files Modified by Database Manager (continued)

System File	Description
protocols	Information about Internet protocols used in your network.
rpc	Entries for available RPC services (by name) and their associated program numbers and aliases.
services	Information about network services and their “well-known” port numbers.
timezone	Entries for systems and their geographic region and time zone used at installation.

---

## Managing Network Services Files

The following section describes how to use Database Manager to manage network services files.

### ▼ How to Start Database Manager

1. **Verify that the steps described in Chapter 1, are met.**
2. **Type `solstice &` from a Command or Shell tool prompt and press Return.**  
The Solstice Launcher is displayed.
3. **Click the Database Manager icon.**  
The Load Database window is displayed.
4. **Select the name service used in your network.**
5. **Check that the domain or host name is correct.**  
If not, type the domain or host name you need to access.
6. **Select the file you want to display.**  
Select the `aliases` file, for example.
7. **Click on OK.**

The Database Manager main window is displayed with the file contents displayed.

## Example of the Database Manager Main Window

This example shows that the `aliases` file has been selected and displayed.

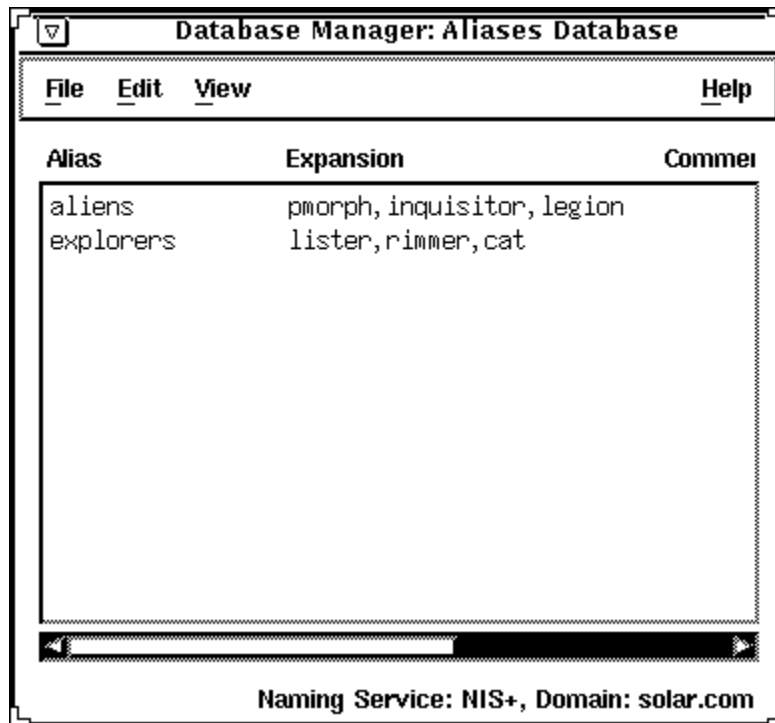

### ▼ How to Add a System File Entry

1. **Start Database Manager from the Solstice Launcher, select the name service, and the system file to be displayed, if not done already.**

See the procedure on "How to Start Database Manager" on page 171 for information about starting Database Manager.

2. **Select Add from the Edit menu in the Database Manager main window.**  
The Add window is displayed.

3. **Fill out the Add window.**

If you need information to complete a field, click on the Help button to see field definitions for the system file.

4. **Click on OK.**

## Verification

Verify that the entry has been added by locating the new entry in the Database Manager's main window.

## Example of Adding a System File Entry Using Database Manager

The following is an example a completed Add window where a mail alias has been added to the `aliases` file.

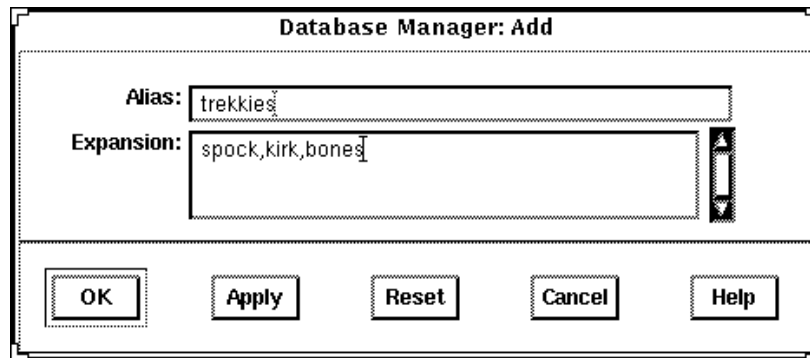

## ▼ How to Modify a System File Entry



---

**Caution** - Notify users before you modify their work environment.

---

- 1. Start Database Manager from the Solstice Launcher and select the name service, if not done already.**  
See the procedure on "How to Start Database Manager" on page 171 for information about starting Database Manager.
- 2. Select a system file to modify in the Database Manager main window.**
- 3. Select Modify from the Edit menu.**  
The Modify window is displayed.
- 4. Fill out the Modify window.**  
If you need information to modify a field, click on the Help button to see field definitions for the system file.
- 5. Click on OK when finished.**

## Verification

Verify that the entry has been modified by locating the entry in the Database Manager's main window.

## Example of Modifying a System File Entry Using Database Manager

The following is an example of the Modify window and a selected system file entry.

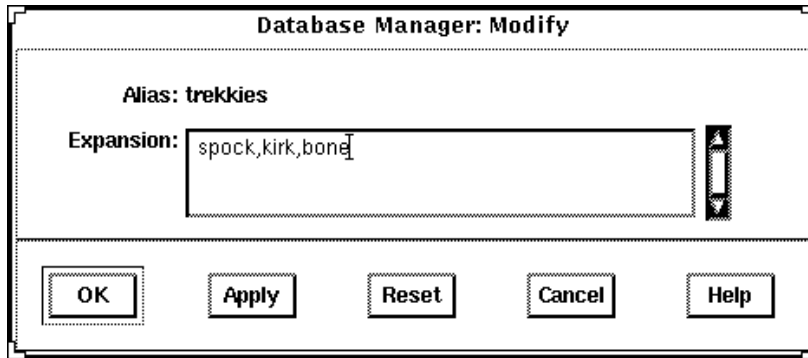

## ▼ How to Delete a System File Entry

1. **Start Database Manager from the Solstice Launcher and select the name service, if not done already.**

See the procedure on "How to Start Database Manager" on page 171 for information about starting Database Manager.

2. **Select an alias entry to delete in the Database Manager main window.**
3. **Select Delete from the Edit menu.**  
A window is displayed asking you to confirm the deletion.
4. **Click on OK if you really want to delete the system file entry.**

## Verification

Verify that the system file has been updated in the Database Manager's main window.

## Example of Deleting a System File Entry Using Database Manager

The following is an example of a Database Manager Delete verification window.

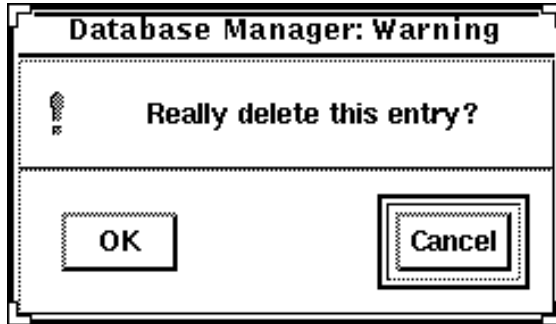





# Managing Disks and File Systems With Storage Manager

---

The Storage Manager application contains two tools, Disk Manager and File System Manager, that enable you to manage disk configurations and file systems on servers that are on your network.

This is a list of the step-by-step instructions in this chapter.

- “How to Load an Initial Context” on page 180
- “How to Load a Different Context” on page 180
- “How to Create a UFS File System” on page 187
- “How to Create a Mount Point” on page 188
- “How to Modify the Properties of a Mount Point or Directory” on page 190
- “How to Mount or Unmount a File System” on page 191
- “How to Share or Unshare a Directory” on page 193
- “How to View Static Client File Systems” on page 194
- “How to View Active Server File Systems” on page 196
- “How to View Static Server File Systems” on page 197
- “How to Remove a Mount Point From the `/etc/vfstab` File” on page 198
- “How to Specify a Viewing Filter” on page 205
- “How to Specify a Volume Label” on page 206
- “How to Modify `fdisk` Partitions” on page 207
- “How to Modify Slice Geometry” on page 208
- “How to Clone a Disk” on page 209

---

# Storage Manager's Load Context Property Book

Storage Manager introduces the concept of a *property book* to the Solstice AdminSuite product. A property book is the mechanism by which you identify, view, and modify the properties of editable *objects*, such as disks or file systems. A property book, using a book metaphor, contains a list of chapters that represent properties for the object. You can expand each chapter to view or modify the properties.

The purpose of the Load Context Property Book is for you to set the *context* in which Storage Manager will operate. Generally, a context is the way to manage the properties of an object. In the case of File System Manager, the context includes which host to manage, what name service to modify or how to view and modify the file systems on a server. In the case of Disk Manager, the context includes what *diskset* (a logical grouping of disks) to modify if you have the Solstice DiskSuite™ 4.0 software installed on the system. For more information on Solstice DiskSuite, see *Solstice DiskSuite 4.0 Administration Guide* and *Solstice DiskSuite Tool 4.0 Users Guide*.

The Load Context Property Book is displayed when you start Storage Manager from the Solstice Launcher. You can also display this window by choosing Load from the File menu in either Disk Manager or File System Manager, or by clicking on the Load Context icon in either tool bar. Figure 11-1 shows the Storage Manager's Load Context Property Book.

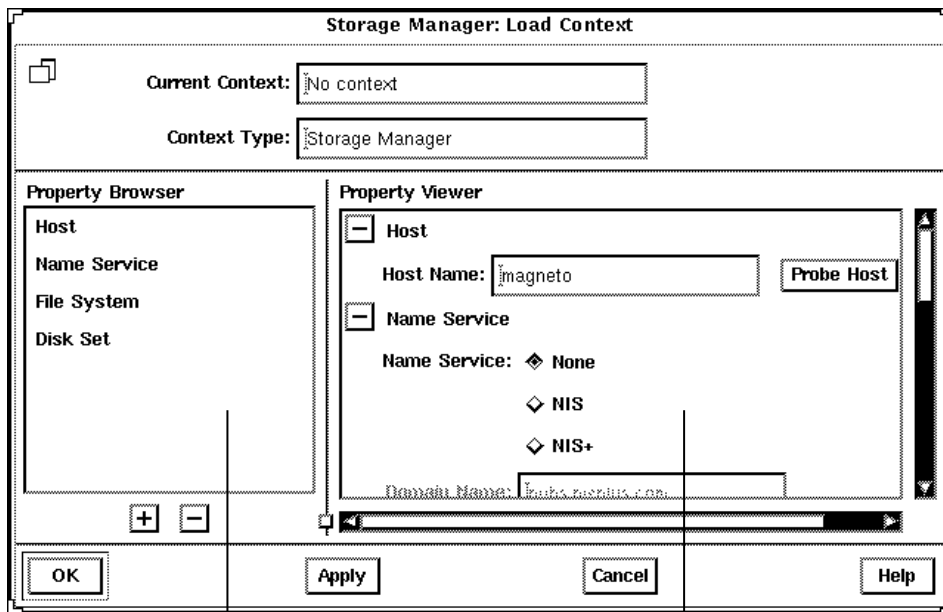

Chapters

Chapter Properties

*Figure 11-1* Storage Manager's Load Context Property Book

Here are some brief descriptions of the areas within Storage Manager's Load Context Property Book:

- **Current Context** – Is a read-only field that displays the host name of the current context. Storage Manager initially has no context set.
- **Context Type** – Is a read-only field that indicates the name of the tool with which the current context is associated. In Figure 11-1, the tool is Storage Manager.
- **Property Browser** – Is like a table of contents in a book. It lists all the *chapters* and subchapters (if any) in the book, which represents properties of an object. The Property Browser enables you to navigate quickly to the desired chapter and to expand or collapse its contents as desired.

Clicking on a chapter in the Property Browser causes the corresponding chapter in the Property Viewer to become visible, if it is not already visible. Double-clicking on a chapter in the Property Browser first makes the chapter visible in the Property Viewer, and then expands or collapses the chapter in the Property Viewer.

- **Chapters** – Contains a common set of properties for the object that you can view or modify.
- **The + and - Buttons** – The buttons that appear below the Property Browser perform an expand all (+) or collapse all (-) function on the chapters in the Property Viewer. This is a quick way of viewing all chapter properties or only the chapter names.

The buttons that appear next to chapter names in property books also perform an expand all or collapse all function, but only on the selected chapter.

- **Property Viewer** – Displays the properties you can set when changing your current context. By default, the chapters in this Property Viewer appear expanded, so that you can easily specify the context on which you want to operate. At a minimum, you must probe a server in the Host chapter in order to specify a context. For more information, see “How to Load a Different Context” on page 180.
- **Chapter Properties** – Enables you to set the context you want to display and modify.

For more reference information on the chapters that are available from the Load Context Property Book (Host, Name Service, File System, Disk Set), refer to online help.

## ▼ How to Load an Initial Context

This procedure assumes that the Load Context window is displayed as a result of clicking on the Storage Manager icon in the Solstice Launcher.

1. **If you want to view or modify the context of the system where you started the Solstice Launcher and Storage Manager, make needed changes to the Name Service, File System, and Disk Set chapters, if any. Skip to Step 5 on page 180.**
2. **If you want to view or modify the context of a system other than the one where you started the Solstice Launcher and Storage Manager, delete the existing name in the Host Name field and type the name of the host whose context you want to view or modify.**
3. **Click on Probe Host.**  
A System Discovery window is displayed, indicating that information is being updated from the specified host.
4. **If desired, make changes to the Name Service, File System, and Disk Set chapters.**
5. **Click on OK.**  
A System Discovery window is displayed, indicating that Storage Manager is validating context parameters as well as discovering devices, directories, and mount points on the specified host.

## ▼ How to Load a Different Context

This procedure assumes that Storage Manager has an active current context (that is, the File System Manager main window or Disk Manager main window is open).

1. **Choose Load from the File menu, or click on the Load Context icon in the tool bar.**

The Load Context window is displayed, with the current context's host name displayed in the Host chapter.

2. **Delete the existing name in the Host Name field and type the name of the host whose context you want to view or modify.**

3. **Click on Probe Host.**

A System Discovery window is displayed, indicating that information is being updated from the specified host.

4. **If desired, make changes to the Name Service, File System, and Disk Set chapters.**

5. **Click on OK.**

A System Discovery window is displayed, indicating that Storage Manager is validating context parameters as well as discovering devices, directories, and mount points on the specified host.

## Example of Loading a Different Context

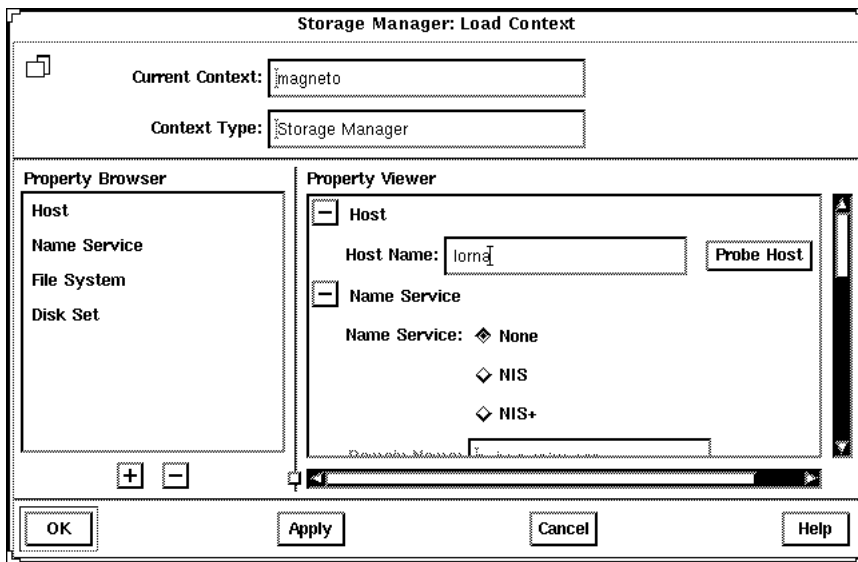

---

# File System Manager Overview

File System Manager is a tool that enables you to create and modify file systems, mount points, and directories using two types of windows, the main window and a Property Book. The main window displays a hierarchical view of directories and file systems, as well as the mount points and shared resources for the current context. The Property Book displays the chapters and their properties for a selected directory or file system that you can view or modify.

Specifically, File System Manager is a tool that enables you to complete the following tasks:

- Create new file systems
- Modify file system options in the `/etc/vfstab` file
- Manage `/etc/vfstab` files on a single or group of diskless clients or AutoClient systems.
- Mount or unmount file systems
- Share or unshare file systems
- Include a file system in existing automounter maps
- Convert a directory into a mount point

For step-by-step instructions on how to complete these tasks, refer to Table 11-1. Also, these instructions are included in the online help provided with the File System Manager tool.

---

## File System Manager's Main Window

Figure 11-2 shows the important areas of the File System Manager's main window.

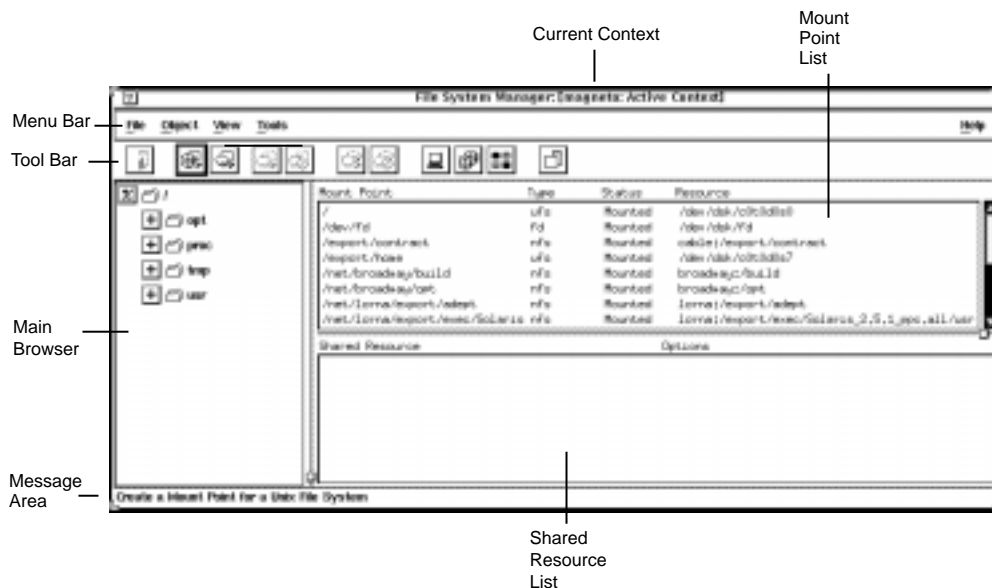

Figure 11-2 File System Manager's Main Window

Here are some brief descriptions of the areas within File System Manager's main window:

- **Current Context** – Specifies the server or clients on the server where you are managing file systems. You can change the current context by choosing Load from the File menu or by clicking on the Load Context icon in the tool bar.
- **Menu Bar** – Displays the menus that enable you to perform operations in File System Manager. For detailed descriptions of the menus, see the online help.
- **Tool Bar** – Displays icons that provide an easier way to select commonly-used operations provided by the main menu, such as mount and unmount, and the ability to launch other tools. When you move the mouse pointer over an active icon, the message area describes what operation the icon will perform. You can choose Toolbar from the View menu to turn the tool bar off or on (by default, it is turned on).
- **Main Browser** – Displays the directory hierarchy for the current context. You can use the navigation buttons to expand or collapse the view of the directories and mount points. The browser initially displays the top-level of the file system hierarchy.
- **The + and - Buttons** – Are three state buttons that are used to expand and collapse the hierarchical structure you are viewing. The three states are:
  - Collapsed all (the + is displayed)
  - Collapsed managed objects (the +/- is displayed)
  - Expanded all (the - is displayed)

The +/- state means that the corresponding entry is only partially expanded or collapsed. Clicking on a button in this state will further expand the entry.

- Message Area – Provides information about the main window or icon where the mouse pointer is located.
- Mount Point List – Displays an entry for each mount point defined in the current context. Each entry contains the full path name of the mount point, the type of file system mounted on that mount point, whether the associated resource is currently mounted on the mount point, and the name of that resource.
- Shared Resource List – Displays an entry for each shared resource (directory or mount point) defined in the current context. Each entry contains the full path name of the resource, followed by the options controlling its export.

---

## File System Manager Property Book

There are three ways to open the File System Manager Property Book.

- Select a mount point or directory in the main window and choose Properties from the Object menu.
- Select a mount point or directory in the main window and click on the Property Book icon in the tool bar.
- Double-click on a mount point or directory in the main window.

Figure 11-3 shows the important features of the File System Manager Property Book.



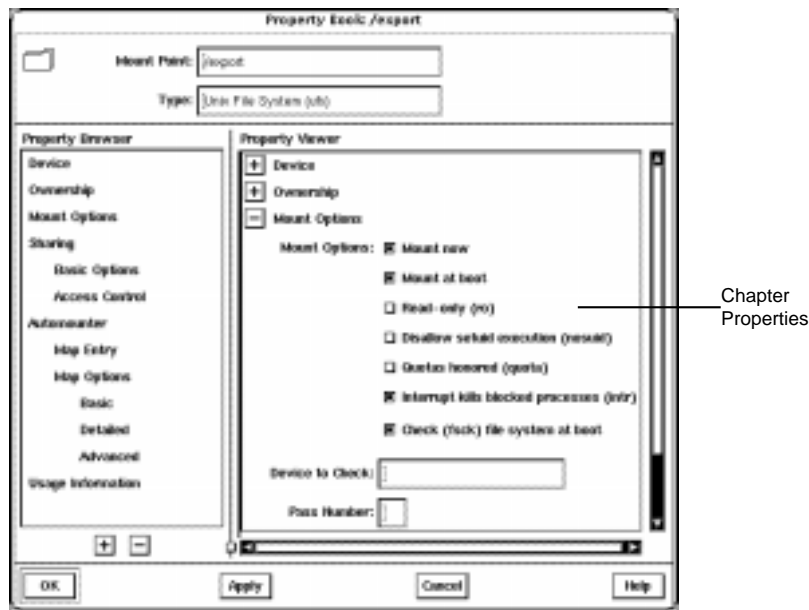

Figure 11-3 File System Manager Property Book

- **Mount Point** – Specifies the name of the mount point that you are managing in the property book. In Figure 11-3 the object is the `/export` mount point.
- **Type** – Specifies the type of the mount point.
- **Property Browser** – Functions much the same way as the Storage Manager Load Context Property Browser. It lists all the chapters and subchapters (if any) for the selected directory, mount point, or file system.

Double-clicking on a chapter expands the chapter in the Property Viewer and displays the subchapters (if any) or the object properties. Double-clicking on a subchapter expands that subchapter in the Property Viewer.

- **Chapter** – Contains a common set of properties for the object that you can view or modify.
- **The + and - Buttons** – The buttons that appear below the Property Browser perform an expand all (+) or collapse all (-) function on the chapters in the Property Viewer. This is a quick way of viewing all chapter properties or only the chapter names.

The buttons that appear next to chapter names in property books also perform an expand all or collapse all function, but only on the selected chapter.

- **Property Viewer** – Enables you to expand and collapse the contents of chapters. You can expand a chapter down to its object properties, enabling you to view or modify the property for the object.

Chapter Properties – Specifies the properties that you can view or modify for the object. There can be one or more properties in a chapter.

For more reference information on the chapters that are available from the File System Manager Property Book, refer to the online help.

---

## Managing File Systems, Mount Points, and Directories With File System Manager

TABLE 11-1 Task Map: Managing Files With File System Manager

Activity	Description	For Instructions, Go To
Create a UFS File System	Create a new file system on a specified device.	“How to Create a UFS File System” on page 187
Create a Mount Point	Create a local (UFS) or remote (NFS) mount point.	“How to Create a Mount Point” on page 188
Modify the Properties of a Mount Point or Directory	Mount or unmount a file system, share or unshare a directory, or modify an automounter map.	“How to Modify the Properties of a Mount Point or Directory” on page 190
Mount or Unmount a File System	Mount or unmount a file system.	“How to Mount or Unmount a File System” on page 191
Share or Unshare a Directory	Share or unshare a directory.	“How to Share or Unshare a Directory” on page 193

TABLE 11-1 Task Map: Managing Files With File System Manager (continued)

Activity	Description	For Instructions, Go To
View Static Client File Systems	View the file systems that are mounted and directories that are shared at boot time on the server's diskless clients and AutoClient systems.	"How to View Static Client File Systems" on page 194
View Active Server File Systems	View the file systems that are currently mounted and the directories that are shared on the server.	"How to View Active Server File Systems" on page 196
View Static Server File Systems	View the server's file systems that are mounted and directories that are shared at boot time on the server.	"How to View Static Server File Systems" on page 197
Remove a Mount Point From /etc/vfstab	Remove a mount point from the /etc/vfstab file.	"How to Remove a Mount Point From the /etc/vfstab File" on page 198

## ▼ How to Create a UFS File System

- 1. Choose Create File System from the Object Menu.**  
The New File System property book is displayed.
- 2. Open the Device chapter.**
- 3. Enter the device name of an unused slice or metadvice on which to create the UFS file system.**  
You can either type the name of a device, or drag and drop a slice from Disk Manager or a metadvice from DiskSuite Tool.
- 4. If you want to verify that the specified device is currently available, click on the Check File System button.**
- 5. If you want to copy the contents of an existing directory into the new file system, open the Population Options chapter and select Populate on Create. Enter the Source Directory from which to copy the contents into the new file system.**

6. Click on OK.

## Example of Creating a UFS File System

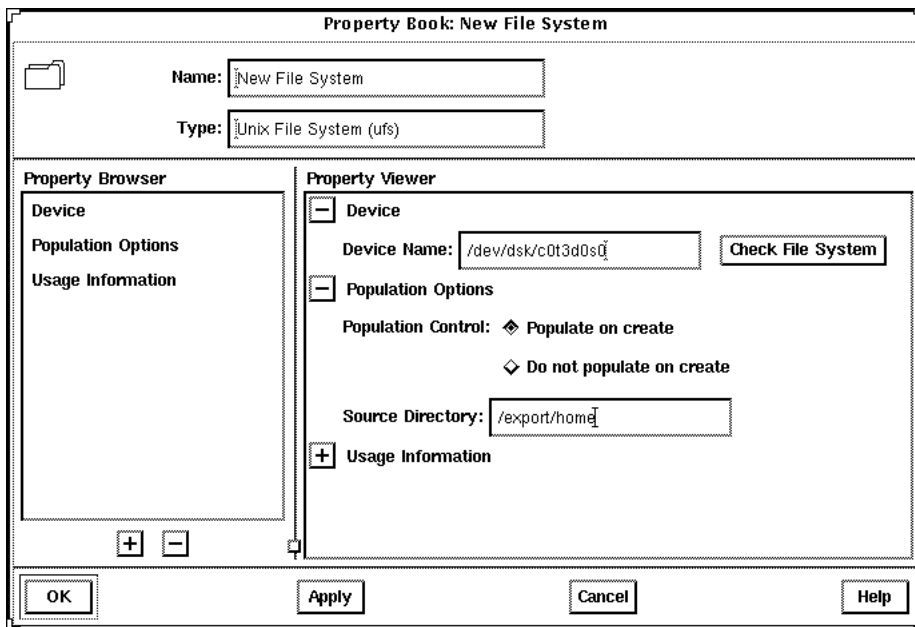

### ▼ How to Create a Mount Point

1. Choose the appropriate mount point option (UFS, NFS, or HSFS) from the Object menu. (You can also click on an icon in the tool bar to create a UFS or NFS mount point.)  
The Mount Point Name window appears.
2. Type a name and click on OK.  
The property book for the mount point is displayed.
3. If you are creating a UFS or HSFS mount point, skip to Step 6 on page 189. If you are creating an NFS mount point, open the Server Path chapter.
4. Type the name of a server and click on Probe Server.  
A list of exported file systems is displayed in the Exported File Systems list.
5. Click on the desired file system name or type a name in the Path Name field.  
Skip to Step 9 on page 189.

**6. Open the Device chapter.**

**7. Enter the device name of an unused slice on which to create the HSFS or UFS mount point.**

You can either type the name of a device or drag and drop a slice from Disk Manager.

**8. If you want to verify that the specified device is currently available, click on the Check File System button.**

**9. Make modifications to the other chapters, if needed.**

For example, in the Mount Options chapter you can choose to mount now and/or mount at boot time.

**10. Click on OK.**

The mount point appears in the Mount Point list.

## Example of Creating a Mount Point

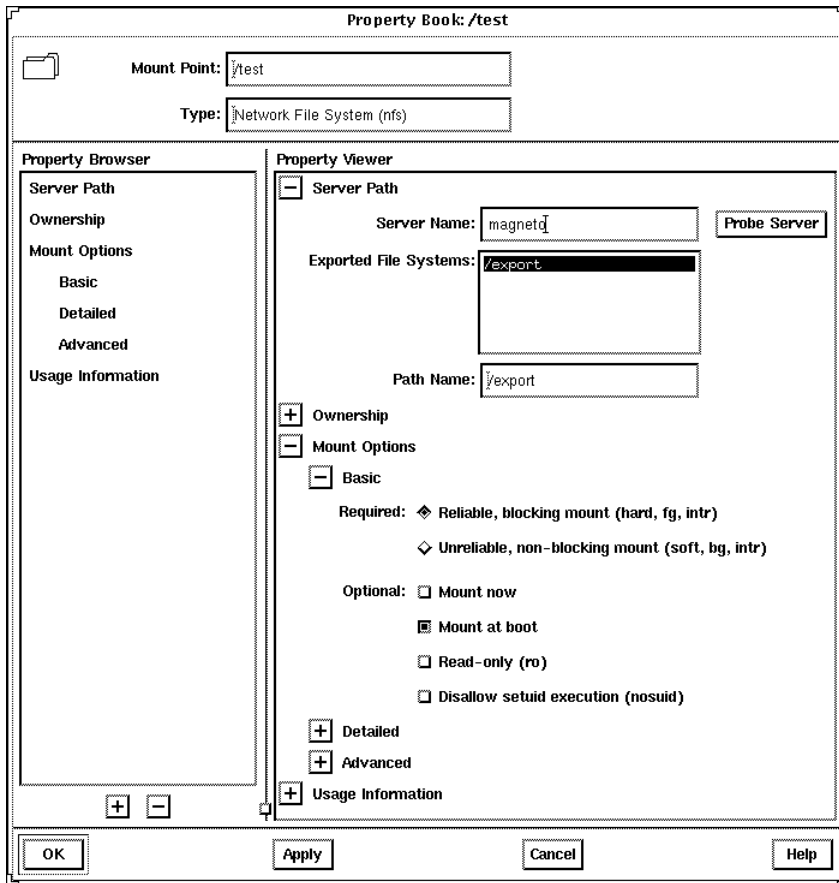

### ▼ How to Modify the Properties of a Mount Point or Directory

#### 1. Select a directory or mount point from the main window.

You can select a directory or mount point from the main browser, the Mount Point list, or the Shared Resource list.

---

**Note** - Once you select a mount point or directory, the Object menu may allow you to automatically mount a file system, unmount a file system, share a directory, or unshare a directory. If you want to complete one of these tasks, it is faster to use the Object menu rather than make the change using the Property Book.

---

#### 2. Choose Properties from the Object menu.

The property book for the file system or directory is displayed.

3. **Open the available chapters to modify the properties for the mount point or directory.**

Click on Help in the property book to see detailed information about each chapter.

4. **Click on OK.**

### Example of a File System Manager Property Book

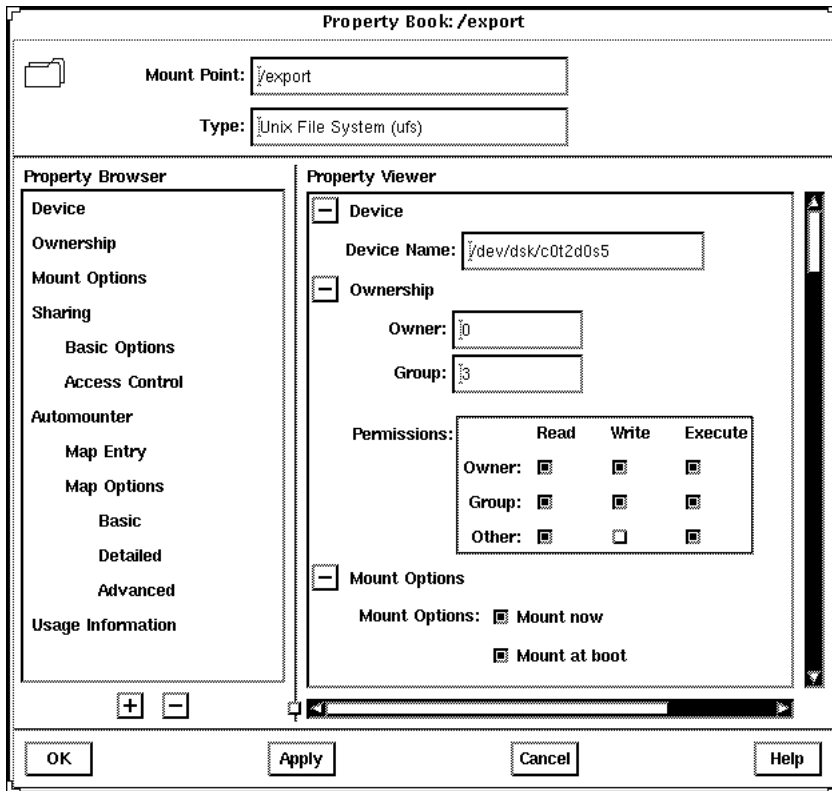

## ▼ How to Mount or Unmount a File System

1. **Select a mount point from the main browser, Mount Point list, or Shared Resource list.**

---

**Note** - Once you select a mount point, the Object menu may allow you to automatically mount or unmount a file system. This method is faster than making the change using the Property Book.

---

**2. Choose Properties from the Object menu.**

The property book for the file system is displayed.

**3. Open the Mount Options chapter to modify the mount options (for example, mount or unmount the file system).**

**4. Click on OK.**

### Example of Mounting a File System

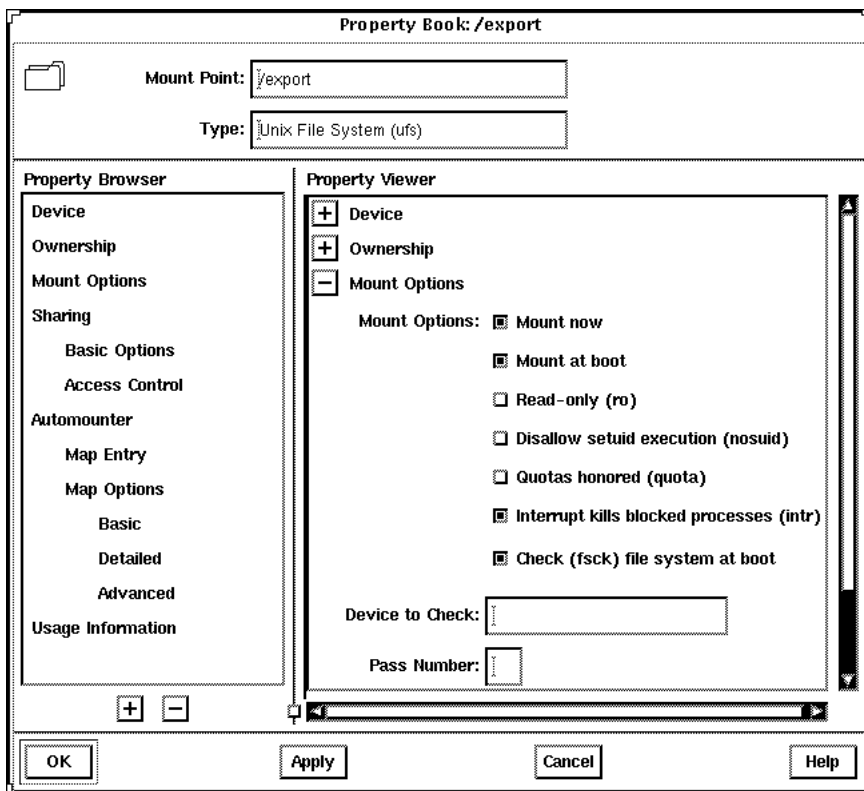



## ▼ How to Share or Unshare a Directory

1. **Select a directory or UFS or HFSFS mount point from the main browser, Mount Point list, or Shared Resource list.**

---

**Note** - Once you select a directory or mount point, the Object menu may allow you to automatically share or unshare it. This method is faster than making the change using the Property Book.

---

2. **Choose Properties from the Object menu.**  
The property book for the file system is displayed.
3. **Open the Sharing chapter to modify the share options (for example, share or unshare the file system).**
4. **Click on OK.**

## Example of Sharing a Directory

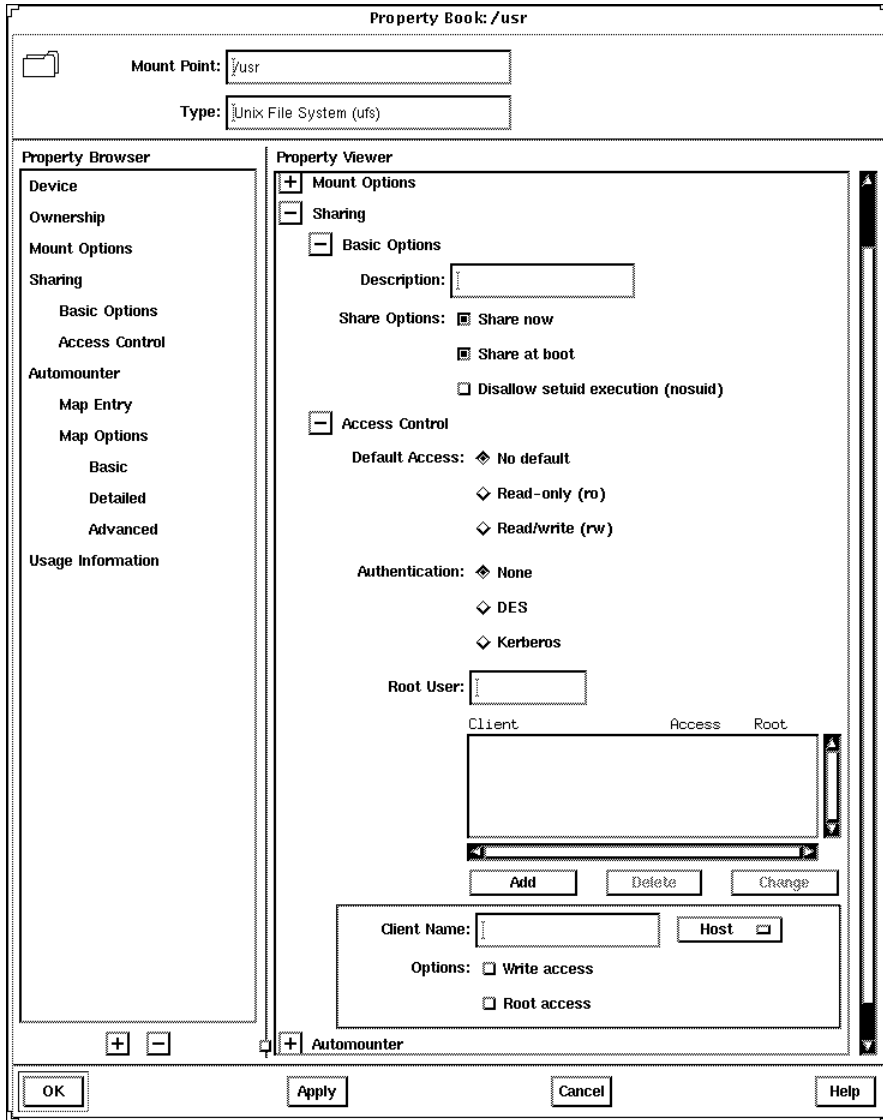

### ▼ How to View Static Client File Systems

*Static client file systems* are those file systems that will be mounted on a server's AutoClient or diskless clients when they boot.

1. **Click on the Load Context icon or choose Load from the File menu.**  
The Load Context property book is displayed.

2. **Open the File System chapter, if not done already.**
3. **Click on the Static Client File System button.**

---

**Note** - This button is only active if there are AutoClient systems or diskless clients configured on the system.

---

The Client Context field is activated.

4. **Select either Client Group or Individual Client.**
5. **Select a system from the Client Group or All Clients list.**
6. **Click on OK.**

The file systems that will be mounted at boot time for the clients are displayed in the Mount Point list on the main window.

The directories that will be shared at boot time for the clients are displayed in the Shared Resources list on the main window.

## Example of Viewing Static Client File Systems

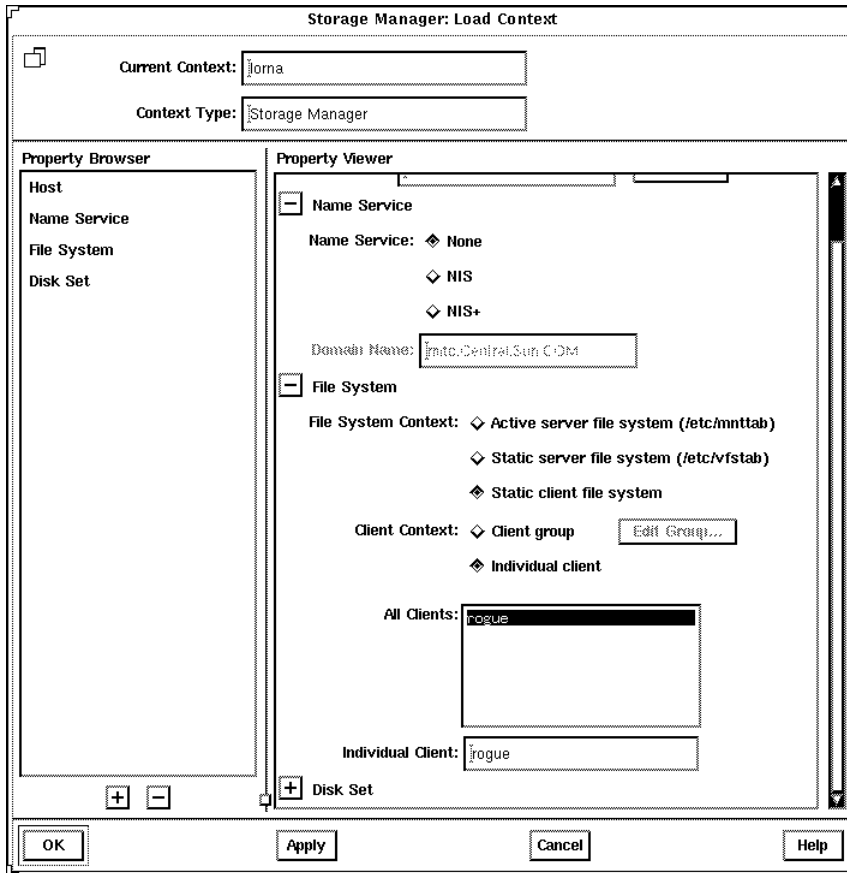

### ▼ How to View Active Server File Systems

*Active server file systems* are the file systems on a server that are currently mounted or shared. This is the same information as contained in the `/etc/mnttab` file and `/etc/dfs/sharetab` files.

- 1. Click on the Load Context icon or choose Load from the File menu.**  
The Load Context property book is displayed.
- 2. Open the File System chapter, if not done already.**
- 3. Click on the Active Server File System button.**
- 4. Click on OK.**

The file systems that are currently mounted on the server are displayed in the Mount Point list on the main window.

The directories that are currently shared on the server are displayed in the Shared Resources list on the main window.

## Example of Viewing Active Server File Systems

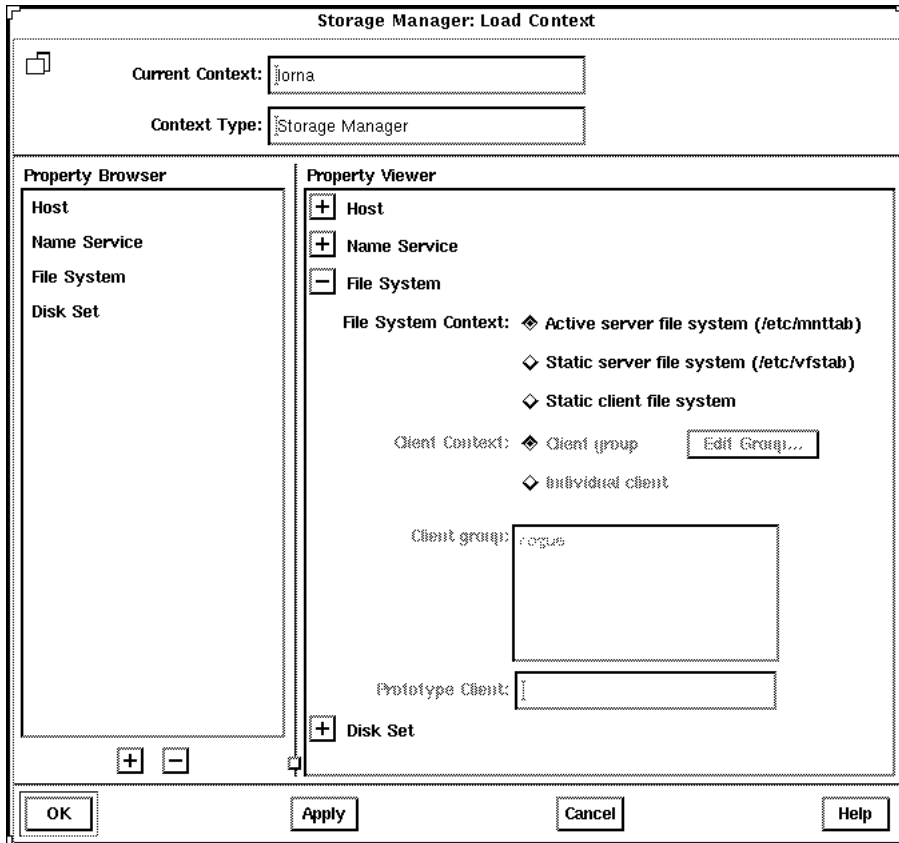

### ▼ How to View Static Server File Systems

*Static server file systems* are the file systems on a server that will be mounted or shared at boot time. This is the same information as contained in the `/etc/vfstab` file and `/etc/dfs/dfstab` file.

1. **Click on the Load Context icon or choose Load from the File menu.**  
The Load Context property book is displayed.
2. **Open the File System chapter, if not done already.**

3. Click on the Static Server File System Button.

4. Click on OK.

The file systems that will be mounted at boot time on the server are displayed in the Mount Point list on the main window.

The directories that will be shared at boot time on the server are displayed in the Shared Resources list on the main window.

## Example of Viewing Static Server File Systems

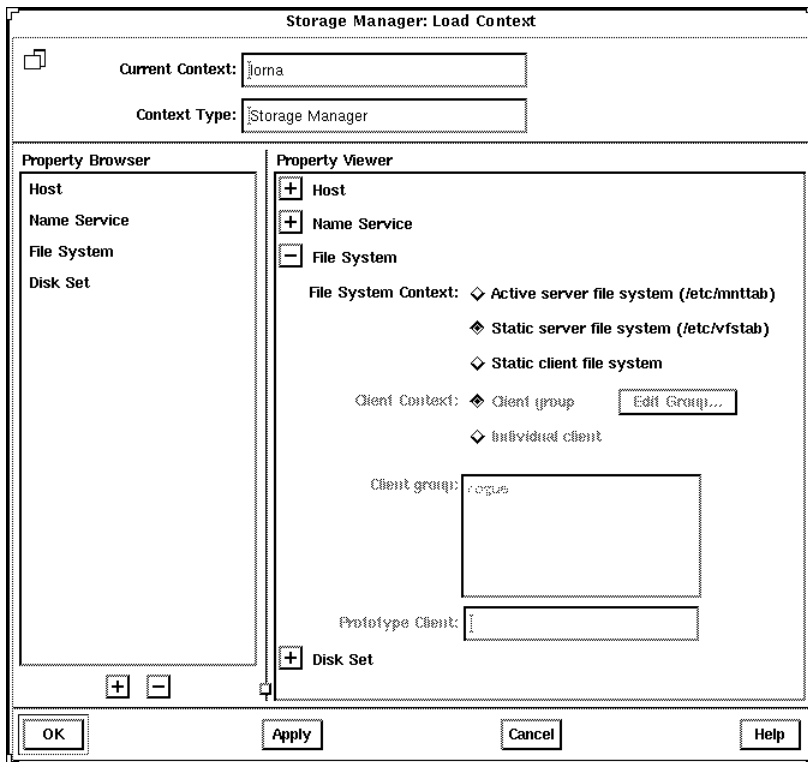

### ▼ How to Remove a Mount Point From the /etc/vfstab File

1. Perform the procedures in "How to View Static Server File Systems" on page 197.
2. Select a mount point from the main browser, Mount Point list, or Shared Resource list.

3. **Choose Properties from the Object menu.**  
The property book for the file system is displayed.
4. **Open the Mount Options chapter.**
5. **Open the Basic subchapter.**
6. **Click on Vfstab Entry.**  
You are toggling (deselecting) this property.
7. **Click on OK.**  
The mount point no longer appears in the Mount Point list.

### Example of Removing a Mount Point Entry From the /etc/vfstab File

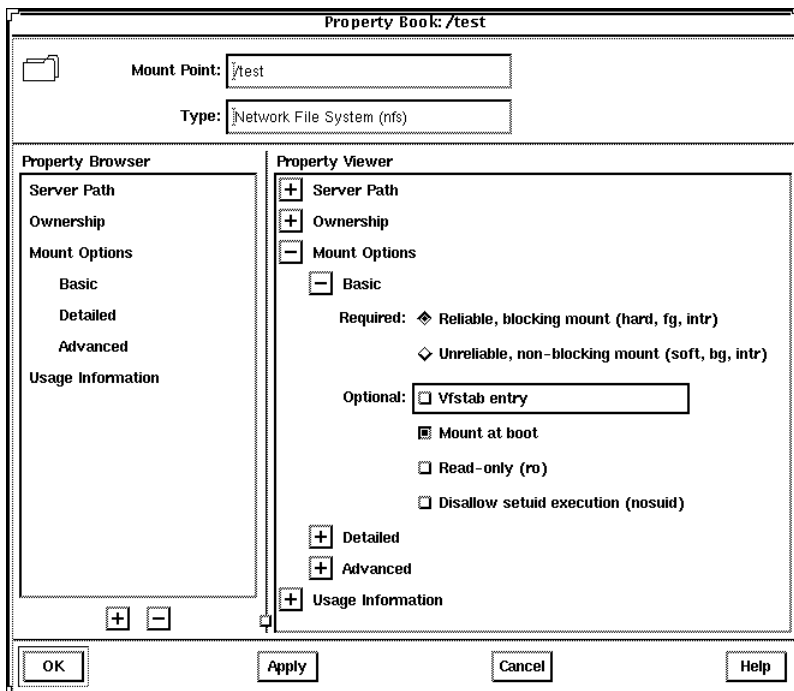

---

## Disk Manager Overview

Disk Manager is a tool that enables you to view and edit `fdisk` partitions and slices using two types of windows, the main window and a Property Book. The main window displays the controllers, targets, disks, and slices for the current context. The Property Book displays the chapters and their properties for the selected disk(s), and it is at this level that you can view and edit disk properties.

Specifically, you can complete the following tasks with Disk Manager.

- Assign a volume name to a disk.
- View and modify `fdisk` partitions on x86 platforms.
- Show and set the active `fdisk` partition on x86 platforms.
- View and modify slice geometry on SPARC and x86 platforms.
- Copy a disk's characteristics to one or more disks of the same type.

---

**Note** - Before modifying `fdisk` partitions and slices, you might want to back up critical data.

---

For step-by-step instructions on how to complete these tasks, refer to Table 11-2. Also, these instructions are included in the online help provided with the Disk Manager tool.

---

## Disk Manager's Main Window

Figure 11-4 shows the important areas of the Disk Manager's main window.



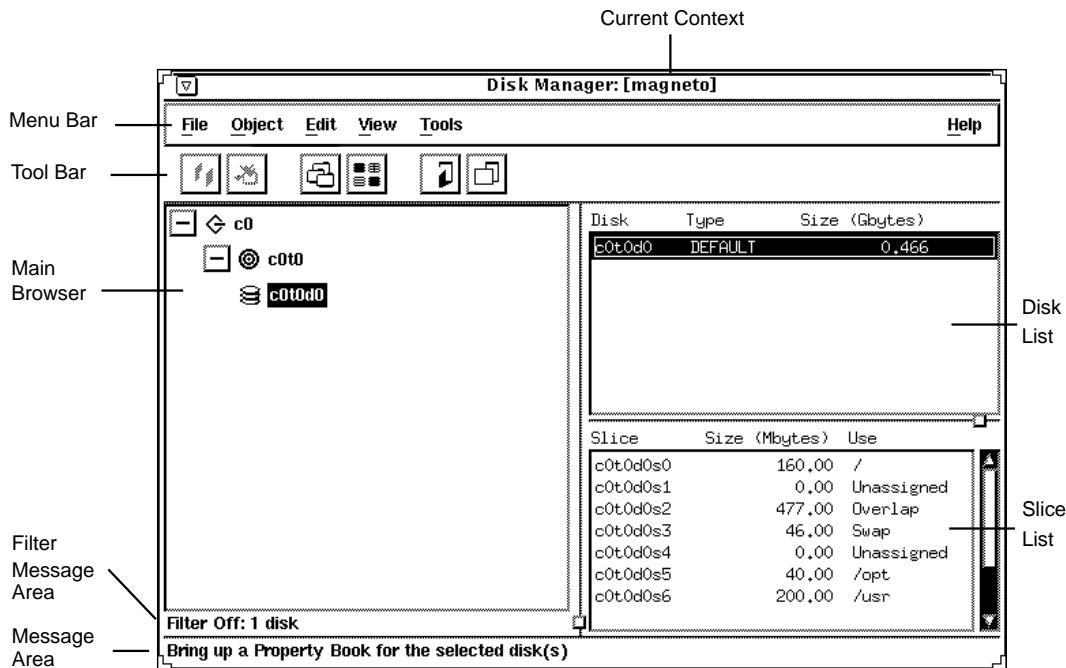

Figure 11-4 Disk Manager's Main Window

Here are some brief descriptions of the areas within Disk Manager's main window:

- **Current Context** – Specifies the server where you are managing disks. You can change the current context by choosing Load from the File menu or by clicking on the Load Context icon in the tool bar.
- **Menu Bar** – Displays the menus that enable you to perform operations in Disk Manager. For detailed descriptions of the menus, see online help.
- **Tool Bar** – Displays icons that provide an easier way to select commonly-used operations provided by the main menu, such as cutting, pasting, and launching other tools. When you move the mouse pointer over an active icon, the message area describes what operation the icon will perform. You can choose Toolbar from the View menu to turn the tool bar off or on (by default, it is turned on).
- **Main Browser** – Displays a hierarchical view of the disk controllers, SCSI targets, and disks for the current system context. You can use the expand/collapse buttons to expand or collapse the view of the SCSI targets and disks under each disk controller. The main browser initially displays the disk controllers for all the available disks in the current context, in their collapsed state.
- **The + and - Buttons** – Are three state buttons that are used to expand and collapse the hierarchical structure you are viewing. The three states are:
  - Collapsed all (the + is displayed)
  - Collapsed managed objects (the +/- is displayed)
  - Expanded all (the - is displayed)

The +/- state means that the corresponding entry is only partially expanded or collapsed. Clicking on a button in this state will further expand the entry.

- Filter Message Area – Displays whether a filter is on or off, and if a filter is on, how many disks are filtered.
- Message Area – Provides information about the main window or icon where the mouse pointer is located.
- Disk List – Displays the type and size information for the disk(s) currently selected in the main browser.
- Slice List – Displays the slices and their sizes for the disk(s) currently selected in the disk list.

## Selecting Multiple Disks

If you have multiple disks that are the same vendor type and have the same physical geometry, you can perform an operation on them simultaneously. This is called *batch editing* or *batching*. To select more than one disk in the main browser or disk list, click SELECT (by default, the left mouse button) on the first disk. Then select each subsequent disk by pressing the Shift key and clicking SELECT.

---

## Disk Manager Property Book

There are three ways to open the Disk Manager Property Book.

- Select one or more disks in the main browser and choose Properties from the Object menu.
- Select one or more disks in the main browser and click on the Property Book icon in the tool bar.
- Double-click on a disk in the main browser.

Figure 11-5 shows the important features of the Disk Manager Property Book.

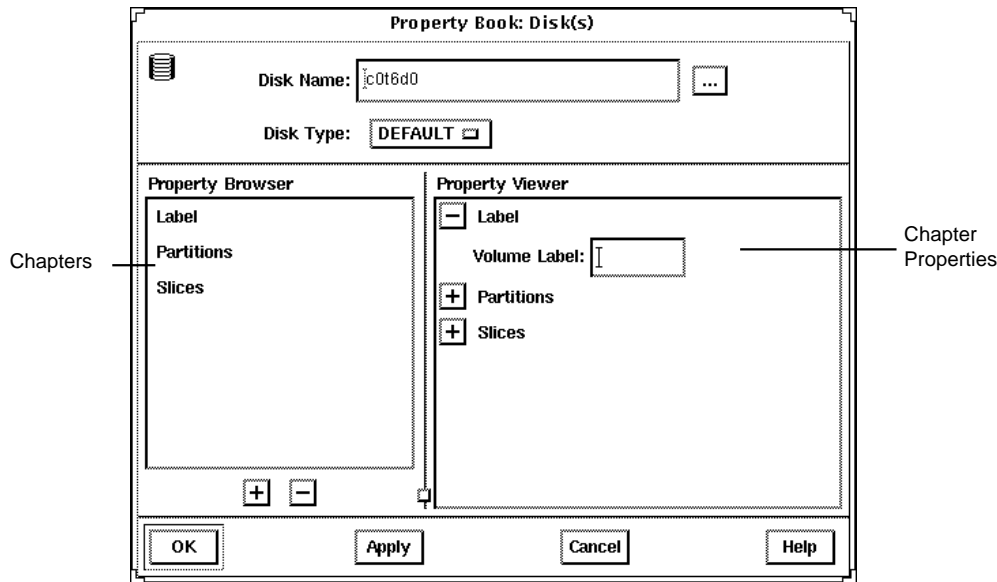

Figure 11-5 Disk Manager Property Book

Here are some brief descriptions of the areas within Disk Manager's main window:

- **Disk Name** – Specifies the object or group of objects that you can manage in the property book. In Figure 11-5, the object is a disk whose name is `c0t6d0`.
- **The ... Button** – Indicates that there is at least one other disk of the same type as the disk being edited on the system. Clicking on the ... button displays the Choose Disks to Edit window. This allows you to select more than one disk (of the same type) for simultaneous edit operations.
- **Disk Type** – Specifies the type of the object. In Figure 11-5, the object is a disk that has a disk type of DEFAULT.
- **Property Browser** – Functions much the same way as the Storage Manager Load Context Property Browser. It lists all the chapters or subchapters (if any) for the selected disk(s).

Double-clicking on a chapter expands the chapter in the Property Viewer and displays the subchapters (if any) or the object properties.

- **Chapters** – Contains a common set of properties for the object that you can view or modify.
- **The + and - Buttons** – The buttons that appear below the Property Browser perform an expand all (+) or collapse all (-) function on the chapters in the Property Viewer. This is a quick way of viewing all chapter properties or only the chapter names.

The buttons that appear next to chapter names in property books also perform an expand all or collapse all function, but only on the selected chapter.

- Property Viewer – Enables you to expand and collapse the contents of chapters. You can expand a chapter down to its object properties, enabling you to view or modify the property for the object.
- Chapter Properties – Specifies the properties that you can view or modify for the object. There can be one or more properties in a chapter. In Figure 11–5, the Label chapter has a Volume Label field that provides a way to assign a name to a disk.

For more reference information on the chapters that are available from the Disk Manager Property Book, see online help.

---

## Managing Disks With Disk Manager

TABLE 11–2 Task Map: Managing Disks With Disk Manager

Activity	Description	For Instructions, Go To
Specify a Viewing Filter	Specify the attributes of the disk(s) that you want to view in the Disk Manager main browser.	“How to Specify a Viewing Filter” on page 205
Specify a Volume Label	Assign a name to a disk.	“How to Specify a Volume Label” on page 206
Modify <code>fdisk</code> Partitions	Select an active <code>fdisk</code> partition, modify <code>fdisk</code> partition sizes, and/or modify the type of <code>fdisk</code> partitions.	“How to Modify <code>fdisk</code> Partitions” on page 207
Modify Slice Geometry	Modify slice sizes.	“How to Modify Slice Geometry” on page 208
Clone a Disk	Copy a disk’s characteristics onto other disks of the same type.	“How to Clone a Disk” on page 209

## ▼ How to Specify a Viewing Filter

### 1. Choose Filter from the View menu.

The Filter Disks and Slices window appears with a list of the available disk attributes in the Available Attributes list.

### 2. Specify which disks, with specific disk attributes, you want to display in the main window.

a. Click on a disk attribute in the Available Attributes list.

b. Click on the >> button to move the attribute to the Show Disks list.

c. Repeat Step 2 on page 205 and Step 2 on page 205 until the Show Disks list contains all the disk attributes that disks displayed in the main window will have.

---

**Note** - Clicking on the All >> button, moves the entire list of attributes in the Available Attributes list to the Show Disks list. Clicking on the All << button, moves the entire list of attributes in the Show Disks list to the Available Attributes list.

---

### 3. Click on OK.

The main window refreshes, displaying only the disks that match the criteria specified in the Show Disks list. The message area below the main browser displays the number of filtered disks.

## Example of a Filter Disks and Slices Window

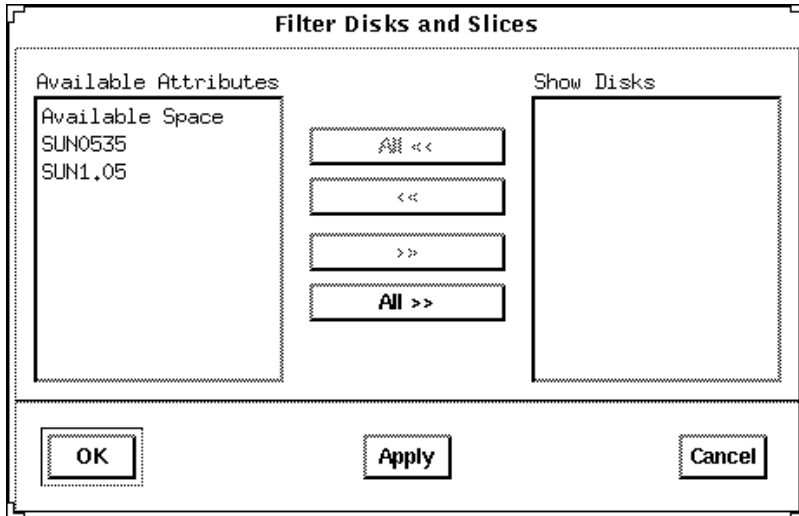

The Available Attributes section contains an entry for each disk type present in the current context, and an entry called “Available Space” that corresponds to all disks and slices with free space. The Show Disks section lists the attributes of the disks displayed in the main window. By default, this section is empty because filtering is turned off.

### ▼ How to Specify a Volume Label

1. **Select the disk that you want to modify in the Disk Manager main browser.**
2. **Open the Property Book for the selected disk.**  
For more information see “Disk Manager Property Book” on page 202.  
The Property Book window appears.
3. **Open the Label chapter.**  
For more information see “Disk Manager Property Book” on page 202.
4. **Delete the existing name in the Volume Label field, if applicable.**
5. **Enter the name of the volume label, which must be an alphanumeric string of 8 or fewer characters.**
6. **Click on OK.**

## Example of Specifying a Volume Label

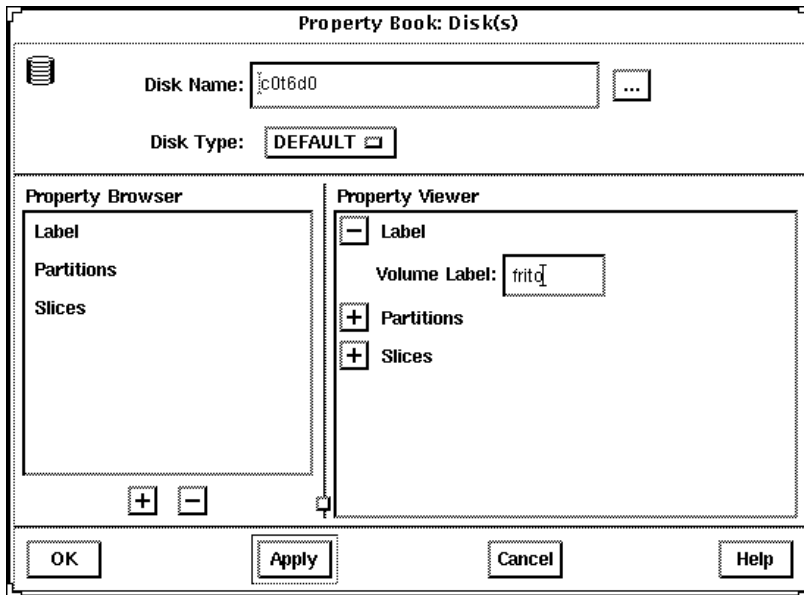

### ▼ How to Modify `fdisk` Partitions

1. Select the disk that you want to modify in the Disk Manager main browser.
2. Open the Property Book for the selected disk.  
For more information see “Disk Manager Property Book” on page 202.  
The Property Book window appears.
3. Open the Partitions chapter.  
For more information see “Disk Manager Property Book” on page 202.  
Size the Property Book window so that the entire partition layout is visible.
4. Click on the select box in the Editable column that corresponds to the `fdisk` partition you want to edit.
5. Modify the size of an `fdisk` partition(s) by clicking on the arrows in the Slider portion of the window, or click on the appropriate Start or End field in the Partition Data portion of the window, type in a value, and press Return.  
For reference information, see online help.

---

**Note** - For x86 platforms, `fdisk` Solaris partitions must start at cylinder 1 or higher and they may not overlap.

---

6. If desired, select the button in the Boot column to make the `fdisk` partition active (the one whose operating system will be used at system start-up).
7. Choose the type of the `fdisk` partition.  
Choose the appropriate type using the menus in the Type column.
8. Click on OK.

## Example of Modifying `fdisk` Partitions

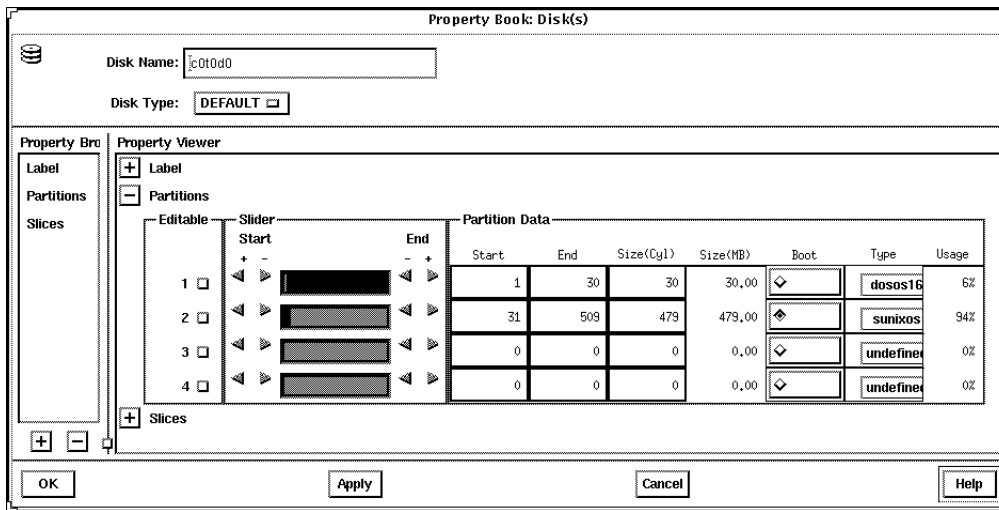

### ▼ How to Modify Slice Geometry

1. Select the disk that you want to modify in the Disk Manager main browser.
2. Open the Property Book for the selected disk.  
For more information see "Disk Manager Property Book" on page 202.  
The Property Book window appears.
3. Open the Slices chapter.  
For more information see "Disk Manager Property Book" on page 202.  
Size the Property Book window so that the entire slice layout is visible.



- Click on the select box in the Editable column that corresponds to the slice you want to edit.
- Modify the size of a slice(s) by clicking on the arrows in the Slider portion of the window, dragging the bar indicators, or typing values in the Start and End fields.

For reference information, see online help.

---

**Note** - For x86 platforms, slices must start at cylinder 1 or higher and may not overlap.

---

- Click on OK.

## Example of Modifying Slice Geometry

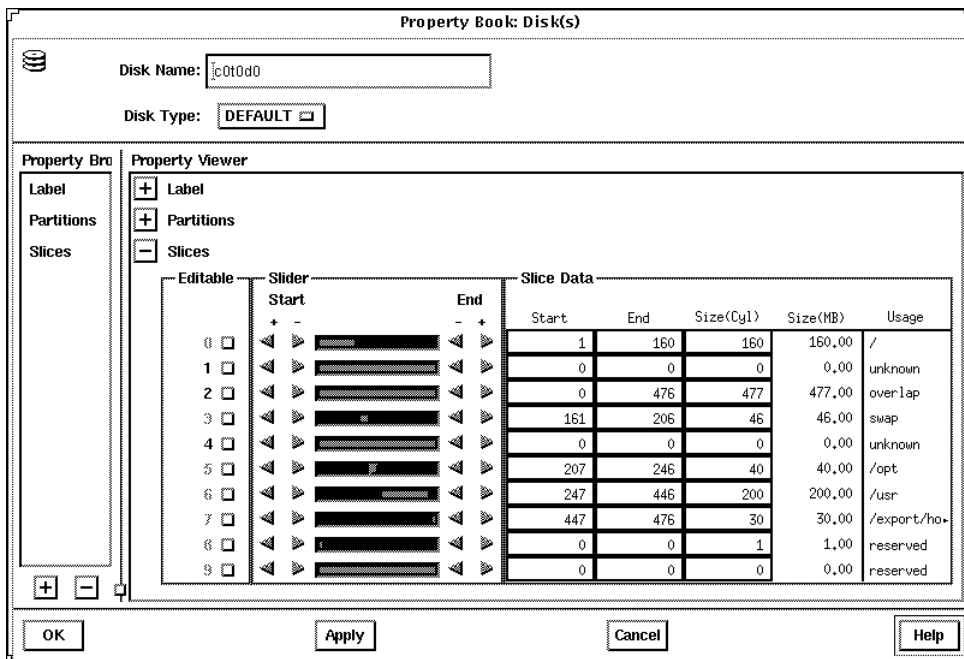

## ▼ How to Clone a Disk

- Select the disk you want to clone in the Disk Manager main browser.
- Click on the copy icon in the tool bar or choose Copy from the Edit menu.

3. **Select a unused disk of the same type, or select a controller containing one or more unused disks of the same type, in the Disk Manager main browser.**
4. **Click on the paste icon in the tool bar, or choose Paste from the Edit menu.**

---

**Note** - An alternate method to performing the tasks described in Step 2 on page 209 to Step 4 on page 210 is to press ADJUST (by default the middle mouse key) over the disk you want to copy, drag the cursor onto the disk of the same type, and release the ADJUST button.

---

# Additional Solstice AdminSuite Administration

---

This part provides information on additional administration that you may need to do after using the Solstice AdminSuite software, and additional administration that the Solstice AdminSuite software provides.

**Chapter 12**

*Booting a System From the Network* provides instructions on how to manually boot your diskless clients from the network and how to set them up to automatically boot from the network.

**Chapter 13**

*Monitoring Software Usage* provides overview information and instructions on how to use a compilation of software programs that enable you to monitor software usage in a server/client environment or on a non-networked system.



## Booting a System From the Network

---

After you add a diskless client (see “How to Add Support for a Diskless Client” on page 100) to a server, the system is ready to boot and run the Solaris environment.

---

**Note** - Diskless clients must always boot from the network.

---

This is a list of the step-by-step instructions in this chapter.

- “SPARC: How to Manually Boot a System From the Network” on page 215
- “SPARC: How to Manually Boot a Sun-4 System From the Network” on page 216
- “SPARC: How to Set Up a System to Automatically Boot From the Network” on page 217
- “SPARC: How to Set Up a Sun-4/3*nn* System to Automatically Boot From the Network” on page 219
- “SPARC: How to Set Up a Sun-4/1*nn*, 2*nn*, or 4*nn* System to Automatically Boot From the Network” on page 220
- “x86: How to Manually Boot a System” on page 222
- “x86: How to Set Up a System to Automatically Boot From the Network” on page 223

---

## SPARC: Booting From the Network

This section provides procedures on how to manually boot your SPARC system from the network, and how to set it up to automatically boot from the network.

You need to read only certain portions of this section. Table 12-1 shows you which task information to read for the type of systems you have on your network.

**TABLE 12-1** System Booting Information

If You Have This System ...	See These Tasks ...	On ...
SPARCstation and above with the Solaris software already running (boot prom prompt) or out of the box (the ok prompt)	<p>“SPARC: How to Manually Boot a System From the Network” on page 215</p> <p>“SPARC: How to Set Up a System to Automatically Boot From the Network” on page 217</p>	<p>“SPARC: How to Manually Boot a System From the Network” on page 215</p> <p>“SPARC: How to Set Up a System to Automatically Boot From the Network” on page 217</p>
Sun-4 systems	<p>“SPARC: How to Manually Boot a Sun-4 System From the Network” on page 216</p> <p>“SPARC: How to Set Up a Sun-4/3nn System to Automatically Boot From the Network” on page 219”</p> <p>“SPARC: How to Set Up a Sun-4/1nn, 2nn, or 4nn System to Automatically Boot From the Network” on page 220</p>	<p>“SPARC: How to Manually Boot a Sun-4 System From the Network” on page 216</p> <p>“SPARC: How to Set Up a Sun-4/3nn System to Automatically Boot From the Network” on page 219</p> <p>“SPARC: How to Set Up a Sun-4/1nn, 2nn, or 4nn System to Automatically Boot From the Network” on page 220</p>

---

**Note** - In the Solaris 2.5 environment, only the Sun-4c, Sun-4d, Sun-4m, Sun-4u kernel architectures, and the x86 platforms are supported. The Solaris 2.5 software no longer supports Sun-4 and Sun-4e.

---

Table 12-2 summarizes the commands you use to manually boot systems from the network for different system models.

TABLE 12-2 Sun System Boot Commands

System Type	Boot Command
SPARCstation and above	<code>boot net</code>
Sun-4/3nn	<code>b le()</code>
Sun-4/1nn, Sun-4/2nn, Sun-4/4nn	<code>b ie()</code>

For more information about the booting process in general, see the Solaris 2.4 Administration Supplement for Solaris Platforms for the Solaris 2.4 product, and the *System Administration Guide, Volume I* for the Solaris 2.5 product.

## ▼ SPARC: How to Manually Boot a System From the Network

**Note** - If you want to manually boot a Sun-4 system from the network, see “SPARC: How to Manually Boot a Sun-4 System From the Network” on page 216.

- 1. Make sure the diskless client has been set up as described in “How to Add Support for a Diskless Client” on page 100.**
- 2. Make sure the system is in the prom monitor environment.**  
If the system is not running, power it up. If the system is currently running, use the `init 0` command to get it to the boot prom prompt.
- 3. If the screen displays the `>` prompt instead of the `ok` prompt, type `n` and press Return or Enter.**  
The screen should now display the `ok` prompt. If not, see “SPARC: How to Manually Boot a Sun-4 System From the Network” on page 216.
- 4. Boot the system from the network.**

```
ok boot net
```

## Example of Manually Booting a SPARC System From the Network

```
# init 0
> n
ok
.
.
.
ok boot net
Booting from: le(0,0,0)
2bc00 hostname: pluto
domainname: Solar.COM
root server:
root directory: /export/root/pluto
SunOS Release 5.4 Version [2.4_FCS] [UNIX(R) System V Release
4.0]
Copyright (c) 1983-1994, Sun Microsystems, Inc.
configuring network interfaces: le0.
Hostname: pluto
Configuring cache and swap:.....done.
The system is coming up. Please wait.
NIS domainname is Solar.COM
starting rpc services: rpcbind keyserver ypbind kerbd done.
Setting netmask of le0 to 255.255.255.0
Setting default interface for multicast: add net 224.0.0.0:
gateway pluto
syslog service starting.
Print services started.
volume management starting.
The system is ready.
login: root
password:
# exit
```

### ▼ SPARC: How to Manually Boot a Sun-4 System From the Network

- 1. Make sure the diskless client has been set up as described in “How to Add Support for a Diskless Client” on page 100.**
- 2. Make sure the system is in the prom monitor environment.**  
If the system is not running, power it up. If the system is currently running, use the `init 0` command to get it to the boot prom prompt.
- 3. Type the appropriate boot command to boot the system from the network.**



```
> b ie()  
or  
> b ie()
```

## ▼ SPARC: How to Set Up a System to Automatically Boot From the Network

---

**Note** - If you want to set up a Sun-4 system to automatically boot from the network, see “SPARC: How to Set Up a Sun-4/3nn System to Automatically Boot From the Network” on page 219, or “SPARC: How to Set Up a Sun-4/1nn, 2nn, or 4nn System to Automatically Boot From the Network” on page 220.

---

1. **Make sure the diskless client has been set up as described in “How to Add Support for a Diskless Client” on page 100.**
2. **Make sure the system is in the prom monitor environment.**  
If the system is not running, power it up. If the system is currently running, use the `init 0` command to get it to the boot prom prompt.
3. **If the screen displays the `>` prompt instead of the `ok` prompt, type `n` and press Return or Enter.**  
The screen should now display the `ok` prompt. If not, see “SPARC: How to Set Up a Sun-4/3nn System to Automatically Boot From the Network” on page 219, or “SPARC: How to Set Up a Sun-4/1nn, 2nn, or 4nn System to Automatically Boot From the Network” on page 220.
4. **Determine the version number of the boot prom with the `banner` command. The following is an example:**

```
ok banner  
SPARCstation 2, Type 4 Keyboard  
  
ROM Rev. 2.0, 16MB memory installed, Serial # 289  
Ethernet address 8:0:20:d:e2:7b, Host ID: 55000121
```

5. **Set the boot device.**

If the boot prom is version 2.0 or greater, type the following command.

```
ok setenv boot-device net
boot-device=net
```

If the boot prom version is less than 2.0, type the following command.

```
ok setenv boot-from net
```

For more information about boot prompts, see the OpenBoot 2.x Command Reference Manual or the OpenBoot 3.x Command Reference Manual.

**6. Boot the system automatically from the network by using the `boot` command.**

```
ok boot
```

## ▼ SPARC: How to Display Existing Boot Device Values on Sun-4 Systems

This procedure describes how to display the current boot device values, if you need to record them before changing them.

**1. Display the values of the system's current booting devices.**

```
> q18
```

The system displays the first EEPROM value.

**2. Write down the EEPROM number and value.**

For example, you might see `EEPROM 018:12?`. The EEPROM number is 018 and the value is 12.

**3. Press Return to display the next value.**

**4. Repeat steps 2 and 3 until the last value is displayed.**

The last value is 00.

**5. Quit the EEPROM display mode.**

```
EEPROM 01B: 00? q
```

## Example of Displaying Existing Boot Device Values on Sun-4 Systems

```
> q18
EEPROM 018: 12?
EEPROM 019: 69?
EEPROM 01A: 65?
EEPROM 01B: 00? q
>
```

Entering `q18` and pressing Return three times displays the three values. You should retain this information. The last `q` entry returns you to the `>` prompt.

### ▼ SPARC: How to Set Up a Sun-4/3nn System to Automatically Boot From the Network

1. Make sure the diskless client has been set up as described in “How to Add Support for a Diskless Client” on page 100.
2. Make sure the system is in the prom monitor environment.
3. (Optional) Perform the procedures in “SPARC: How to Display Existing Boot Device Values on Sun-4 Systems” on page 218 if you want to record the current boot device values.
4. At the command prompt, enter the following boot device code sequence.

```
> q18 12 6c 65
```

This is the code for `1e` (the Lance Ethernet).

What you are doing for any of the Sun-4 architectures is programming the EEPROM (or NVRAM) by entering `q` followed by the hexadecimal address in the EEPROM. This sets the appropriate operating system boot device.

5. Boot the system automatically from the network.

```
> b
```

## Example of Setting Up a Sun-4/3nn System to Automatically Boot From the Network

```
> q18 12 6c 65
EEPROM 018 -> 12
EEPROM 019 -> 6C
EEPROM 01A -> 65
>
```

If the system output looks like the example above, you set the codes successfully. If the output looks similar to the following:

```
> b
EEPROM boot device... ie(0,0,0)
Invalid device = 'ie'
```

you set the wrong code for the specific system architecture, and the system will not boot. You need to reset the codes. In the above example output, a Sun-4/3nn was set up with the wrong device code (*ie* instead of *1e*).

### ▼ SPARC: How to Set Up a Sun-4/1nn, 2nn, or 4nn System to Automatically Boot From the Network

1. **Make sure the diskless client has been set up as described in “How to Add Support for a Diskless Client” on page 100.**
2. **Make sure the system is in the prom monitor environment.**
3. **(Optional) Perform the procedures in “SPARC: How to Display Existing Boot Device Values on Sun-4 Systems” on page 218 if you want to record the existing boot device values.**
4. **At the command prompt, enter the following boot device code sequence.**

```
> q18 12 69 65
```

This is the code for *ie* (the Intel Ethernet).

What you are doing for any of the Sun-4 architectures is programming the EEPROM (or NVRAM) by entering *q* followed by the hexadecimal address in the EEPROM. This sets the appropriate operating system boot device.

5. **Boot the system automatically from the network.**

```
> b
```

## Example of Setting Up a Sun-4/1nn, 2nn, or 4nn System to Automatically Boot From the Network

```
> ql8 12 69 65
EEPROM 018 -> 12
EEPROM 019 -> 69
EEPROM 01A -> 65
```

If the system output looks like the example above, you set the codes successfully. If the output looks similar to the following:

```
> b
EEPROM boot device... le(0,0,0)
Invalid device = 'le'
```

you set the wrong code for the specific system architecture, and the system will not boot. You need to reset the codes. In the above example output, a Sun-4/1nn, 2nn, or 4nn was set up with the wrong device code (le instead of ie).

---

## x86: Booting From the Network

The following procedures apply to x86 systems. Booting an x86 system uses these two subsystems:

- Solaris boot diskette (contains the program that provides booting from the network)
- Secondary boot subsystem

The Solaris boot diskette, also known as the MDB diskette, provides a menu of bootable devices such as disk, network, or CD-ROM. (The system probes currently connected devices and displays the devices in the MDB menu.) Diskless clients must boot from the network so you would always enter the code for the network device.

The second boot subsystem menu displays available boot options. The system automatically boots to run level 3 if you do not select an option within 60 seconds. The other options enable you to specify boot options or enter the boot interpreter (see `boot(1M)`).

## ▼ x86: How to Manually Boot a System

This procedure describes how to manually boot your x86 system from the network. Screen displays will vary based on system configurations.

1. **Make sure the diskless client has been set up as described in “How to Add Support for a Diskless Client” on page 100.**
2. **Insert the Solaris boot diskette into the drive.**
3. **Press the reset button.**

The Primary Boot Subsystem menu is displayed after a short time.

```
Solaris 2.4 for x86                               Multiple Device Boot, vsn 2.1

Solaris/x86 Multiple Device Boot Menu

Code  Device    Vendor    Model/Desc    Rev
=====
10    DISK        MAXTOR    LXT-535S      8.75
11    CD           SONY      CD-ROM CDV-8012  3.1d
12    NET          SMC/WD    I/O=300 IRQ=5
```

The Solaris boot diskette provides a menu of bootable devices such as disk, network, or CD-ROM. (The system probes currently-connected devices and displays the devices in the MDB menu.)

---

**Note** - The number 30 displayed in the bottom left corner counts down, indicating the number of seconds left to set the boot device code. If you do not specify the boot device code within 30 seconds, the system will attempt to boot from the C drive, which is the default device.

---

4. **Enter the boot device code to boot from the network.**

In this example the boot device code is 12.

The Secondary Boot Subsystem menu is displayed after a short time.

```
Solaris 2.4 for x86          Secondary Boot Subsystem,  
vsn 2.11
```

```
<<< Current Boot Parameters >>>
```

```
Boot path: /eisa/dpt@5c88,0/cmdk@0,0:a
```

```
Boot args: /kernel/unix
```

```
Type  b [file-name] [boot-flags] <ENTER>   to boot with options
```

5. Type **b** or **boot** to boot the system and press **Return**.

## ▼ x86: How to Set Up a System to Automatically Boot From the Network

This procedure describes how to create an x86 multiple device boot (MDB) diskette so that your x86 diskless client will always boot from the network—so you do not have to be there to boot it. Otherwise, if the master MDB diskette is inserted into the drive, an x86 system will attempt to boot off the C drive after a power cycle (for more information see “x86: Booting From the Network” on page 221).

---

**Note** - Before following these steps to create an MDB boot diskette, obtain the master MDB diskette for the x86 system and a blank 1.44 Mbyte diskette. The blank diskette will be formatted, so do not use a diskette with data on it.

---

1. **Become root on your server.**
2. **Change your working directory.**

```
# cd /opt/SUNWadm/2.3/floppy
```

3. **++**

Create the MDB boot diskette.

```
# ./mk_floppy
```

The script prompts you when to insert the MDB master diskette and the blank diskette, and provides additional status information.

```
Please insert the master MDB floppy and press Return:  
Please insert a blank floppy and press Return:
```

```
Formatting 1.44 MB in /dev/rdiskette
.....
.....
fdformat: using "./mboot" for MS-DOS boot loader
Successfully created the AutoClient floppy.
#
```

---

**Note** - Even though the script says that it created an AutoClient floppy, you can also use this floppy on diskless x86 systems.

---

- 4. Insert the MDB boot diskette into the diskette drive of the x86 system.**  
You must leave this boot diskette in the diskette drive so that the system will automatically boot from the network if a power cycle occurs.



## Monitoring Software Usage

---

The following is a list of the overview information in this chapter.

- “What Is Software Usage Monitoring” on page 226
- “What Can Software Usage Monitoring Do” on page 226
- “How Can Software Usage Monitoring Be Used” on page 227
- “How Software Usage Monitoring Works” on page 228
- “Before Using Software Usage Monitoring” on page 231
- “Generating Software Usage Report Entries” on page 234
- “Transferring Software Usage Entries on a Client to the Master Log File on the Software Usage Monitoring Server” on page 245
- “Printing Software Usage Data from the Master Log File” on page 247
- “Removing the Master Log File” on page 251

The following is a list of the step-by-step instructions in this chapter.

- “How to Verify Software Usage Monitoring Has Been Installed on a Software Usage Monitoring Server” on page 231
- “How to Verify That Software Usage Monitoring Is Installed and Enabled on a Client” on page 232
- “How to Verify that Software Usage Monitoring is Enabled on a Host in a Shared File System Environment” on page 233
- “How to Stop the `swu_svr` Daemon” on page 234
- “How to Start the `swu_svr` Daemon” on page 233
- “How to Monitor Software Usage Using a Command-Line Interface” on page 235
- “How to Monitor Software Usage Using a Shell Script Wrapper” on page 238
- “How to Add Software Usage Monitoring to a Shell Script Program Executable Command Line” on page 240

- “How to Embed Software Usage Monitoring into Applications” on page 242
- “How to Transfer Software Usage Entries on the Client to the Master Log File on the Software Usage Monitoring Server” on page 247
- “How to Print Software Usage Data from the Master Log File” on page 250
- “How to Remove the Master Log File” on page 251

---

## What Is Software Usage Monitoring

Software usage monitoring is a compilation of software programs that enable you to monitor software usage in your computer system. The software usage monitoring system tracks the software usage and installations across network servers and workstations, to simplify system administration and purchasing decisions. For example, after using software usage monitoring, you may find that some software is never used while other software may be used repeatedly and needs additional licenses. In addition, you may find that a piece of software is installed on a workstation and is never used; this software could be used by another user who needs it.

The software usage monitoring system is not intended to be a licensing manager, nor does it track all software usage on your computer system. The software usage monitoring system functions as a push system rather than a pull system. That is, the software monitoring system cannot randomly obtain usage information from your computer system. Software running on your computer system must push usage information to the software usage monitoring server.

---

## What Can Software Usage Monitoring Do

Software usage monitoring can do three basic tasks:

- It generates software usage information (report entries).
- It transfers report entries from the client (local queue) to the software usage monitoring server.
- It formats and prints software report entries.

Software usage monitoring accomplishes these tasks using commands which are listed and described in Table 13-1.

---

**Note** - Refer to the man pages for detailed descriptions of the commands.

---

TABLE 13-1 Software Usage Monitoring Commands

Command	Description
<code>swu_rpt</code> (command or function)	Creates a software usage entry and places it into the local queue ( <code>/var/opt/SUNWswusg/swusage</code> ) on the client or the master log file on the software usage monitoring server ( <code>/var/opt/SUNWswusg/swusage.log</code> )
<code>swu_queue</code> command	Moves the software report entries in the local queue ( <code>/var/opt/SUNWswusg/swusage</code> ) to the software usage monitoring server; also enables and disables the local queue
<code>swu_svr</code> command	Software usage monitoring daemon which receives software usage reports sent by the <code>swu_queue</code> command from the client or by <code>swu_rpt</code> function
<code>swu_print</code> command	Formats and prints usage information in the master log file ( <code>/var/opt/SUNWswusg/swusage.log</code> ) to <code>stdout</code> or another file

---

## How Can Software Usage Monitoring Be Used

To generate software usage entries, you must run the `swu_rpt` command or function with your software applications. You can accomplish this by using any of the following:

- You can use the `swu_rpt` command from the command line. The command line method enables you to start an application program and create a software usage entry. For example, if you want to start the `FrameMaker` program and create a software usage entry, you can do this at a command line.
- You can use the `swu_rpt` command in a shell script. The shell script method enables you to add the `swu_rpt` command into an existing shell script. For example, you may have a shell script called “`frame`” used to start the `FrameMaker` program. You can create a shell script wrapper by editing the `frame` script. Within

this script, you can add the `swu_rpt` command before and after the script's program executable. Thus, you wrap the program executable with `swu_rpt` commands. This creates a Begin and End software usage entry each time the script is run. In addition to the shell script wrapper method, you can modify the shell script executable command line to include the `swu_rpt` command using the `-c` option, which will create a Begin and an End entry each time the script is run.

---

**Note** - The end record may not be accurate if the command returns after spawning a new process (for example, in the background).

---

- You can embed calls to the `swu_rpt()` function in an application. The embedded application method enables you to add a call to the software usage library into your application source code. For example, if you or someone else on your computer network has created an application, you can call the software usage library from this application. This causes software usage entries to be created each time the application is run.

---

**Note** - To use the embedded application method, you must have access to the application's source code.

---

How to implement these methods is described in detail in "Generating Software Usage Report Entries" on page 234.

---

## How Software Usage Monitoring Works

The software usage monitoring system can be used in a client/server environment or in a shared file system environment. Software usage monitoring operates differently, depending upon which environment it is run. The following sections describe how software usage monitoring operates in each environment.

### Software Usage Monitoring in a Client/Server Environment

Figure 13-1 shows an illustration of the software usage monitoring sequence of events when used in a client/server environment.

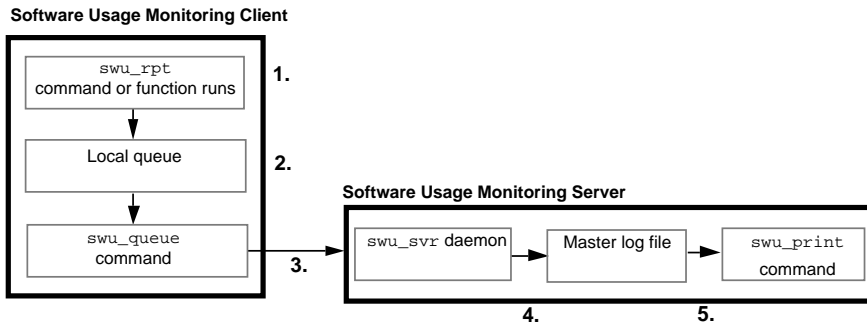

Figure 13-1 Software Usage Monitoring Sequence Of Events (Client/Server)

---

**Note** - The client may also act as a software usage server in that it may have the `swu_svr` daemon, master log file, and `swu_print` command installed on the client.

---

The following list describes the sequence of events.

1. The `swu_rpt` command or function is initiated on the software usage monitoring server or client from a command line, shell script, or within an application.
2. The `swu_rpt` command or function then creates a software usage report entry in the local queue for the associated program. (The type of entry depends upon the options used with the `swu_rpt` command or function.)

---

**Note** - If the local queue has been disabled, no report entries will be logged.

---

3. A cron job (run from root's crontab) using the `swu_queue` command runs on the client or server that transfers (flushes) information in the local queue to the `swu_svr` daemon that is running on the software usage monitoring server.

---

**Note** - Files can be transferred manually by a root user from the local queue to the `swu_svr` daemon using the `swu_queue` command using the `-F` option.

---

4. The `swu_svr` daemon accepts incoming report entries from the `swu_queue` command and saves it to the master log file (`/var/opt/SUNWswusg/swusage.log`) or the log file name specified when the `swu_svr` daemon was started by root on the software usage monitoring server.

---

**Note** - If the `swu_svr` daemon is not running on the software usage monitoring server specified in the entry, that entry in the local queue is removed from the queue.

---

5. The `swu_print` command takes information in the master log file (`/var/opt/SUNWswusg/swusage.log`) or the specified log file name and copies all, part, or a summary of the information to another file where the information can be searched using `awk` or other search tool. By default, this command sends it to the standard output device if no file is specified.

---

**Note** - This sequence of events shows the order in which commands are run; however, you should note that the `swu_rpt` command or function could be run numerous times before the `swu_queue` command transfers software usage report entries from the local queue.

---

## Software Usage Monitoring in a Shared File System Environment

Software usage monitoring operates in a similar manner in a shared file system environment as it does in a client/server environment. By installing software usage monitoring on a dedicated software usage monitoring server, you can share the binary files with other hosts in your network.

Figure 13-2 shows an illustration of the software usage monitoring sequence of events when used in a shared file system environment.

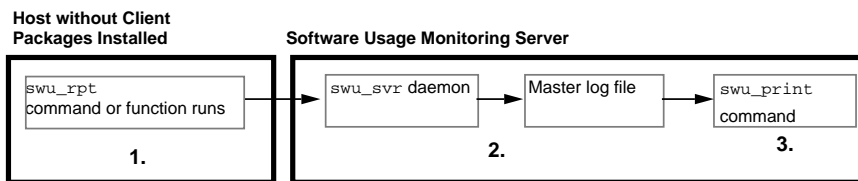

Figure 13-2 Software Usage Monitoring Sequence of Events (Shared File System)

The following list describes the sequence of events.

1. The `swu_rpt` command or function is initiated on a host from a command line, shell script, or within an application.
2. The `swu_svr` daemon receives the information generated from the `swu_rpt` command or function and saves it to the master log file (`/var/opt/SUNWswusg/swusage.log`) or the file name specified when the `swu_svr` daemon was started by root.

---

**Note** - If the `swu_svr` daemon is not running on the host server, the entry is lost.

---

3. The `swu_print` command takes information in the master log file (`/var/opt/SUNWswusg/swusage.log`) or the specified file name and copies all, part, or a summary of the information to another file where the information can be searched using `awk` or other search tool. By default, this command sends it to the standard output device if no file is specified.

---

# Before Using Software Usage Monitoring

Before you use software usage monitoring, you need to complete a number of steps. Usually, these steps only need to be done once; however, it may be necessary to repeat some of them.

The steps required to set up software usage monitoring depend upon the environment in which you intend to run software usage monitoring. The following procedures describe how to set up software usage monitoring on a server and/or a client if you so choose.

## ▼ How to Verify Software Usage Monitoring Has Been Installed on a Software Usage Monitoring Server

1. **Verify that software usage monitoring server side code has been installed on the host server.**

```
$ cd /opt/SUNWswusg/bin
$ ls
swu_print swu_svr
```

If software usage monitoring has not been installed, refer to the Solstice AdminSuite 2.3 Installation and Product Notes for information about installing software usage monitoring.

2. **Verify that the `swu_svr` daemon is running on the host server.**

```
$ ps -ef | /usr/bin/grep swu_svr
root 264 1 0 Jan 04 console 2:43 /opt/SUNWswusg/bin/swu_svr
jod 752 311 1 14:50:16 pts/3 0:00 grep swu_svr
$
```

If the `swu_svr` daemon is not running, start the `swu_svr` daemon. Refer to the “Starting and Stopping the `swu_svr` Daemon” on page 233 that describes how to start and stop the `swu_svr` daemon.

---

**Note** - If you wish to generate software usage monitoring information on a host, the software usage monitoring client binary packages should be installed on that host or should be made available to that host through NFS.

---

## ▼ How to Verify That Software Usage Monitoring Is Installed and Enabled on a Client

1. **Verify that software usage monitoring client code has been installed on the host server.**

```
$ cd /opt/SUNWswusg/bin
$ ls
swu_queue swu_rpt
```

If software usage monitoring has not been installed, refer to the Solstice AdminSuite 2.2 Installation and Product Notes for information about installing software usage monitoring.

2. **Verify that the `swu_queue` is enabled.**

```
$ cd /var/opt/SUNWswusg/swusage
$ ls
$
```

If `queue_disabled` appears after the `ls` command, login as root and enable the queue as shown below.

```
$ ls
queue_disabled
# /opt/SUNWswusg/bin/swu_queue -e
# ls
#
```



## ▼ How to Verify that Software Usage Monitoring is Enabled on a Host in a Shared File System Environment

1. Verify that a software usage monitoring server has been added to the name service.

```
$ rpcinfo -t host 120100
program 120100 version 1 ready and waiting
```

2. Verify that the `swu_rpt` command is executable (through a shared file system or copied locally) by any shell scripts that use it.

---

**Note** - Refer to the *Solstice AdminSuite 2.3 Installation and Product Notes* document for information about how to set up your `swusage_host` server.

---

---

## Starting and Stopping the `swu_svr` Daemon

When software usage monitoring is installed, the `swu_svr` daemon is started on the software usage monitoring server. At times, you may want to stop or restart the `swu_svr` daemon. The following procedures describe how to start and stop this daemon.

### ▼ How to Start the `swu_svr` Daemon

1. Log into the software usage monitoring host server as root.
2. Start the `swu_svr` daemon.

```
# /etc/init.d/swusage start
```

3. **Log out.**

## ▼ How to Stop the `swu_svr` Daemon

1. **Log into the software usage monitoring host server as root.**

2. **Stop the `swu_svr` daemon.**

```
# /etc/init.d/swusage stop
```

3. **Log out.**

---

# Generating Software Usage Report Entries

Software usage monitoring report entries can be generated using the following methods:

- A command line interface
- Shell scripts
- An embedded application

Each method uses the same basic software usage components; however, the methods access the components differently. The following sections describe each method and the procedures used to implement each method.

## Using a Command-Line Interface

The command-line interface method is probably the simplest method of implementing software usage monitoring; however, it can also be the most taxing method as it requires you to manually type in each command each time you run software usage monitoring with an application.

## ▼ How to Monitor Software Usage Using a Command-Line Interface

At the shell prompt, generate a usage report using one of the following `swu_rpt` command lines.

To create a software usage report entry specifying that the associated program has been installed, use the `-i` option.

```
$ swu_rpt -p product-name [-I identifier] [-s server] [-a attr1=val1, attr2=val2,...] \  
-i
```

To create a software usage report entry specifying that the associated program has started, use the `-b` option.

```
$ swu_rpt -p product-name [-I identifier] [-s server] [-a attr1=val1, attr2=val2,...] \  
-b
```

To create a software usage report entry specifying that the associated program has ended, use the `-e` option.

```
$ swu_rpt -p product-name [-I identifier] [-s server] [-a attr1=val1, attr2=val2,...] -e
```

To create software usage report entries specifying a begin and an end entry for the associated program, use the `-c` option.

```
$ swu_rpt -p product-name [-I identifier] [-s server] [-a attr1=val1, attr2=val2,...] \  
-c command
```

In these commands,

<code>-p <i>product-name</i></code>	Indicates the name of the product that software usage is being recorded for; this option must be included.
<code>-I <i>identifier</i></code>	Specifies a numerical identifier for usage records; <code>swu_rpt</code> will provide its own identifier if one is not specified.
<code>-s <i>server</i></code>	Specifies the software usage monitoring server to which the usage records are to be sent. The default is the host aliased to <code>swusage_host</code> .

<code>-a attr1=val1, attr2=val2,...</code>	Allows the user to give the software usage entry unique or more descriptive information.
<code>-b</code>	Indicates that a begin entry will be recorded.
<code>-e</code>	Indicates that an end entry will be recorded.
<code>-i</code>	Indicates that an install entry will be recorded.
<code>-c command</code>	Indicates that the command or program listed after the <code>-c</code> option should be executed and that a begin and end entry should be recorded.

## Example of Monitoring Software Usage Using a Command-Line Interface

The following example shows the software usage monitoring command as used from a command line, which starts the FrameMaker program using the command `maker`, and logs the application using the software usage monitoring `swu_rpt` command.

```
$ swu_rpt -p FrameMaker -I 29581 -s sherlock -c maker
```

In this example, two software usage report entries are created because the `-c` option was used (the `-c` option creates a begin and an end entry). The entries look like the following.

Report Entry 1		Report Entry 2	
Type	Admin/Usage	Type	Admin/Usage
Product	FrameMaker	Product	FrameMaker
SubType	Begin	SubType	End
Time	8444845890	Time	8444845957
UserID	30581	UserID	30581
User	jod	User	jod
Host	buck	Host	buck

Report Entry 1		Report Entry 2	
Domain	forest.field.com	Domain	forest.field.com
HostID	1234567890	HostID	1234567890
Locale	C	Locale	C
Version	1	Version	1
Usage Server	sherlock	Usage Server	sherlock
RecordID	29581	RecordID	29581

## Using Shell Scripts

Another method of monitoring software usage is to create a shell script that initiates a program. This method enables you to create a log entry each time a user executes the shell script. A shell script can be modified using one of two methods: you can create a shell script wrapper, or you can modify the script of an existing shell script program. Either method creates a begin and end software usage monitoring log entry.

- Using the shell script wrapper method, you would enter a software usage monitoring command line before and after the program executable command line. For example, you may have a script called “maker” that starts the FrameMaker™ program. Within this “maker” script, you could add software usage monitoring commands that would “wrap” around the executable portion of the script. By doing this, the software usage monitoring commands are executed when the script is initiated and also when the script ends.

---

**Note** - Using the shell script wrapper method may not be the best option if your command runs in the background. An end record is generated immediately after the command is executed and the time used is not accurate.

---

- Using the method of modifying the shell script executable command line, a single command line in the script starts the specified program, and also creates a begin and end software usage monitoring log entry.

The following procedures describe how to implement each software usage monitoring shell script method.

## ▼ How to Monitor Software Usage Using a Shell Script Wrapper

1. Using the editor of your choice, open the shell script to which you wish to add the software usage monitoring commands.
2. Before the program executable command line in the script, add the following `swu_rpt` command line.

```
swu_rpt -p product name [-I identifier] [-s server] [-a attr1=val1, attr2=val2,...] -b
```

In this command,

<code>-p product-name</code>	Indicates the name of the product that software usage is being recorded for; this option must always be included.
<code>-I identifier</code>	Specifies a unique, alpha numeric identifier for usage records; <code>swu_rpt</code> will provide its own identifier if one is not specified.
<code>-s server</code>	Specifies the server to which the usage records are to be sent. The default is the host aliased to <code>swusage_host</code> .
<code>-a attr1=val1, attr2=val2,...</code>	Allows the user to give the software usage entry unique or more descriptive information.
<code>-b</code>	Indicates that a begin entry should be recorded.

3. After the program executable in the script, add the following `swu_rpt` command.

```
swu_rpt -p product-name [-I identifier] [-s server] [-a attr1=val1, attr2=val2,...] -e
```

In this command,

<code>-p product-name</code>	Indicates the name of the product that software usage is being recorded for; this option must always be included.
<code>-I identifier</code>	Specifies a unique, numerical identifier for usage records; <code>swu_rpt</code> will provide its own identifier if one is not specified.
<code>-s server</code>	Specifies the server to which the usage records are to be sent. The default is the host aliased to <code>swusage_host</code> .
<code>-a attr1=val1, attr2=val2,...</code>	Allows the user to give the software usage entry unique or more descriptive information.
<code>-e</code>	Indicates that an end entry should be recorded.

#### 4. Exit the script, saving your changes. Verify that the script is executable.

### Example of Monitoring Software Usage Using a Shell Script Wrapper

The following example shows the software usage monitoring commands added to a shell script called `dir_script` that lists the directory in which it was called, the files in the directory, and the current date and time.

```
swu_rpt -p dir_script -I 295833 -s sherlock -a \
  ``Command1=pwd,Command2=ls,Options=-la,Command3=date`` -b
pwd
ls -la
date
swu_rpt -p dir_script -I 295833 -s sherlock -a \
  ``Command1=pwd,Command2=ls,Command3=date`` -e
```

In this example, two software usage report entries are created and look like the following.

Report Entry 1		Report Entry 2	
Type	Admin/Usage	Type	Admin/Usage
Product	dir_script	Product	dir_script
SubType	begin	SubType	end

Report Entry 1		Report Entry 2	
Time	8444845890	Time	8444845892
UserID	30581	UserID	30581
User	jod	User	jod
Host	buck	Host	buck
Domain	forest.field.com	Domain	forest.field.com
HostID	1234567890	HostID	1234567890
Locale	C	Locale	C
Version	1	Version	1
Usage Server	sherlock	Usage Server	sherlock
RecordID	295833	RecordID	295833
C_Command1	pwd	C_Command1	pwd
C_Command2	ls	C_Command2	ls
C_Options	-la	C_Command3	date
C_Command3	date		

## ▼ How to Add Software Usage Monitoring to a Shell Script Program Executable Command Line

1. Using the editor of your choice, open the shell script to which you wish to add the software usage monitoring commands.
2. Locate the command line in the script that calls the program.
3. Add the following arguments to the program executable command line.



```
swu_rpt -p product-name [-I identifier] [-s server] [-a attr1=val1, attr2=val2,...] -c command
```

In this command,

- p *product-name* Indicates the name of the product that software usage is being recorded for; this option must always be included.
- I *identifier* Specifies a unique, numerical identifier for usage records; *swu\_rpt* will provide its own identifier if one is not specified.
- s *server* Specifies the server to which the usage records are to be sent. The default is the host aliased to *swusage\_host*.
- a *attr1=val1, attr2=val2,...* Allows the user to give the software usage entry unique or more descriptive information.
- c *command* Specifies the program executable command.

#### 4. Exit the script, saving your changes. Verify that it is executable.

### Example of Adding Software Usage Monitoring to a Shell Script Program Executable Command Line

The following example shows the software usage monitoring command added to a program executable command line that executes FrameMaker.

```
swu_rpt -p Frame -I 295836 -s sherlock -a ``Command=maker,Version=4.0`` -c maker
```

In this example, the software usage report entry looks like this:

Report Entry 1		Report Entry 2	
Type	Admin/Usage	Type	Admin/Usage
Product	Frame	Product	Frame
SubType	Begin	SubType	End
Time	814824487	Time	8148244920

Report Entry 1		Report Entry 2	
UserID	30581	UserID	30581
User	jod	User	jod
Host	buck	Host	buck
Domain	forest.field.com	Domain	forest.field.com
HostID	1234567890	HostID	1234567890
Locale	C	Locale	C
Version	1	Version	1
Usage Server	sherlock	Usage Server	sherlock
RecordID	295836	RecordID	295836
C_Command	maker	C_Command	maker
C_Version	4.0	C_Version	4.0

## Using an Embedded Application

Software usage monitoring can be implemented by embedding calls to the `swu_rpt()` function into an application. This method works well for monitoring applications that you or others on your computer network have created.

For example, you may have created an online timecard to keep track of time spent on projects; however, you are not sure that it is being used by everyone. Within the online timecard application, you can embed calls to the `swu_rpt()` function, which then generates usage reports every time the application is executed.

The following procedure provides information about how to embed the software usage monitoring report function within an application.

### ▼ How to Embed Software Usage Monitoring into Applications

1. **Open the application source code file that will contain the software usage monitoring commands.**

2. Add the following header file to the application source code.

```
#include <swusage.h>
```

3. Add a `swu_rpt()` function specifying the begin of the application.

```
swu_rpt (``Server_name'', ``Identifier'', SWU_BEGIN, ``Product name'', avl)
```

4. Add a `swu_rpt()` function specifying the end of the application.

```
swu_rpt (``Server_name'', ``Identifier'', SWU_END, ``Product name'', avl)
```

5. Compile the application source code with one of the following arguments.

For static linking of the libraries:

```
$ ... -I/opt/SUNWswusg/include -L/opt/SUNWswusg/lib -Bstatic -lswusage -lnsl ...
```

For dynamic linking of the libraries:

```
$ ... -I/opt/SUNWswusg/include -R/opt/SUNWswusg/lib -L/opt/SUNWswusg/lib  
-lswusage -lnsl ...
```

## Example of Embedding Software Usage Monitoring into Applications

The following example shows an application that includes the software usage monitoring function.

```
#include <stdio.h> /* definition of NULL */  
#include <swusage.h> /* swu_rpt() prototype, swusage_alist definition */  
#define ATTRIBUTE_COUNT 3  
  
main()  
{  
    struct swusage_alist avl[ATTRIBUTE_COUNT];
```

(continued)

```

/*
 * Define some product specific attribute-value pairs that will
 * be included in the software usage report records.
 */
avl[0].u_attr = "ATTR_1";
avl[0].u_value = "val_1";
avl[1].u_attr = "ATTR_2";
avl[1].u_value = "val_2";

/*
 * Terminate the attribute list
 */
avl[2].u_attr = NULL;
avl[2].u_value = NULL;

/*
 * Create a begin record for the application
 */
swu_rpt(`Server_name`, `Identifier`, SWU_BEGIN, "My product name", avl);

/*
 * The application code would go here.
 */

/*
 * Create an end record for the application
 */
swu_rpt(`Server_name`, `Identifier`, SWU_END, "My product name", avl);
}

```

In this example, the software usage report entry looks like this:

Report Entry 1		Report Entry 2	
Type	Admin/Usage	Type	Admin/Usage
Product	My product name	Product	My product name
SubType	Begin	SubType	End
Time	8148244876	Time	8148244920
UserID	30581	UserID	30581
User	jod	User	jod

Report Entry 1		Report Entry 2	
Host	buck	Host	buck
Domain	forest.field.com	Domain	forest.field.com
HostID	1234567890	HostID	1234567890
Locale	C	Locale	C
Version	1	Version	1
Usage Server	Server_name	Usage Server	Server_name
RecordID	Identifier	RecordID	Identifier
C_ATTR_1	val_1	C_ATTR_1	val_1
C_ATTR_2	val_2	C_ATTR_2	val_2

## Transferring Software Usage Entries on a Client to the Master Log File on the Software Usage Monitoring Server

If software usage monitoring is installed on a client and software usage entries have been recorded on the client, you need to transfer the software usage report entries in the client's local queue to the master log file on the software usage monitoring server. Figure 13-3 provides an illustration of where the data is located.

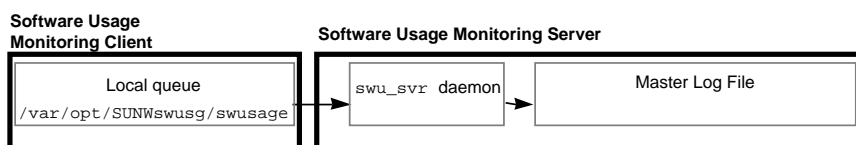

*Figure 13-3* Software Usage Monitoring Files and Locations

The software usage report entries in the local queue are located in the `/var/opt/SUNWswusg/swusage` directory. The report entries are designated by an

alphanumeric string. For example, if you entered the `ls` command in the local queue, you would see something like the following:

```
$ cd /var/opt/SUNWswusg/swusage
$ ls
swrepAAAa000Tv swrepAAAa000UL swrepBAAAa000Tv swrepBAAAa000UL
```

The software usage report entries are moved from this directory using the `swu_queue` command.

When the software usage monitoring system was installed, a `cron` job was added to the host's root `crontab`. This `cron` job runs the `swu_queue` command at a random time between midnight and 7 a.m. This `swu_queue` command transfers (flushes) the usage reports from the local queue to the master log file (`/var/opt/SUNWswusg/swusage.log`) on the software usage server specified in the usage entry.

Although this job runs automatically, there may be times when you wish to transfer the data in the local queue to the software usage monitoring server at a time other than when the `cron` job transfers the data. To do so, see "How to Transfer Software Usage Entries on the Client to the Master Log File on the Software Usage Monitoring Server" on page 247.

---

**Note** - When the `swu_queue` command is executed and the files are successfully transferred from the local queue to the master log file, the files are removed from the local queue; if the files do not get transferred (for example, the host specified in the entry was not running), the files in the local queue are not removed, which may cause your file system to fill. To prevent this from happening, you can disable the queue using the `swu_queue -d` command, which prevents usage records from being logged.

---

The following list explains what may happen when transferring software usage entries on the client to the master log file.

- If the `swu_svr` daemon is running on the host specified in the software usage entry, files will be transferred from the local queue to the master log file.
- If `swu_queue` can not connect to the software usage server daemon because the host in the record doesn't exist, the record is removed from the local queue.
- If `swu_queue` can communicate to the software usage server host, but there is no daemon running, then the record is removed.
- If the software usage server host specified in the usage record is not running or if there is an RPC failure, the usage record remains queued for later delivery.
- If the usage record doesn't contain a software usage server host, then the record is removed from the local queue.

## ▼ How to Transfer Software Usage Entries on the Client to the Master Log File on the Software Usage Monitoring Server

1. Log in to the client that has software usage report entries.
2. Become root.
3. Enter the `swu_queue` command.

```
# swu_queue -F
```

In this command,

<code>-F</code>	Transfers data in the local queue to the <code>swu_svr</code> daemon on the usage monitoring server.
-----------------	--

---

## Printing Software Usage Data from the Master Log File

After the software usage data has been moved from the local queue to the master log file on the host server, you may want to print the information in the master log file to another file, `stdout` (screen), or printer.

The software usage record entries are not formatted in the master log file. The `swu_print` command moves and formats the software usage report entries in the master log file to another file or the standard output device. Three options can be used with the `swu_print` command to format the entries differently.

The options available with the `swu_print` command are listed in Table 13-2, along with an example of how the software usage report entries are formatted with the associated option.

TABLE 13-2 swu\_print Options

Option	Format	Example				
-a	PRODUCT	SUBTYPE	TIME	RECORD_ID	USER	HOST
	maker	Begin	Feb 26	IDstring	jod	sherlock
	vi	Begin	17:08:17	IDstring	jad	holmes
			Feb 27			
			19:09:19			
-d	TYPE=Admin/Usage					
	Product=maker					
	SubType=Begin					
	Time=819653293					
	UserID=49740					
	User=jod					
	Host=buck					
	Domain=field.forest.com					
	HostID=55003efc					
	Locale=C					
	Version=1					
	Server=sherlock					
	RecordID=IDString					
-s	PRODUCT	TIME	USER	HOST		
	maker	01:31:47	jod	buck		
	vi	19:09:19	jad	doe		

Formatting these entries enables you to use `awk` or another search tool to search on keywords; formatting also enables you to easily translate the entries into another database or report.

**Note** - `swu_print` does not delete the software usage report entries from the master log file. In order to get rid of these entries, you must delete the master log file. Otherwise, entries are appended to the software usage report entries that you already copied out using the `swu_print` command. This could result in your file system becoming full; see “How to Remove the Master Log File” on page 251 for information about how to safely remove this file.



The report entries created by the software usage monitoring system vary depending upon the command used to generate the entry; however, all entries have some fields that will always appear. Table 13-3 provides a list of all possible report entries, along with a description of each entry, and a list of when the entry is used.

**TABLE 13-3** Report Entries

<b>Field</b>	<b>Possible Entries</b>	<b>Description</b>	<b>When Used</b>
Type	Admin/Usage	Indicates the record is a system administration, software usage entry.	Always
Product	Varies	Indicates the product name (or program name) of the software that is being logged; specified with the <code>swu_rpt</code> command or function.	Always
User	Varies	Indicates the user who ran the software. The entry will indicate the user's login name.	Always
SubType	Begin	Intended to indicate that the software associated with this record has begun execution at the indicated time.	<code>swu_rpt</code> command options <code>-b</code> or <code>-c</code>
	End	Intended to Indicate that the software associated with this record has ended execution at the indicated time.	<code>swu_rpt</code> command options <code>-e</code> or <code>-c</code>
	Install	Intended to indicate that the software associated with this record has been installed.	<code>swu_rpt</code> command <code>-i</code> option
	Enable Queue	Indicates that the local <code>swu_queue</code> has been enabled.	<code>swu_queue</code> command <code>-e</code> option
	Disable Queue	Indicates that the local <code>swu_queue</code> has been disabled.	<code>swu_queue</code> command <code>-d</code> option
Time	Varies	Indicates the time the software began execution, ended execution, or was installed. The value indicates the value of time in seconds since 00:00:00 UTC January 1, 1970.	Always
UserID	Varies	Indicates the user ID of the user who ran the software.	Always
Host	Varies	Indicates the name of the workstation or server that the program or command was run on.	Always

TABLE 13-3 Report Entries (continued)

Field	Possible Entries	Description	When Used
Domain	Varies	Indicates the name service domain that the host resides in.	Always
HostID	Varies	Indicates the hardware serial number of the host workstation or server.	Always
Locale	Varies	Indicates the current value of the LANG environment variable.	Always
Version	Varies	Indicates the software usage monitoring version (specified by the software usage monitoring program).	Always
Usage Server	Varies	Indicates the software usage server to which usage entries are to be sent.	Always
RecordID	Varies	Indicates a unique, numerical ID that is specified with the swu_rpt command; if no identifier is specified, the parent process ID process and time is used as the default.	Always

---

**Note** - If the field variable is not set, ?? would be the entry for the field variable because software usage monitoring could not determine its value.

---

To copy and format the software usage monitoring report entries in the master log file to another file or the standard output device, you need to perform the following procedure.

## ▼ How to Print Software Usage Data from the Master Log File

1. Log in to the software usage monitoring host server.
2. Open a command tool and enter the `swu_print` command.

```
$ swu_print [-a|-d|-s] [-f filename] [-l log_file]
```

In this command,

<code>-a</code>	Specifies the format <code>swu_print</code> is to use (default - all). Refer to Table 13-2 for format examples.
<code>-d</code>	Specifies the format <code>swu_print</code> is to use (dump). Refer to Table 13-2 for format examples.
<code>-s</code>	Specifies the format <code>swu_print</code> is to use (summary). Refer to Table 13-2 for format examples.
<code>-f filename</code>	Specifies the file to which information in the log file will be directed.
<code>-l log_file</code>	Specifies the master log file. If this option is not specified, the default file <code>/opt/SUNWswusg/swusage.log</code> is used.

---

## Removing the Master Log File

To keep your file system from filling up, you will periodically have to clean up the master log file; however, you must follow a certain procedure to properly remove this log file to prevent future data loss.

The following procedure describes how to safely remove the master log file.

### ▼ How to Remove the Master Log File

1. **Log in as root on the software usage monitoring server.**
2. **Move the master log file to a temporary log file.**

```
# mv /var/opt/SUNWswusg/swusage.log /tmp/tmp.log
```

3. **Perform any processing you wish to** `/tmp/tmp.log`.
4. **Remove** `/tmp/tmp.log`.

```
# rm /tmp/tmp.log
```

5. **Log out.**

---

**Note** - This procedure moves all the software usage record entries located in `swusage.log` to a new file; any new records generated during this procedure will cause a new `swusage.log` file to be created.

---

# Glossary

---

<b>aliases file</b>	A file containing mail aliases, which are names that represent distribution lists of users.
<b>authentication</b>	A function provided by the <code>sadmin</code> daemon which verifies the identity of the user making a system administration request across the network.
<b>authorization</b>	The <code>sadmin</code> daemon verifies that the authenticated user has permission to execute the Solstice AdminSuite software on the server. After the user identity is verified, the <code>sadmin</code> daemon uses the user identity to perform authorization checks.
<b>AutoClient system</b>	A system with a monitor and keyboard, CPU and memory, Ethernet hardware, and a small disk (at least 100-Mbyte) to cache its root (/) and /usr file systems from a server on a network. This system gets its other file resources from a server on the network.
<b>auto_home (or auto.home) file</b>	An indirect automounter map that contains entries enabling client systems to mount their home directories automatically. It is primarily accessed using User Manager.
<b>baud rate</b>	The switching speed of a line, which is the number of changes in the electrical state of the line per second. At low speeds, baud rate is equivalent to bits transmitted per second. At higher speeds, the bits transmitted per second is greater than the baud rate because one baud can be made to represent more than one bit.
<b>Berkeley Software Distribution (BSD)</b>	One of two major “flavors” of the UNIX® operating system, the other being System V. SunOS operating system releases before SunOS 5.0 (Solaris 2.0) are BSD.
<b>boot server</b>	A system that provides the programs and information a client needs to boot.

<b>bootparams file</b>	A file containing entries that are used to enable client systems to boot from the network.
<b>chapter</b>	A chapter represents the properties of an object. You can view and/or change the properties within a chapter by opening it.
<b>content type</b>	Specified when you add support for a local printer. Identifies the particular formats of files that can be printed. Supported content types are: PS (PostScript), ASCII, simple, or any.
<b>context</b>	A context describes the environment or components of the object whose properties you are going to view and/or edit. In the case of File System Manager, the context includes what name service to modify or how to view and modify the file systems on a server. In the case of Disk Manager, the context includes the disk metaset to modify if you have the Solstice DiskSuite 4.0 software installed on the system.
<b>context type</b>	A field in the Storage Manager Load Context window that indicates the name of the tool with which the current context is associated.
<b>current context</b>	A field in the Storage Manager Load Context window that specifies the host name with which the current context is associated.
<b>Database Manager</b>	One of Solstice AdminSuite's applications used to manage network-related system files such as <code>aliases</code> and <code>netmasks</code> .
<b>dataless client</b>	A system with a monitor and keyboard, CPU and memory, Ethernet hardware, and small local disk for the swap area and the root ( <code>/</code> ) file system. This system gets its other file resources from a server on the network.
<b>default</b>	An assumed value, or an action taken automatically unless you specify otherwise.
<b>device</b>	A hardware component, such as a printer or disk drive, acting as a unit to perform a specific function.
<b>diskless client</b>	A system with a monitor and keyboard, CPU and memory, and Ethernet hardware. This system gets its file resources and swap space from a server on a network.
<b>Ethernet address</b>	A system's hardware address. The Ethernet address can be displayed using the <code>banner</code> command from the PROM level.

<b>ethers file</b>	A file containing Ethernet addresses of network client systems.
<b>fdisk partition</b>	A logical partition of a disk drive dedicated to a particular operating system on x86 systems.
<b>file server</b>	A system that shares file resources and disk storage space for network clients.
<b>file system</b>	A hierarchy of files and directories in the Solaris operating environment.
<b>generic system</b>	A system that is not running the Solaris software, or whose type has not yet been updated using Host Manager's Update System Type feature, or uses local or loghost entries in the system management databases.
<b>group</b>	A collection of users who share files and other system resources. Each user belongs to a primary group (listed in the user's <code>passwd</code> entry), and optionally, one or more secondary groups.
<b>group file</b>	A file containing entries for UNIX groups. The <code>group</code> file is accessed from Group Manager.
<b>group ID (GID)</b>	A group identification number used by the system to identify a user's primary group. Group ID numbers for users usually range from 100 to 60000.
<b>Group Manager</b>	One of Solstice AdminSuite's applications used to manage group information in the <code>group</code> file.
<b>hardwired</b>	Refers to a device such as a terminal that is physically connected to the local system.
<b>Host Manager</b>	One of Solstice AdminSuite's applications used to manage network client services.
<b>host name</b>	A unique name that identifies a system.
<b>initialization files</b>	Special files that run automatically when you log in. When an account is created and you specified a skeleton path, User Manager copies generic versions of the initialization files into the user's home directory. You can then edit the copies as needed to customize each user's environment.

<b>install server</b>	A system on the network that provides a Solaris CD image (either from a CD-ROM drive or a copy on hard disk) for other systems to install from.
<b>IP address</b>	A system's unique network address.
<b>JavaStation</b>	A system with a monitor and keyboard, CPU and memory, and Ethernet hardware. This system gets its file resources and swap space from a server on a network and is used to run Java applications.
<b>launcher</b>	See Solstice Launcher.
<b>local printer</b>	A printer physically connected to the local system.
<b>locale file</b>	A file containing the default locales used by network clients.
<b>media server</b>	A system that shares a CD-ROM device for remote installation of software.
<b>metaset</b>	A logical grouping of disks.
<b>modem</b>	A data communication device that translates, or <i>modulates</i> , digital information into an analog signal that can be transmitted via phone lines.

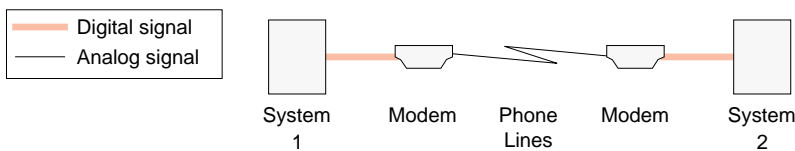

<b>name service</b>	<p>Method by which system information is maintained in the network. There are three selections in Solstice AdminSuite: NIS, NIS+, and None.</p> <ul style="list-style-type: none"> <li>■ NIS – Name service shipped with the SunOS 4.1.x operating system (Solaris 1). Designated systems, called NIS servers, contain maps that store information about the network, its clients, and its users.</li> <li>■ NIS+ – Name service shipped with the Solaris software. Making use of true databases (instead of two-column maps that simply associate one variable with another), NIS+ stores more information than NIS.</li> <li>■ None – Method for administrators of networks that do not use a network name service; administrators usually select one system</li> </ul>
---------------------	---



on the network on which to maintain a master copy of the /etc configuration files.

<b>name service domain</b>	A group of systems and the information served to those systems.
<b>netgroup file</b>	A file containing entries for <i>netgroups</i> , a group of systems granted identical access to network resources for security and organizational reasons.
<b>netmasks file</b>	A file containing network mask values used to implement IP subnetting.
<b>network client</b>	A system that uses remote resources from a server.
<b>networks file</b>	A file containing information about available networks.
<b>nsswitch.conf</b>	A file that contains an entry for each system file and a corresponding name service source to search for the system file information. The name service sources are designated as keywords— <i>nis</i> , <i>nisplus</i> , or <i>files</i> . If more than one name service source is listed, they are searched in the order given.
<b>object</b>	A disk or file system, whose properties you can view and modify.
<b>OpenWindows</b>	A windowing system based on the OPEN LOOK® graphical user interface.
<b>OS server</b>	A server that provides OS services to support diskless clients, dataless clients, and AutoClient systems.
<b>OS services</b>	OS software that you can add to an OS server for it to support clients of other platform groups and Solaris releases. You can also add services for clients that are the same platform group and require the same Solaris release as the OS server.
<b>parallel port</b>	A port that transfers one or more bytes simultaneously over multiple lines. See also serial port.
<b>partition</b>	See slice.
<b>passwd file</b>	A file that contains user account information such as user name, user ID, group ID, and home directory. User Manager accesses this file.

<b>password status</b>	<p>Characteristics associated with a user's password. User Manager's Add User window has a password status menu that enables you to control user password characteristics. The choices are:</p> <ul style="list-style-type: none"> <li>■ Normal password – Sets a password for the user.</li> <li>■ Cleared until first login – Prompts user for a password on first login.</li> <li>■ Account is locked – Disables account. Account can be unlocked by assigning a new password. This type of account allows a user to own files but not log in.</li> <li>■ No password—setuid only – Disables the ability to directly log in to the account. This allows programs such as <code>lp</code> or <code>uucp</code> to run under an account, without allowing a user to log in.</li> </ul>
<b>permissions</b>	A set of attributes that determines which users have access to read, write, and execute a file or directory's contents.
<b>port</b>	A channel through which a device communicates with the operating system.
<b>port monitor</b>	<p>A program that continuously “watches out” for requests to log in, or requests to access printers or files.</p> <p>When a port monitor detects a request, it sets the parameters required to establish communication between the operating system and the device requesting service. Then the port monitor transfers control to other processes that provide the services needed.</p>
<b>primary group</b>	<p>A user's default group, which determines the group ownership on a file the user creates, or is allowed to access, if already created. Membership in this group is defined by the group identifier listed in the user's entry in the <code>passwd</code> file.</p>
<b>print client</b>	A system that uses a print server for printing files.
<b>print server</b>	A system that has a printer physically connected to it and the appropriate software configured to print both local and remote print requests.
<b>Printer Manager</b>	One of the Solstice AdminSuite's applications used to manage local and remote printer setup.
<b>printer name</b>	A unique name, with a maximum of 14 characters, for a printer.

<b>printer type</b>	The <code>terminfo</code> database entry that contains the control sequences that initialize the printer.
<b>profile server</b>	A system that contains JumpStart files for systems to perform a custom JumpStart installation.
<b>PROM</b>	A programmable read-only memory chip with a program called the monitor that runs a quick self-test procedure and checks such things as the hardware and memory on the system. If no errors are found, the system begins the automatic boot process.
<b>PROM prompt</b>	The prompt displayed when the system halts; either <code>&gt;</code> or <code>ok</code> .
<b>property book</b>	The mechanism by which you identify, view, and modify the properties of editable objects.
<b>property browser</b>	A property browser is like the table of contents in a book. It lists all the chapters and subchapters in a book. This allows you to quickly navigate to the desired chapter whose properties you want to view or modify.
<b>property viewer</b>	Displays the object or context properties you can view or modify.
<b>protocols file</b>	A file containing information about Internet protocols used in your network.
<b>remote printer</b>	A printer connected to a remote system such as a print server.
<b>root</b>	A user who has access to all parts of the system. This is usually the system administrator. Also known as superuser.
<b>rpc file</b>	A file containing entries for available Remote Procedure Call (RPC) services (by name) and their associated program numbers and aliases.
<b>sadmind daemon</b>	A distributed system administration daemon that carries out security tasks when administrative tasks are performed across the network.
<b>secondary group</b>	Membership in this group is defined by the group identifier listed in the <code>group</code> file with a list of users as members.
<b>serial port</b>	A port which transmits a byte of information bit-by-bit over a single line using a standard communications protocol such as RS-423. See also parallel port.

<b>Serial Port Manager</b>	One of the Solstice AdminSuite's applications used to manage serial devices.
<b>services file</b>	A file containing information about network services and their "well-known" port numbers.
<b>shadow file</b>	A file containing encrypted user passwords and password aging information. Accessed using User Manager.
<b>shell</b>	A command-line interpreter program that accepts and executes commands that you type. There are several varieties of shell programs, and three are included in the Solaris software: Bourne, Korn, and C.
<b>skeleton path</b>	A prototype directory containing start up files. See also initialization files.
<b>slice</b>	A slice is an area on a disk composed of a single range of contiguous blocks. A slice is a physical subset of a disk (except for slice 2, which by convention represents the entire disk). Before you can create a file system on a disk, you must format it into slices.
<b>Solstice AdminSuite</b>	A graphical user interface used to perform administrative tasks such as managing users, groups, hosts, printers, file systems, disks, and serial devices.
<b>Solstice Launcher</b>	The base window of the interface, used to start the other application tools.
<b>standalone system</b>	A system with a monitor and keyboard, CPU and memory, approximately 200 or more megabytes of disk space, and usually a backup device. It may or may not be connected to a network.
<b>superuser</b>	A user who has access to all parts of the system. This is usually the system administrator. Also known as root.
<b>sysadmin group</b>	The UNIX group whose members belong to the sysadmin group (Group 14). Members of the sysadmin group can use Solstice AdminSuite's applications locally or remotely.
<b>system default (printer)</b>	The printer your print requests will be sent to if you do not specify a printer.
<b>system files</b>	Files that contain important system administration information such as user accounts, passwords, and groups. These files are contained

on the local system in the `/etc` directory, or in the NIS or NIS+ database on a name server.

<b>System V</b>	One of two major “flavors” of the UNIX operating system, the other being BSD. The SunOS 5.0 operating system (Solaris 2.0) and subsequent releases are System V.  An input/output device that usually has a keyboard for input and a video screen or printer for output. Terminal, however, is often used as a shorthand for <i>alphanumeric terminal</i> , which is a serial port device capable of displaying only letters, numbers, and other characters such as those produced by a typewriter.
<b>timezone file</b>	A file containing entries for systems and their geographic region and time zone.
<b>user account</b>	A record of essential user information stored on the system. You must have a user account to access a system.
<b>user ID (UID)</b>	A number used by the operating system to identify a user. User ID numbers for users usually range from 100 to 60000.
<b>user name</b>	The name, assigned to an individual user, that controls access to a system.
<b>User Manager</b>	One of the Solstice AdminSuite’s applications used to manage user account information.
<b>utmp entry</b>	A entry made in the <code>/var/adm/utmp</code> file when a user logs in and out of the system.
<b>workspace</b>	The background screen area on which windows and icons are displayed.
<b>ybind</b>	An NIS daemon process that runs on all client systems and allows the client to communicate with an NIS server.
<b>zsmn</b>	Sun’s naming convention for the port monitor that monitors a system’s two serial ports. It is derived from the Zilog serial communications driver.



# Index

---

## A

### access

#### to printers

adding, 160

deleting, 165

Add Access to Printer window, 159, 161

Add Application window, 37

Add option (Edit menu)

Group Manager, 120

Host Manager, 84

User Manager, 124

Add window

Database Manager, 172

Host Manager, 84 to 86, 99, 102, 105, 108,  
110

User Manager, 124

adding

access to a printer, 160

applications

in global register, 33, 35

in local register, 32

client support, 73

groups, 120

JavaStation Client, 105

modems, 144

multihomed host, 110

server support, 73

Solaris 2.x OS services to OS servers, 95

standalone system information, 95

SunOS 4.x services to OS servers, 90

support

for dataless clients, 106, 109

for diskless clients, 100, 104

for OS servers, 83

for standalone systems, 83

system file entry, 172

terminals, 143

user accounts, 124

Admin Help, 46

buttons, 47

AdminSuite, , *see* Solstice AdminSuite,

aliases file, 170

Application Path Selection window, 40

Application Properties window, 39

application properties, customizing, 37

application tools

filtering entries, 48

general reference, 45, 54

applications

customizing, locally registered, 39, 40

registering in Solstice Launcher, 31, 36

removing

from global registry, 34, 36

from local registry, 32

architecture type

for dataless clients, 106

for diskless clients, 100

for standalone systems, 85

selecting when adding Solaris 4.x OS  
services, 92

ASCII terminal, 9

authentication security, 17

levels of, 18

authorizing permissions, 17

AutoClient systems  
  characteristics, 65  
auto\_home file, 117

## B

baud rate for modems, 146  
bit-mapped display monitor, 8  
boot servers  
  defined, 70  
  for dataless clients, 107  
  for OS servers, 85  
  for standalone systems, 85  
boot software, 64  
boot subsystems  
  secondary boot subsystem  
    x86, 221  
booting  
  dataless clients, 107  
  diskless clients, 101  
  subsystems on an x86, 221  
bootparams file, 73, 170  
buttons (Solstice AdminSuite), 50

## C

CD image, , *see* Solaris CD image,  
changing, , *see* modifying,  
clients, 100  
  defined, 62  
  support for, 61, 112  
    maintaining, 110, 112  
commands  
  filtering, 49, 51  
  install4.x, 92  
  software usage monitoring, 227, 244  
  soladdapp, 31, 33 to 36  
  swu\_print, 247, 248, 250  
configuration information for diskless  
  clients, 101  
configuring  
  modems, 146  
  ports, 144 to 146  
context  
  definition, 178  
conventions, typographic, xiv

Convert to OS Server option (Host Manager  
  Edit menu), 88

Convert window (Host Manager), 89  
converting standalone systems, 88  
Copy option (User Manager Edit menu), 127  
copying user accounts, 127  
credentials for security levels, 18  
cron job  
  software usage monitoring, 229  
customizing  
  locally registered applications, 39, 40  
  Solstice Launcher, 37, 38

## D

daemons  
  sadmind, 17  
Database Manager  
  Add window, 172  
  advanced uses, 169  
  files modified by, 170  
  main window, 172  
  Modify window, 173  
  starting, 172  
dataless clients, 65  
  adding services for, 90  
  adding support for, 105  
  booting, 107  
  compared to other systems, 63  
  operating system services for, 64, 68  
default printer, setting  
  with Printer Manager, 156, 157  
defaults  
  for adding system support, 83  
  for user accounts, 123  
Delete option (Edit menu)  
  Group Manager, 131  
  User Manager, 133  
deleting  
  access to printers, 165  
  groups, 131  
  port services, 148  
  printers from print servers  
    for NIS or NIS+, 165  
    if no name service, 166  
  support for a system, 111  
  system file entry, 174



- user accounts, 133
- user home directories, 133
- user mailboxes, 133
- disabling ports, 148
- Disk Manager
  - batch editing, 202
  - batching, 202
  - description, 200
  - main window, 200
  - property book, 202
  - selecting multiple disks, 202
- diskless clients, 65
  - adding support for, 90, 100
  - booting, 101
  - compared to other systems, 63
  - operating system services for, 64, 68
- diskset
  - definition, 178

## E

- Edit menu
  - Database Manager
    - Add option, 172
    - Delete option, 174
    - Modify option, 173
  - Group Manager
    - Add option, 120
    - Delete option, 131
    - Modify option, 129
  - Host Manager
    - Add option, 84, 100, 104, 106, 109
    - Modify option, 95, 97, 111, 129
    - Set Defaults option, 83
  - Printer Manager
    - Add Access to Printer option, 159, 161
    - Delete option, 166, 167
    - Install Printer option, 156
    - Modify option, 163
  - Serial Port Manager
    - Delete option, 149
    - Modify option, 144, 145, 147
    - Modify Service option, 146

- User Manager
  - Add option, 124
  - Copy option, 127
  - Delete option, 133
  - Modify option, 131
  - Set Defaults option, 123
- /etc files
  - as source of name service information, 19, 74, 78, 116, 152
- /etc/lp directory
  - when printer is added in, 157, 166, 167
- /etc/printers.conf file
  - of print server, 157, 166, 167
- /etc/syslog.conf file, 54
- /etc/saf/pmtag/\_pmtab file, 142
- /etc/saf/\_sactab file, 142
- ethers file, 170
- example of, 105, 110
- /export file systems, 64

## F

- Federated Naming Service, used with NIS+, 154
- field replaceable unit (FRU), 66
- File menu
  - Host Manager
    - Save Changes option, 101
    - Update System Types option, 83
- File Selection window, 40
- file servers
  - for dataless clients, 106
  - for diskless clients, 100, 104
- File System Manager
  - description, 182
  - main window, 182
  - property book, 184
- Filter Group menu, 48
- filtering commands, 49, 51
- finding a printer entry, 167
- footer information, 53

## G

- global browsing, 51
- global registry, 31
- global security policy, 20

- group 14, 18
  - membership required in, 9
  - permissions granted to, 18
- group file, 118
- group ID, 120
- Group Manager
  - Add window, 120
  - adding users in sysadmin group, 15
  - defined, 116
  - Delete option (Edit menu), 131
  - files modified by, 116
  - main window, 120
  - Modify option (Edit menu), 129
  - Modify window, 130
  - prerequisites for using, 119
  - starting, 119, 120
  - tasks
    - for maintaining user accounts, 128
    - for setting up user accounts, 118
- groups
  - adding, 120
  - changing name of, 129
  - deleting, 131
  - modifying, 129
  - naming, 120

## H

- Help utility, 46
- Hide list, moving applications to or from, 37
- host
  - software usage monitoring, 230
- Host Manager, 61, 112
  - Add window, 85, 86, 99, 102, 105, 108, 110
  - Convert window, 89
  - Delete option (Edit menu), 111
  - files modified by, 73
  - global browsing, 51
  - limitations of, 71
  - main window, 53, 82
  - Modify window, 96, 111
  - progress indicators, 53
  - Set Add Defaults window, 83
  - Set Defaults option (Edit menu), 83
  - starting, 81
  - status indicators, 53

- tasks
  - available in, 66, 67
  - for adding server/client support, 79, 80
  - for maintaining server/client support, 110
  - Update System Types menu, 83
  - Update System Types option (File menu), 83
- hosts file, 73, 170

## I

- icons
  - path name, 40
  - tool, 38
- initializing ports, 147
- Install main menu, 92
- Install Printer window, 156
- install servers
  - defined, 70
  - for adding Solaris 2.x OS services, 95
  - for dataless clients, 106
  - selecting, 84
- install4x command, 92, 94
- installation services, 62
- installing printer, 156

## J

- JavaStation
  - defined, 65
- JumpStart installation, 64, 70

## K

- keyword files, 19

## L

- local queue
  - software usage monitoring, 229
- local security policy, 20
- locale file, 170
- locally registered applications,
  - customizing, 39, 40
- logging
  - Host Manager operations, 54

## M

- mailboxes (user), deleting contents of, 133
- main window, 45
- maintaining
  - client support, 110, 112
  - server support, 110, 112
- managing
  - client support, 61, 112
  - modems, 137, 149
  - network service files, 169, 175
  - server support, 61, 112
  - terminals, 137, 149
  - user accounts, 115, 134
- master log file
  - removing, 251
- MDB floppy, 223
- Members List
  - creating for a group, 120
  - for sysadmin group, 16
- menu bars, 46
- mixed-mode, 74
- modems
  - adding, 144
  - configuring, 146
  - managing, 137, 149
- Modify option (Edit menu)
  - Database Manager, 173
  - Group Manager, 129
  - Host Manager, 95, 97, 111, 129
  - Serial Port Manager, 144, 145
  - User Manager, 131
- modify permissions for NIS+ tables, 14
- Modify Service option (Serial Port Manager Edit menu), 146
- Modify Service window (Serial Port Manager), 146
- Modify window
  - Database Manager, 173
  - Group Manager, 130
  - Host Manager, 96, 111
  - Printer Manager, 163
  - Serial Port Manager, 144, 145, 147
  - User Manager, 131, 132
- modifying
  - group name, 129
  - groups, 129
  - locally registered application, 39

- printer configuration information, 163
- support for systems, 111
- system file entry, 173
- user accounts, 131

- Module Selection menu, 93
- monitor, requirements for, 8
- multihomed host
  - defined, 71
- multiple device boot (MDB) floppy, 223

## N

- name service, 12
  - information used by sadmind daemon, 19
  - selecting a, 13
  - setting up a policy, 74
- netgroup file, 170
- netmasks file, 170
- network service files, managing, 169, 175
- network services, 62
- networks file, 170
- NIS
  - access privileges required for, 9, 154
  - keyword, 19
  - not available for Serial Port Manager, 13
  - setting up access for, 21
  - using with Solstice AdminSuite, 12
  - when printer is added in, 156, 157, 161
  - when printer is deleted from, 166
- NIS+
  - access privileges required for, 9, 154
  - admin group, membership in, 154
  - keyword, 19
  - not available for Serial Port Manager, 13
  - permissions, modifying, 14
  - permissions, setting up, 20
  - security for, 19
  - using with Solstice AdminSuite, 12
  - when printer is added in, 156, 157, 161
  - when printer is deleted from, 166
- None
  - printer added in client's /etc files, 162
  - printer added in server's /etc files, 156, 157
  - printer deleted from client's /etc files, 166
  - printer deleted from server's /etc files, 167

## O

- object
  - definition, 178
- OpenWindows, 7, 9
- operating system services, 62, 68
- /opt directory, 64
- OS servers
  - adding
    - SunOS 4.x OS services to, 90
  - adding support for, 83
  - converting standalone systems to, 88
- OS Services window, 88

## P

- parity for modems, 146
- passwd file, 118
- permissions
  - authorization of, 17
  - for NIS+ management, 20
  - for NIS+ tables, 14
- policy\_defaults, 55
- port services, deleting, 148
- ports
  - configuring, 144 to 146
  - disabling, 148
  - initializing, 147
- print clients, access to printers, 161
- print servers
  - managing, 153
  - setting up, 156
- printer
  - adding access to, 160
  - deleting access to, 165
  - installing, 156
  - modifying configuration for, 163
- printer configuration information,
  - modifying, 163
- Printer Manager
  - Add Access to Printer window, 159, 161
  - files modified by, 152
  - Install Printer window, 156
  - Load window, 155
  - main window, 155
  - Modify window, 163
  - starting, 154
- printing
  - software usage entries, 250

- profile servers
  - defined, 70
  - for dataless clients, 107
  - for OS servers, 85
  - for standalone systems, 85
- progress indicators, 53
- prompts in command examples, xv
- property book
  - definition, 178
- protocols file, 171

## R

- registering applications in Solstice Launcher, 31, 36
- registry
  - global, 31
    - adding applications in, 35
    - removing applications from, 36
  - local
    - adding applications in, 33, 34
    - removing applications from, 34
  - private
    - adding applications in, 31
    - removing applications from, 32
- remote booting, 62
- remote installation, 70
  - not available for SunOS 4.x, 71
- removing applications
  - from global registry, 34, 36
  - from local registry, 32
- report entries
  - explained, 249, 250
- report entry
  - software usage monitoring in a local queue, 229
- requirements
  - for using AdminSuite, 8
  - for using NIS map information, 15
  - for using NIS+ table information, 14
- .rhosts file, entry required for NIS, 15
- root file system
  - for dataless clients, 65
  - for diskless clients, 65
  - for servers, 64
  - for standalone systems, 64
- root password, creating for diskless clients, 102

- root path
  - specifying for diskless clients, 100, 104
- root privilege, 9
  - security for, 18
  - using sysadmin group privileges
    - instead, 155
- root .rhosts file, 15
- rpc file, 171

## S

- sadmind daemon, 17
  - name service information used by, 19
- scripts
  - default scripts, 59
  - directory, 58
  - environment variables, 59
  - using with User Manager or Host Manager, 58
- secondary boot subsystem
  - x86, 221
- security, 17, 21
  - levels of, 18, 19
    - changing, 19
  - policy, 20, 21
- selecting a name service, 13
- sequence of events
  - software usage monitoring
    - in a shared file system environment, 230
  - software usage monitoring in a client server environment, 228
- Serial Port Manager
  - description of, 138
  - main window, 143
  - Modify Service window, 146
  - Modify window, 144, 145, 147
  - starting, 142
  - Template menu, 144
- servers, 61, 112
  - boot, 70
  - compared to other systems, 63
  - defined, 62
  - file systems of, 64
  - install, 70
  - profile, 70
  - software to support other systems, 64

- support for, 61, 112
  - maintaining, 110, 112
- services file, 171
- Set Add Defaults window
  - Host Manager, 83
  - User Manager, 123
- Set Defaults option (Edit menu)
  - Host Manager, 83
  - User Manager, 123
- shadow file, 118
- Show list, moving applications to or from, 37
- software usage entries
  - generating using a command line interface, 234
  - generating using a shell script executable command line, 237
  - generating using a shell script wrapper, 237
  - generating using shell scripts, 237
- software usage monitoring
  - commands, 227, 244
  - cron job, 246
  - definition, 226
  - in a client/server environment
    - sequence of events, 228
  - in a shared file system environment, 230
  - printing entries, 247
  - removing the master log file, 251
  - report entries, 249, 250
  - transferring software usage entries on a client, 245
  - using an embedded application, 242
  - verifying installation, 231 to 233
- soladdapp command, 31
  - globally registering applications with, 33, 35
  - removing globally registered applications with, 34, 36
- Solaris 2.x OS services, adding to OS servers, 95
- Solaris CD image, 64

- setting path
  - for dataless clients, 106
  - for OS servers, 84
  - for standalone systems, 84
  - when adding Solaris 2.x OS services, 95
  - when converting standalone to OS server, 88
- Solaris OS server, 68
- Solstice AdminSuite
  - application tools, 45, 54
  - benefits of using, 5
  - buttons, 50
  - description of, 3
  - Help utility, 46
  - knowledge required to use, xiii
  - launcher, 7
  - main windows, 45
  - menu bars, 46
  - NIS+ environment, 14, 17
  - prerequisites for running, 8
  - security, 17, 21
    - levels of, 18, 19
    - policy, 20, 21
  - starting, 7
  - tasks available in, 4
- Solstice Launcher, 7, 29, 40
  - customizing, 37, 38
  - menus, 30, 48
  - registering applications in, 31, 36
  - starting, 29
- SPARC
  - booting, 213
- standalone systems
  - adding support for, 83
  - compared to other systems, 63
  - converting to OS servers, 88
  - networked, 64
- starting
  - Database Manager, 172
  - Group Manager, 119, 120
  - Host Manager, 81
  - Printer Manager, 154
  - Serial Port Manager, 142
  - Solstice AdminSuite, 7
  - Solstice Launcher, 29
  - User Manager, 122
- status indicators, 53
- Storage Manager, 178
  - context
    - definition, 178
  - Disk Manager
    - description, 200
  - File System Manager
    - description, 182
  - Load Context Property Book, 178, 181
  - object
    - definition, 178
  - property book
    - definition, 178
- SunOS 4.x OS services, 71
  - adding, 90
- support for systems
  - adding
    - for dataless clients, 105
    - for diskless clients, 100
    - for OS servers, 83
    - for standalone systems, 83
  - defined, 62
  - deleting, 111
  - modifying, 111
  - setting defaults, 83
- swap path for diskless clients, 100
- swap size for diskless clients, 100
- swap space, 64
  - for dataless clients, 65
- swu\_print
  - command, 230
  - options, 248, 250
- swu\_rpt
  - command
    - function, 229
- swu\_svr command
  - software usage monitoring, 229
- swu\_svr daemon
  - software usage monitoring, 229
  - starting and stopping, 233
- sysadmin group
  - adding users
    - in name service, 19
  - membership required in, 9, 14
  - permissions granted to, 18
- system file entry
  - adding, 172
  - deleting, 174

- modifying, 173
- system information
  - adding, 84
  - specifying for diskless clients, 100, 104
- system types, 62, 67
  - AutoClient, 65
- updating, 83

## T

- Template menu (Serial Port Manager), 144
- terminals
  - adding, 143
  - managing, 137, 149
  - template, 141
- /tftpboot directory, 74
- timezone file, 73, 171
- tool icons, customizing, 38
- typographic conventions, xiv

## U

- Update System Types option (Host Manager File menu), 67, 83
- updating system types, 83
- user accounts, 115, 134
  - adding, 124
  - copying, 127
  - deleting, 133
  - maintaining, 128, 134
  - managing, 115, 134
  - modifying, 131
  - setting defaults for, 123

- user home directories, deleting, 133
- user mailboxes, deleting, 133
- User Manager
  - Add option (Edit menu), 124
  - Add window, 124
  - Copy option (Edit menu), 127
  - defined, 116
  - Delete option (Edit menu), 133
  - Edit menu
    - Delete option, 133
    - Modify option, 131
  - files modified by, 117
  - main window, 123
  - Modify window, 131, 132
  - prerequisites for using, 122
  - Set Add Defaults window, 123
  - Set Defaults option (Edit menu), 123
  - starting, 122
- /usr file system, 64

## V

- /var/saf/ file, 142
- Volume Management, 91, 92
  - and CD image software, 95, 98

## X

- x86 booting subsystems, 221

## Y

- ypbind, running with -broadcast option, 15